

50/60 Hz

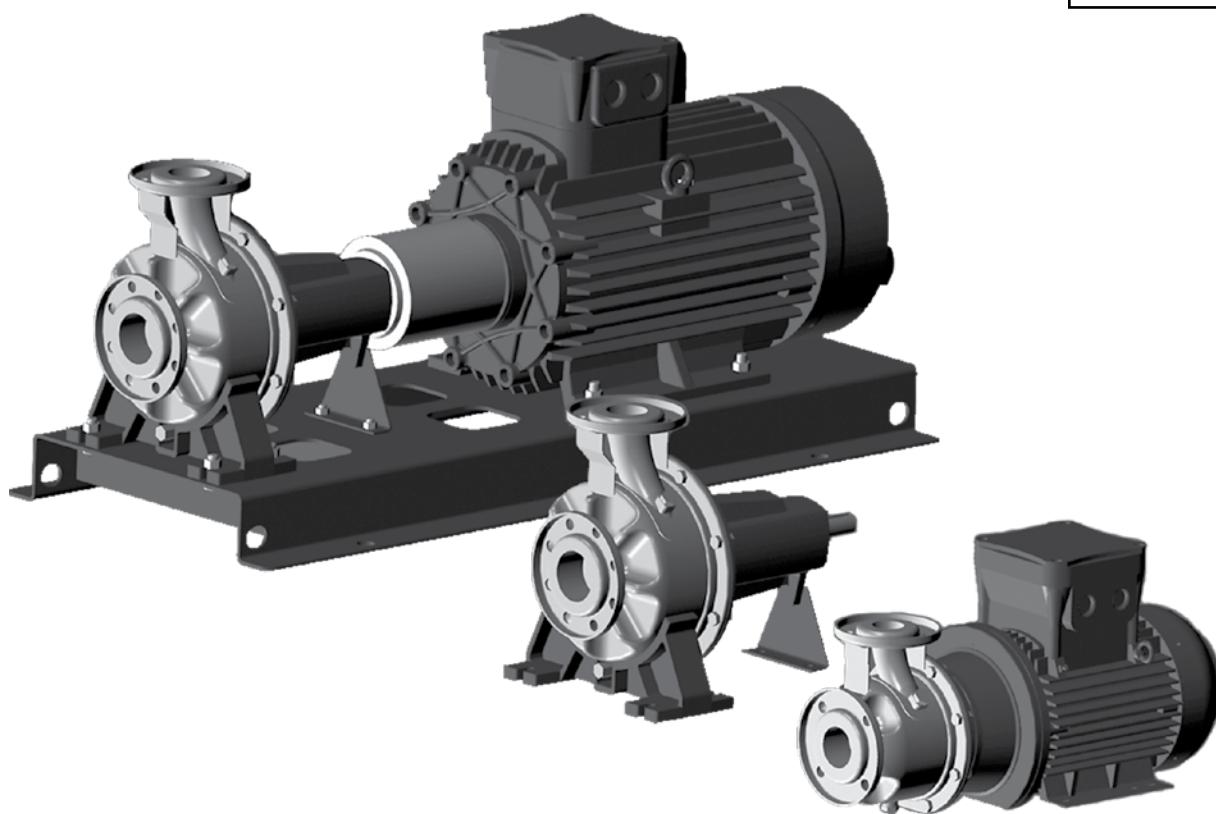

e-SH Series - ATEX Version

HORIZONTAL CENTRIFUGAL ELECTRIC PUMPS
ACCORDING TO DIRECTIVE 2014/34/EU
MADE IN AISI 316 STAINLESS STEEL

ErP 2009/125/EC

Cod. 191003051 Rev. A Ed.11/2017

 **LOWARA**
a xylem brand

CONTENTS

ATEX-approved pumps	5
General Introduction	6
Pump Working Limits	8
ATEX check list	10
Identification code	11
Rating plate	12
List of Models at 50 Hz	13
List of Models at 60 Hz	14
Pump cross-section and main components	15
Mechanical seals	17
Atex motors (ErP 2009/125/EC)	18
Dimensions and weights	29
Accessories	47
Report and declarations	51
Technical appendix	55

ATEX-APPROVED PUMPS

ATEX-approved pumps are required for operation in potentially explosive atmospheres.

Explosive atmospheres consist of air and combustible material such as gases, vapours, mists or dusts in which the explosion will spread after ignition.

Xylem ATEX-approved pumps are in accordance with the **directive 2014/34/EU**, that can be used in areas (zones) classified according to the **Atex 137 workplace directive 99/92/EC**.

Above mentioned directive is a minimum directive: some EEC (European Economic Community) countries may have stricter local rules. The user or installer is always responsible for checking that the group and category of the pump correspond to the zone classification of the installation site: this is also valid when the motor is not supplied by Xylem.

It is also responsibility of the installer/user to fill out the explosion protection document, according to the **directive 99/92/EC**, where the combination of all monitoring equipment must be described.

ESH SERIES - ATEX VERSION GENERAL INTRODUCTION

The new and improved **Lowara e-SH Series** is a high performance stainless steel centrifugal end-suction electropump with single stage, axial flanged suction port, radial flanged discharge, and horizontal shaft.

The **e-SH** is fully made in **AISI 316 stainless steel** which makes it suitable for handling water as well as nonaggressive or moderately aggressive fluids.

The following variants of the pump are available in ATEX version:



- **ESHS (stub shaft)**: Rigid-coupled with a bracket, an adaptor and a rigid coupling keyed to the standard motor shaft extension.

- **ESHF (frame mounted)**: Flexible-coupled with bracket, support, flexing coupling, aligning and anchoring base.

- **ESH (bare shaft pump)**: Version without driver.



ATEX derives its name from the French title of the 94/9/EC directive: "Appareils destinés à être utilisés en ATmospheres EXplosibles".

It combines two EU directives (**ATEX 95 – Equipment directive** and **ATEX 137 Workplace directive**) which regulate the equipment and work environment allowed in an environment with a potentially explosive atmosphere. As of July 2003, organizations in EU must follow the directives to protect all employees from explosion risks.

ATEX Certification

Notified Body SGS Baseefa, in accordance with (Article 17 of) Directive 2014/34/EU, dated 26 February 2014, performed the EU-TYPE examination and issued the certificate N°16ATEX0067X related to the design and construction of the e-SH range of pumps.

The e-SH pumps are suitable to the following:

 II 2G c IIC T4 Tamb -10°C to +55°C

- **Group II**: equipment intended for use in places with presence of explosive atmosphere, other than underground sites, mines, tunnels, etc., identified according to the criteria as per article 1 and Annex I of Directive 2014/34/EU.
- **Category 2G**: specifies the level of safety risk for restricted areas with explosive Gas (G) atmospheres. Our equipment ensures an high level of protection and is certified for use in flammable gases in Zone 1 (a location where an explosive atmosphere consisting of a mixture of air or flammable substances in the form of a gas, vapour or mist is likely to occur in normal operation occasionally) and Zone 2 (a location where the same type of the above-mentioned explosive atmosphere occurs in abnormal operation occasionally).
- **c**: describes the type of protection which has been incorporated into the design, where type of protection "c" is for constructional safety (as per ISO 80079-37).
- **IIC**: type of flammable gas present in the atmosphere where Gas Group II means the surface above ground industries and C is for the most easily ignited (e.g. hydrogen or acetylene).
- **T4**: maximum surface temperature of product must not exceed this temperature (where temperature class T4 is 135° C or 275°F).
- **Tamb -10°C to +55°C**: the permissible range of surrounding ambient environment temperature to ensure the minimum and maximum allowable surface temperatures for the product are not exceeded.

ESH SERIES - ATEX VERSION

GENERAL INTRODUCTION

The pump is intended to be driven by an electric motor with the relevant ATEX certification; and is provided with an earth path through the electrical connection of the electric motor.

The ATEX classification of the pump unit (electric pump) is the combination between the classification of the pump and the classification of the motor: the protection level of each characteristic is defined by the worse (lower protection) level between the two components.

As Xylem standard offer, the e-SH pumps in ATEX version will be fitted with motors suitable to the following:

 II 2G Ex d IIC T4 Gb IP55 Tamb -10°C to +55°C

- **d:** type of protections - flame proof (as per EN/IEC 679-1).
- **Gb:** equipment protection level for use in explosive atmospheres due to the presence of gas, with a 'high' level of protection that is not the source of ignition in normal operation or when subject to expected malfunctions, although not on a regular basis (as per EN/IEC 60079-0).

Hydraulic specifications

The performance curves of the e-SH ATEX pumps are the same as those of the standard product. Meaning that no changes on the performance curves are brought about by switching to a flameproof motor.

However, the ATEX certification requires for the pumps to have '0' tolerance on power absorption; so no overloading is allowed. In the few cases where the standard pump overloads, a larger motor is selected. In those cases, the performance curve is the same but the pump is fitted with a larger motor. If you select a bare shaft pump be sure to couple the right motor as per tables at page 13 and 14, where you can find the motor power for standard and for the correspondent ATEX pump. For the hydraulic curves please refer to the Technical catalogues of 50 and 60 Hz e-SH Series.

- **Maximum delivery:**
 - at 50 Hz: up to 240 m³/h for 2 poles range - up to 144 m³/h for 4 poles range.
 - at 60 Hz: up to 240 m³/h for 2 poles range - up to 144 m³/h for 4 poles range.
- **Maximum head:**
 - at 50 Hz: up to 110 m for 2 poles range - up to 27 m for 4 poles range.
 - at 60 Hz: up to 117 m for 2 poles range - up to 31 m for 4 poles range.
- **Hydraulic performance** compliant with ISO 9906:2012 - Grade 3B.
- **Maximum operating pressure:** 12 bar @ 50 °C and 11,3 bar @ 90 °C
- Connection dimensions according to EN 733 (except for ESH 25 models)

ESH SERIES - ATEX VERSION PUMP WORKING LIMITS

The standard e-SH ATEX pumps are suitable within the following working limits:

- **Flow rate:** do not use the pump for flow rates outside the specified flow rates on the data plate.
- **Maximum working temperature and liquid temperature intervals:** fig. "ESH_M0004_ATEX_A_ot" at page 17 shows the maximum working pressure depending on the pump version and the temperature of the pumped liquid within the allowed working temperature ranges.
- **Liquid temperature:** the maximum allowed liquid temperature is +90 °C.
- **Liquid conductivity:** liquid electrical conductivity must be greater than 1000 pS/m.
- **Liquid density/viscosity(*):** if the density and/or viscosity value of the pumped liquid exceeds the value of water, refer to your Xylem contact in the Customer Service department.
- **Liquid chemically treated and liquidity compatibility(*):** if the liquid is chemically treated (for example softened, deionized, demineralized..) and in order to choose the most suitable mechanical seal refer to your Xylem contact in the Customer Service department. To get a rough indication about the compatibility, refer to the table on page 9.
- **Ambient temperature:** the allowed range is from -10°C to +55°C.
- **Altitude of installation(*):** the pump should be at an altitude below 1000 m above sea level.
- **Humidity(*):** the maximum allowed humidity level of the environment without condensate is 95% .
- **Grounding:** the pump should be properly grounded before operating.
- **Dry running:** the pump must not be run dry.

Please note that the above-stated operating limits are mandatory. Only for (*) limits, if other specifications are needed, refer to your Xylem contact in the Customer Service department.

Pump selection

When you order an ATEX pump, you need to know the equipment group and the equipment category for which the product will be installed, the pumped liquid parameters and the other operating conditions.

It is the customer's responsibility to determine the possible explosion risk in his premises under ATEX Directive 1999/92/EC. If additional constraints are requested, to place an order, please fill out the below "ATEX Check list" form and contact your local Xylem Product Center.

Installation and pump service

For proper installation of the ESHS electric pump it is necessary to equip the motor with suitable shims. Refer to the "Accessories" chapter for the correct match on page 47.

In order to maintain an adequate safety standard only authorized Xylem Service Centers are entitled to service your pump. Service Centers are required to meet Xylem's standards at all times with regard to service levels, certification of technicians and availability of service to customers. Xylem typically audits and reviews Service Centers to ensure these high standards are consistently met.

Collect the specifications of your product, written on the data label, and contact your nearest authorized Xylem retailers that will assist you in finding one of our authorized service.

COMPATIBILITY CHART FOR MATERIALS IN CONTACT WITH MOST COMMONLY USED LIQUIDS

The below table indicates the compatibility of materials depending on the pumped liquid. Check the specific weight of the liquid or the viscosity as this could affect the power input of the motor and hydraulic performance.

The below data are just indicative, for further details, please contact the sales network.

LIQUID	CONCENTRATION (%)	TEMPERATURE MIN/MAX (°C)	SPECIFIC WEIGHT (kg/dm ³)	RECOMMENDED SEAL	ELASTOMER
Alkaline degreaser	5	80		Q ₁ Q ₁ VGG	V
Aluminium sulfate	30	-5 +50	2,71	Q ₁ Q ₁ EGG	E
Ammonium sulfate	10	-10 +60	1,77	Q ₁ Q ₁ EGG	E
Boric acid	saturated	-10 +90	1,43	Q ₁ Q ₁ VGG	V
Caustic soda	25	0 +70	2,13	Q ₁ Q ₁ EGG	E
Cleaning products	10	-5 +90		Q ₁ Q ₁ VGG	V
Copper sulfate	20	0 +30	2,28	Q ₁ Q ₁ VGG	V
Cutting fluid	100	85	0,90	VCVGG	V
Diathermic oil	100	85	0,90	VCVGG	V
Diesel	100	85		VCVGG	V
Ethyl alcohol	100	35	0,81	VCEGG	E
Ethylene glycol	30	-30 +90		Q ₁ Q ₁ EGG	E
Hydraulic oil	100	85		VCVGG	V
Hydrochloric acid	2	-5 +25	1,20	Q ₁ Q ₁ VGG	V
Hydroxide sodium	25	0 +70		Q ₁ Q ₁ EGG	E
Mineral oil	100	85	0,94	VCVGG	V
Nitric acid	50	-5 +30	1,48	Q ₁ Q ₁ VGG	V
Phosphates-polyphosphates	10	-5 +90		Q ₁ Q ₁ VGG	V
Propylene glycol	30	-30 +90		Q ₁ Q ₁ EGG	E
Seawater	Sat.	75		VCVGG	V
Sodium hypochlorite	1	-10 +25		Q ₁ Q ₁ VGG	V
Sodium sulfate	15	-10 +40	2,60	Q ₁ Q ₁ EGG	E
Tartaric acid	50	-10 +25	1,76	Q ₁ Q ₁ VGG	V
Water detergents, mineral oi	10	-5 +80		Q ₁ Q ₁ VGG	V
Whisky	100	-5 +90		Q ₁ Q ₁ EGG	E

tab-comp-esh_atex-en_a_tm

ESH SERIES - ATEX VERSION
ATEX CHECK LIST

ATEX - Check list

1. Specify eSH REFERENCE MODEL *PLEASE FILL IN*

Flow (capacity)	<input type="text"/>	[m ³ /h]	at Head
	<input type="text"/>		[m]
Suction head (+ / -)	<input type="text"/>	[m]	

2. General condition XYLEM ATEX EQUIPMENT *PLEASE FILL TO CONFIRM*

Group II (2014/34/UE)	<input checked="" type="checkbox"/>	Category 2 (2014/34/UE)	<input type="checkbox"/>	Gas, vapours, mists (G)	<input type="checkbox"/>
Pump protection "c"	<input type="checkbox"/>	Temp. Class T4 (135°C)	<input type="checkbox"/>	Amb.Temp. -10+55 [°C]	<input type="checkbox"/>
		eSH Explosion Group IIC	<input type="checkbox"/>		
No dry run	<input type="checkbox"/>			Humidity ≤ 95%	<input type="checkbox"/>
ρ Liquid > 1000 [pS/m]	<input type="checkbox"/>	Ground connect. needed	<input type="checkbox"/>	Temp. liq. MAX 90 [°C]	<input type="checkbox"/>

3. ZONE, Ambient condition and Nature of pumped liquid *PLEASE FILL IN*

ZONE (1999/92/CE)	<input type="text" value="1"/>	<input type="text" value="2"/>	Altitude	<input type="text"/>	[m]
Liquid 1				Percentage	<input type="text"/>
Trade / chemical name	<input type="text"/>				%
Liquid 2				Percentage	<input type="text"/>
Trade / chemical name	<input type="text"/>				%

4. MOTOR *PLEASE FILL IN*

	STANDARD	OPTION	SPECIFY
Phase	3 ph	no	
Motor protection	Ex d	Ex de	
IP	55	65	
Efficiency	IE2	IE3	
Inverter use	NO	YES	
Auxiliary terminal box	NO	YES →	Type
Protection driven	NO	YES →	PTC or PT100
Space heaters	NO	YES →	Voltage
Frequency	50	60	
pole	2	4	
Voltage	check catalogue	→	

Date of issue : _____

ESH SERIES - ATEX VERSION IDENTIFICATION CODE

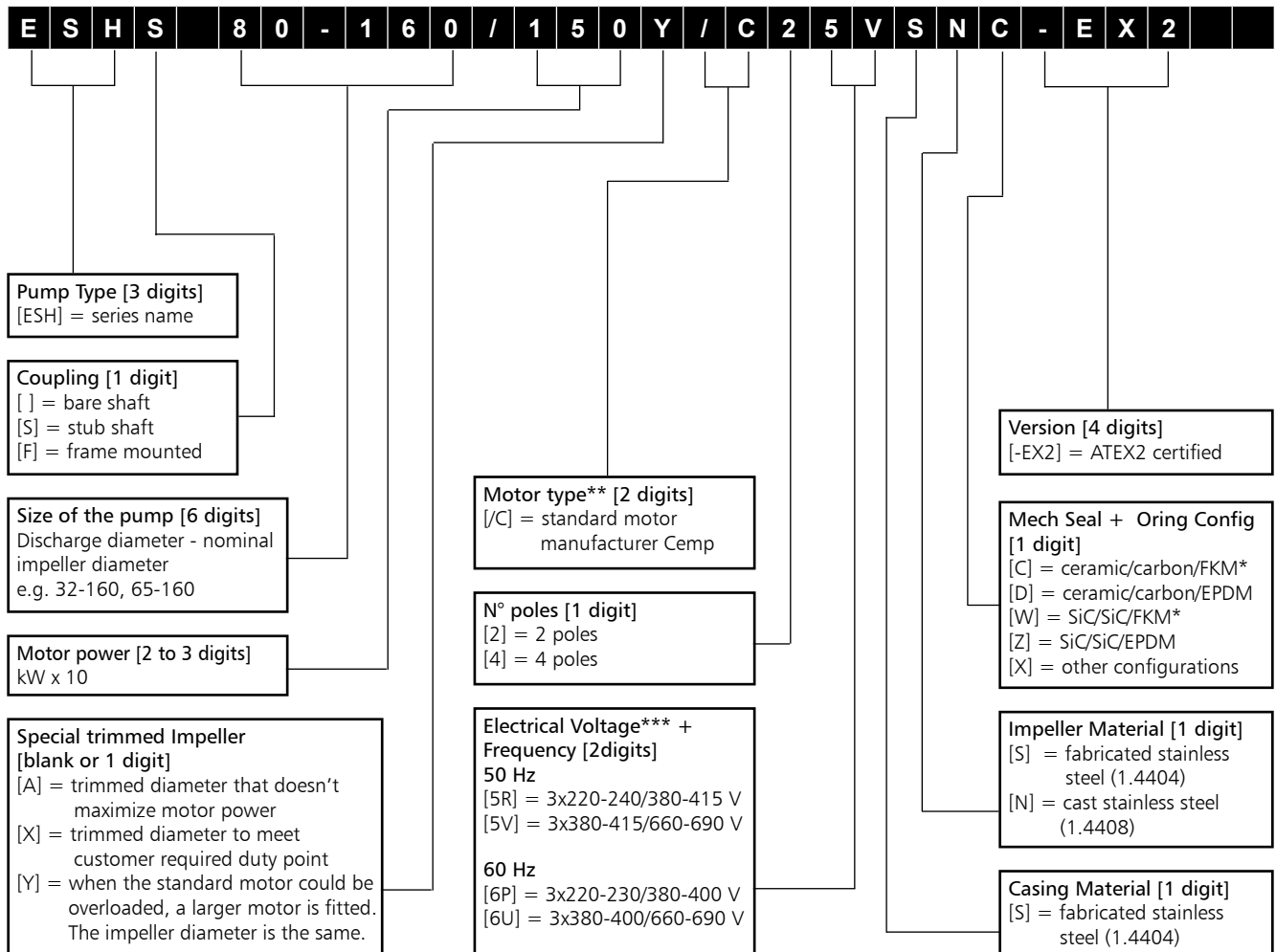

* FPM (old ISO), FKM (ASTM & new ISO)

** Cemp motor as standard, other motor on request.

*** Other voltage range availability, please contact the Customer Service for evaluation.

EXAMPLES

ESH S 80-160/150Y/C25VSN C-EX2

End-suction, electric pump with stub shaft coupling, DN 80 nominal discharge port, 160 mm nominal impeller diameter, 15 kW rated motor power, CEMP model, 2-pole, 50 Hz 380-415/660-690 V, fabricated stainless steel casing, cast stainless steel impeller, Ceramic/Carbon/FKM mechanical seal, ATEX version. In this case, since the standard motor could be overloaded, a larger motor is fitted as signified by the Y. The performance curves of ESH S 80-160/110/P25VSN A pump and ESH S 80-160/150Y/C25VSN C-EX2 pump are the same because the impeller diameter is the same.

ESH F 25-125/11/C25RSN C-EX2

End-suction, electric pump with frame mounted coupling, DN 25 nominal discharge port, 125 mm nominal impeller diameter, 1,1 kW rated motor power, CEMP model, 2-pole, 50 Hz 220-240/380-415 V, fabricated stainless steel casing, cast stainless steel impeller, Ceramic/Carbon/FKM mechanical seal, ATEX version.

**ESH SERIES - ATEX VERSION
RATING PLATE**

ESH - PUMP ONLY

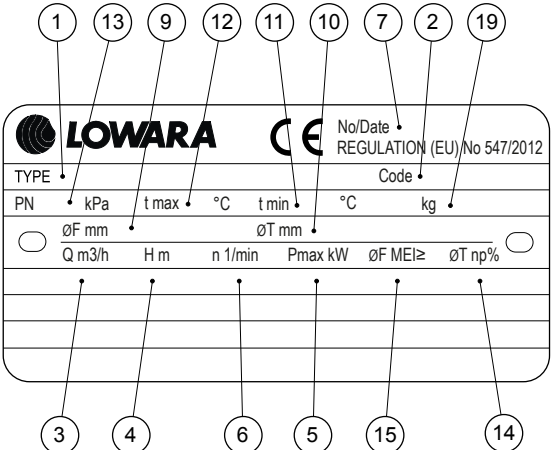

TYPE		No/Date REGULATION (EU) No 547/2012		Code		kg	
PN	kPa	t max °C	t min °C				
∅F mm	H m	n 1/min	Pmax kW	∅F MEI≥	∅T np%		

ESHS - ELECTRIC PUMP

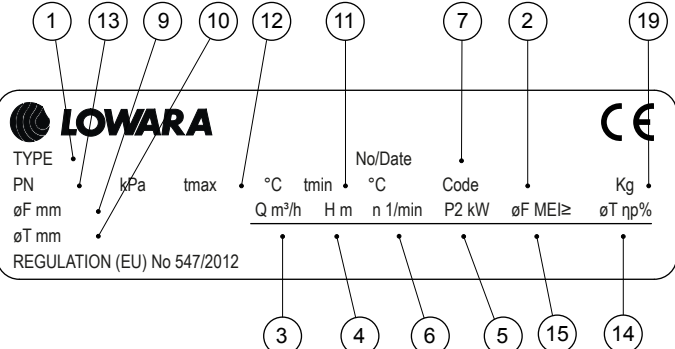

TYPE		No/Date		Code		Kg	
PN	kPa	tmax °C	tmin °C				
∅F mm	H m	n 1/min	P2 kW	∅F MEI≥	∅T np%		

ESHF - ELECTRIC PUMP

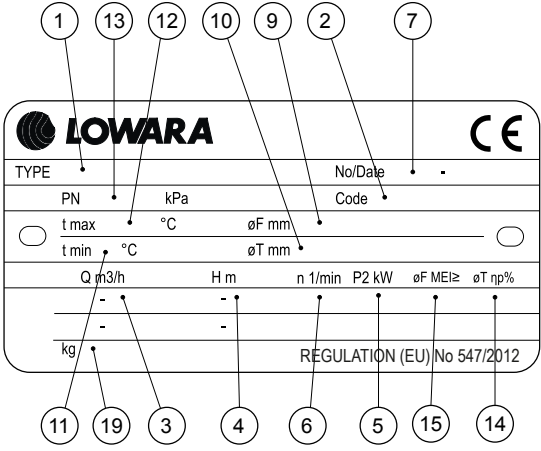

TYPE		No/Date		Code		kg	
PN	kPa	t max °C	t min °C				
∅F mm	H m	n 1/min	P2 kW	∅F MEI≥	∅T np%		



LOWARA Xylem Service Italia S.r.l. - Via Vittorio Lombardi 14
36075 Montecchio Maggiore- (VI)-ITALY

CE **Ex** **II 2G c IIC T4**

Cert.Number: Baseefa16ATEX0067X **Tamb -10°C +55°C**

168279010

LEGEND

- 1 - Pump type
- 2 - Pump code
- 3 - Flow range
- 4 - Head range
- 5 - Nominal or maximum pump power
- 6 - Speed
- 7 - Serial number, or order number + order position number
- 9 - Full impeller diameter (only filled in for trimmed impellers)
- 10 - Trimmed impeller diameter (only filled in for trimmed impellers)
- 11 - Minimum operating liquid temperature
- 12 - Maximum operating liquid temperature
- 13 - Maximum operating pressure
- 14 - Hydraulic efficiency in best efficiency point (50 Hz)
- 15 - Minimum efficiency index MEI, as per Regulation (EU) No 547/2012 (50 Hz)
- 19 - Weight

LEGEND

- 1 - Electric pump unit type
- 2 - Electric pump unit code
- 3 - Flow range
- 4 - Head range
- 5 - Nominal or maximum pump power
- 6 - Speed
- 7 - Serial number, or order number + order position number
- 9 - Full impeller diameter (only filled in for trimmed impellers)
- 10 - Trimmed impeller diameter (only filled in for trimmed impellers)
- 11 - Minimum operating liquid temperature
- 12 - Maximum operating liquid temperature
- 13 - Maximum operating pressure
- 14 - Hydraulic efficiency in best efficiency point (50 Hz)
- 15 - Minimum efficiency index MEI, as per Regulation (EU) No 547/2012 (50 Hz)
- 19 - Weight

Notes for electric pump unit:

- check ATEX classification of the motor and combine it with the classification of the pump.
- refer to motor data plate for electrical data.

ESH SERIES - ATEX VERSION

LIST OF MODELS AT 50 Hz

All the available ATEX eSH are listed in the tables below. For the hydraulic performances please refer to the correspondent standard version pump curve (eSH range 50 Hz technical catalogue).

ESH 2 POLES MODELS					
STANDARD VERSION	kW	ATEX VERSION	kW	ESHS	ESH / ESHF
25-125/07/S	0,75	25-125/11Y/C	1,1	•	•
25-125/11/P	1,1	25-125/11/C	1,1	•	•
25-160/15/P	1,5	25-160/22Y/C	2,2	•	•
25-160/22/P	2,2	25-160/22/C	2,2	•	•
25-200/30/P	3	25-200/30/C	3	•	•
25-200/40/P	4	25-200/40/C	4	•	•
25-250/55/P	5,5	25-250/55/C	5,5	•	•
25-250/75/P	7,5	25-250/75/C	7,5	•	•
25-250/110/P	11	25-250/110/C	11	•	•
32-125/07/S	0,75	32-125/11Y/C	1,1	•	•
32-125/11/P	1,1	32-125/11/C	1,1	•	•
32-160/15/P	1,5	32-160/22Y/C	2,2	•	•
32-160/22/P	2,2	32-160/22/C	2,2	•	•
32-200/30/P	3	32-200/30/C	3	•	•
32-200/40/P	4	32-200/40/C	4	•	•
32-250/55/P	5,5	32-250/55/C	5,5	•	•
32-250/75/P	7,5	32-250/75/C	7,5	•	•
32-250/110/P	11	32-250/110/C	11	•	•
40-125/11/P	1,1	40-125/11/C	1,1	•	•
40-125/15/P	1,5	40-125/15/C	1,5	•	•
40-125/22/P	2,2	40-125/22/C	2,2	•	•
40-160/30/P	3	40-160/40Y/C	4	•	•
40-160/40/P	4	40-160/55Y/C	5,5	•	•
40-200/55/P	5,5	40-200/75Y/C	7,5	•	•
40-200/75/P	7,5	40-200/110Y/C	11	•	•
40-250/110A/P	11	40-250/110A/C	11	•	•
40-250/110/P	11	40-250/150Y/C	15	•	•
40-250/150/P	15	40-250/150/C	15	•	•
50-125/22/P	2,2	50-125/22/C	2,2	•	•
50-125/30/P	3	50-125/30/C	3	•	•
50-125/40/P	4	50-125/55Y/C	5,5	•	•
50-160/55/P	5,5	50-160/75Y/C	7,5	•	•
50-160/75/P	7,5	50-160/75/C	7,5	•	•
50-200/110A/P	11	50-200/110A/C	11	•	•
50-200/110/P	11	50-200/150Y/C	15	•	•
50-250/150/P	15	50-250/150/C	15	•	•
50-250/185/P	18,5	50-250/185/C	18,5	•	•
50-250/220/P	22	50-250/220/C	22	•	•
65-160/40/P	4	65-160/40/C	4	•	•
65-160/55/P	5,5	65-160/55/C	5,5	•	•
65-160/75/P	7,5	65-160/75/C	7,5	•	•
65-160/110A/P	11	65-160/110A/C	11	•	•
65-160/110/P	11	65-160/110/C	11	•	•
65-200/150/P	15	65-200/150/C	15	•	•
65-200/185/P	18,5	65-200/185/C	18,5	•	•
65-200/220/P	22	65-200/220/C	22	•	•
65-250/300/W	30	65-250/370Y/C	37	-	•
65-250/370/W	37	65-250/450Y/C	45	-	•
80-160/110/P	11	80-160/150Y/C	15	•	•
80-160/150/P	15	80-160/150/C	15	•	•
80-160/185/P	18,5	80-160/185/C	18,5	•	•
80-200/220/P	22	80-200/300Y/C	30	•	•
80-200/300/W	30	80-200/370Y/C	37	-	•
80-200/370/W	37	80-200/450Y/C	45	-	•
80-250/450/W	45	80-250/450/C	45	-	•
80-250/550/W	55	80-250/550/C	55	-	•
80-250/750/W	75	80-250/750/C	75	-	•

ESH 4 POLES MODELS					
STANDARD VERSION	kW	ATEX VERSION	kW	ESHS	ESH / ESHF
25-125/02A	0,25	25-125/02A/C	0,25	-	•
25-125/02	0,25	25-125/02/C	0,25	-	•
25-160/02A	0,25	25-160/02A/C	0,25	-	•
25-160/02	0,25	25-160/03Y/C	0,37	-	•
25-200/03	0,37	25-200/03/C	0,37	-	•
25-200/05	0,55	25-200/05/C	0,55	-	•
25-250/07	0,75	25-250/07/C	0,75	•	•
25-250/11	1,1	25-250/11/C	1,1	•	•
25-250/15	1,5	25-250/15/C	1,5	•	•
32-125/02A	0,25	32-125/02A/C	0,25	-	•
32-125/02	0,25	32-125/02/C	0,25	-	•
32-160/02A	0,25	32-160/02A/C	0,25	-	•
32-160/02	0,25	32-160/03Y/C	0,37	-	•
32-200/03	0,37	32-200/03/C	0,37	-	•
32-200/05	0,55	32-200/05/C	0,55	-	•
32-250/07	0,75	32-250/07/C	0,75	•	•
32-250/11	1,1	32-250/11/C	1,1	•	•
32-250/15	1,5	32-250/15/C	1,5	•	•
40-125/02A	0,25	40-125/02A/C	0,25	-	•
40-125/02	0,25	40-125/02/C	0,25	-	•
40-160/03	0,37	40-160/03/C	0,37	-	•
40-160/05	0,55	40-160/05/C	0,55	-	•
40-200/07	0,75	40-200/07/C	0,75	•	•
40-200/11	1,1	40-200/11/C	1,1	•	•
40-250/11	1,1	40-250/15Y/C	1,5	•	•
40-250/15	1,5	40-250/15/C	1,5	•	•
40-250/22	2,2	40-250/22/C	2,2	•	•
50-125/02	0,25	50-125/02/C	0,25	-	•
50-125/03	0,37	50-125/03/C	0,37	-	•
50-125/05	0,55	50-125/05/C	0,55	-	•
50-160/07	0,75	50-160/07/C	0,75	•	•
50-160/11	1,1	50-160/11/C	1,1	•	•
50-200/11	1,1	50-200/11/C	1,1	•	•
50-200/15	1,5	50-200/15/C	1,5	•	•
50-250/22A	2,2	50-250/22A/C	2,2	•	•
50-250/22	2,2	50-250/22/C	2,2	•	•
50-250/30	3	50-250/30/C	3	•	•
65-160/05	0,55	65-160/07Y/C	0,75	•	•
65-160/07	0,75	65-160/07/C	0,75	•	•
65-160/11A	1,1	65-160/11A/C	1,1	•	•
65-160/11	1,1	65-160/11/C	1,1	•	•
65-160/15	1,5	65-160/15/C	1,5	•	•
65-200/15	1,5	65-200/22Y/C	2,2	•	•
65-200/22	2,2	65-200/22/C	2,2	•	•
65-200/30	3	65-200/30/C	3	•	•
65-250/40	4	65-250/40/C	4	•	•
65-250/55	5,5	65-250/55/C	5,5	•	•
80-160/15	1,5	80-160/15/C	1,5	•	•
80-160/22A	2,2	80-160/22A/C	2,2	•	•
80-160/22	2,2	80-160/22/C	2,2	•	•
80-200/30	3	80-200/30/C	3	•	•
80-200/40	4	80-200/55Y/C	5,5	•	•
80-250/55	5,5	80-250/55/C	5,5	•	•
80-250/75	7,5	80-250/75/C	7,5	•	•
80-250/110	11	80-250/110/C	11	•	•

• = Available

ESH_models-ATEX-50-en_a_sc

ESH SERIES - ATEX VERSION LIST OF MODELS AT 60 Hz

All the available ATEX eSH are listed in the tables below. For the hydraulic performances please refer to the correspondent standard version pump curve (eSH range 60 Hz technical catalogue).

ESH 2 POLES MODELS					
STANDARD VERSION	kW	ATEX VERSION	kW	ESHS	ESH / ESHF
25-125/11	1,1	25-125/11/C	1,1	•	•
25-160/15	1,5	25-160/22Y/C	2,2	•	•
25-160/22	2,2	25-160/22/C	2,2	•	•
25-200/30	3	25-200/30/C	3	•	•
25-200/40	4	25-200/40/C	4	•	•
25-250/55	5,5	25-250/55/C	5,5	•	•
25-250/75	7,5	25-250/75/C	7,5	•	•
25-250/110A	11	25-250/110A/C	11	•	•
25-250/110	11	25-250/110/C	1,1	•	•
32-125/11	1,1	32-125/11/C	1,1	•	•
32-160/15	1,5	32-160/22Y/C	2,2	•	•
32-160/22	2,2	32-160/22/C	2,2	•	•
32-200/30	3	32-200/30/C	3	•	•
32-200/40	4	32-200/55Y/C	5,5	•	•
32-250/55	5,5	32-250/55/C	5,5	•	•
32-250/75	7,5	32-250/75/C	7,5	•	•
32-250/110A	11	32-250/110A/C	11	•	•
32-250/110	11	32-250/110/C	11	•	•
40-125/15	1,5	40-125/15/C	1,5	•	•
40-125/22	2,2	40-125/22/C	2,2	•	•
40-160/30	3	40-160/40Y/C	4	•	•
40-160/40	4	40-160/40/C	4	•	•
40-200/55	5,5	40-200/75Y/C	7,5	•	•
40-200/75	7,5	40-200/75/C	7,5	•	•
40-250/110A	11	40-250/110A/C	11	•	•
40-250/110	11	40-250/110/C	11	•	•
40-250/150	15	40-250/150/C	15	•	•
50-125/30	3	50-125/30/C	3	•	•
50-125/40	4	50-125/55Y/C	5,5	•	•
50-160/55	5,5	50-160/55/C	5,5	•	•
50-160/75	7,5	50-160/75/C	7,5	•	•
50-200/110A	11	50-200/110A/C	11	•	•
50-200/110	11	50-200/110/C	11	•	•
50-250/150	15	50-250/150/C	15	•	•
50-250/185	18,5	50-250/185/C	18,5	•	•
50-250/220	22	50-250/220/C	22	•	•
65-160/55	5,5	65-160/55/C	5,5	•	•
65-160/75	7,5	65-160/75/C	7,5	•	•
65-160/110A	11	65-160/110A/C	11	•	•
65-160/110	11	65-160/110/C	11	•	•
65-200/150	15	65-200/150/C	15	•	•
65-200/185	18,5	65-200/185/C	18,5	•	•
65-200/220	22	65-200/220/C	22	•	•
65-250/300	30	65-250/300/C	30	•	•
65-250/370	37	65-250/370/C	37	-	•
80-160/150	15	80-160/150/C	15	•	•
80-160/185	18,5	80-160/185/C	18,5	•	•
80-200/220	22	80-200/220/C	22	•	•
80-200/300	30	80-200/370Y/C	37	-	•
80-200/370	37	80-200/370/C	37	-	•
80-250/450	45	80-250/450/C	45	-	•
80-250/550	55	80-250/550/C	55	-	•
80-250/750	75	80-250/750/C	75	-	•

ESH 4 POLES MODELS					
STANDARD VERSION	kW	ATEX VERSION	kW	ESHS	ESH / ESHF
25-125/02	0,25	25-125/02/S	0,25	-	•
25-160/02	0,25	25-160/02/S	0,25	-	•
25-160/03	0,37	25-160/03/S	0,37	-	•
25-200/03	0,37	25-200/03/S	0,37	-	•
25-200/05	0,55	25-200/07Y/S	0,75	-	•
25-250/07	0,75	25-250/07/X	0,75	•	•
25-250/11	1,1	25-250/15Y/P	1,5	•	•
25-250/15	1,5	25-250/15/P	1,5	•	•
32-125/02	0,25	32-125/02/S	0,25	-	•
32-160/02	0,25	32-160/02/S	0,25	-	•
32-160/03	0,37	32-160/03/S	0,37	-	•
32-200/03	0,37	32-200/03/S	0,37	-	•
32-200/05	0,55	32-200/07Y/S	0,75	-	•
32-250/07	0,75	32-250/07/X	0,75	•	•
32-250/11	1,1	32-250/11/P	1,1	•	•
32-250/15	1,5	32-250/15/P	1,5	•	•
40-125/02	0,25	40-125/02/S	0,25	-	•
40-125/03	0,37	40-125/03/S	0,37	-	•
40-160/03	0,37	40-160/03/S	0,37	-	•
40-160/05	0,55	40-160/05/S	0,55	-	•
40-200/07	0,75	40-200/07/X	0,75	•	•
40-200/11	1,1	40-200/11/P	1,1	•	•
40-250/11	1,1	40-250/11/P	1,1	•	•
40-250/15	1,5	40-250/15/P	1,5	•	•
40-250/22	2,2	40-250/22/P	2,2	•	•
50-125/03	0,37	50-125/03/S	0,37	-	•
50-125/05	0,55	50-125/05/S	0,55	-	•
50-160/07	0,75	50-160/07/X	0,75	•	•
50-160/11	1,1	50-160/11/P	1,1	•	•
50-200/11	1,1	50-200/15Y/P	1,5	•	•
50-200/15	1,5	50-200/15/P	1,5	•	•
50-250/22A	2,2	50-250/22A/P	2,2	•	•
50-250/22	2,2	50-250/30Y/P	3	•	•
50-250/30	3	50-250/40Y/P	4	•	•
65-160/07	0,75	65-160/07/X	0,75	•	•
65-160/11A	1,1	65-160/11A/P	1,1	•	•
65-160/11	1,1	65-160/15Y/P	1,5	•	•
65-160/15	1,5	65-160/15/P	1,5	•	•
65-200/15	1,5	65-200/22Y/P	2,2	•	•
65-200/22	2,2	65-200/22/P	2,2	•	•
65-200/30	3	65-200/30/P	3	•	•
65-250/40	4	65-250/40/P	4	•	•
65-250/55	5,5	65-250/55/P	5,5	•	•
80-160/22A	2,2	80-160/22A/P	2,2	•	•
80-160/22	2,2	80-160/22/P	2,2	•	•
80-200/30	3	80-200/30/P	3	•	•
80-200/40	4	80-200/40/P	4	•	•
80-250/55	5,5	80-250/55/P	5,5	•	•
80-250/75	7,5	80-250/75/P	7,5	•	•
80-250/110	11	80-250/110/P	11	•	•

• = Available

ESH_models-ATEX-60-en_a_sc

ESHS SERIES - ATEX VERSION ELECTRIC PUMP CROSS-SECTION AND MAIN COMPONENTS

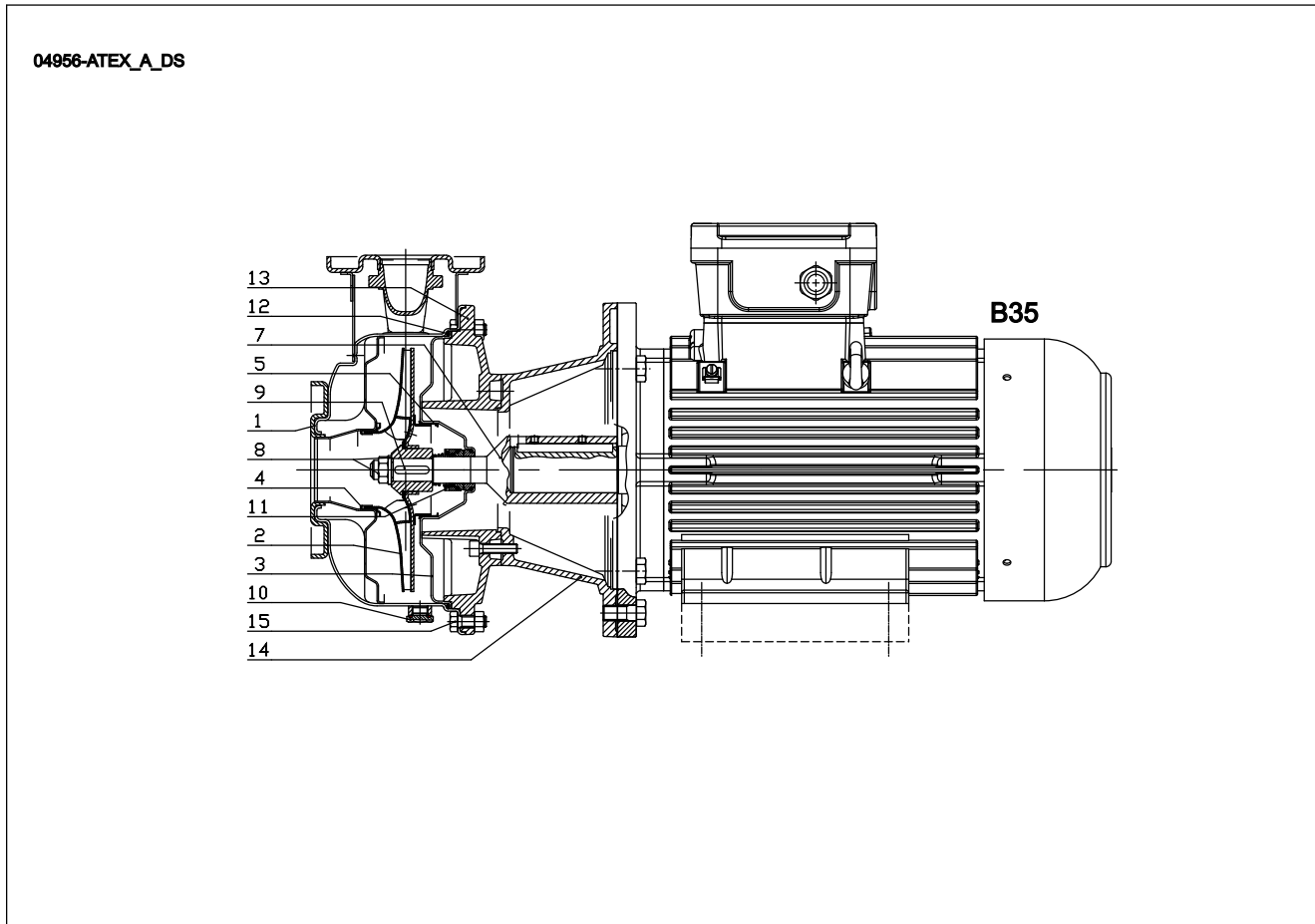

REF. N.	NAME	MATERIAL	REFERENCE STANDARDS	
			EUROPE	USA
1	Pump body	Stainless steel	EN 10088-1-X2CrNiMo17-12-2 (1.4404)	AISI 316L
2	Impeller	Stainless steel	EN 10088-1-X2CrNiMo17-12-2 (1.4404)	AISI 316L
	Impeller (25-125, 32-125, DN65, DN80)	Stainless steel	EN 10213-4-GX5CrNiMo19-11-2 (1.4408)	ASTM CF8M (cast AISI 316)
3	Seal housing	Stainless steel	EN 10088-1-X2CrNiMo17-12-2 (1.4404)	AISI 316L
4	Wear ring	Stainless steel	EN 10088-1-X2CrNiMo17-12-2 (1.4404)	AISI 316L
5	Counterwear ring	Stainless steel	EN 10088-1-X2CrNiMo17-12-2 (1.4404)	AISI 316L
7	Rigid shaft coupling	Stainless steel	EN 10088-1-X2CrNiMo17-12-2 (1.4404)	AISI 316L
8	Impeller locknut and washer	Stainless steel	EN 10088-1-X5CrNiMo17-12-2 (1.4401)	AISI 316
9	Tab	Acciaio inox	EN 10088-1-X2CrNiMo17-12-2 (1.4404)	AISI 316L
10	Fill/drain plugs	Stainless steel	EN 10088-1-X5CrNiMo17-12-2 (1.4401)	AISI 316
11	Mechanical seal ATEX	Ceramic / Carbon / FKM (standard version)		
12	Elastomers	FKM (standard version)		
13	Adapter *	Aluminium	EN 1706-AC-AISI11Cu2 (Fe) (AC46100)	-
	Adapter	Cast iron	EN 1561-GJL-200 (JL1030)	ASTM Class 25
14	Adapter motor coupling	Cast iron	EN 1561-GJL-200 (JL1030)	ASTM Class 25
15	Pump body fastening bolts & screws	Galvanized steel		

* 2/4 pole: 25/32/40-125, 25/32/40-160, 25/32/40-200

ESHS-atex-en_a_tm

ESH, ESHF SERIES - ATEX VERSION ELECTRIC PUMP CROSS-SECTION AND MAIN COMPONENTS

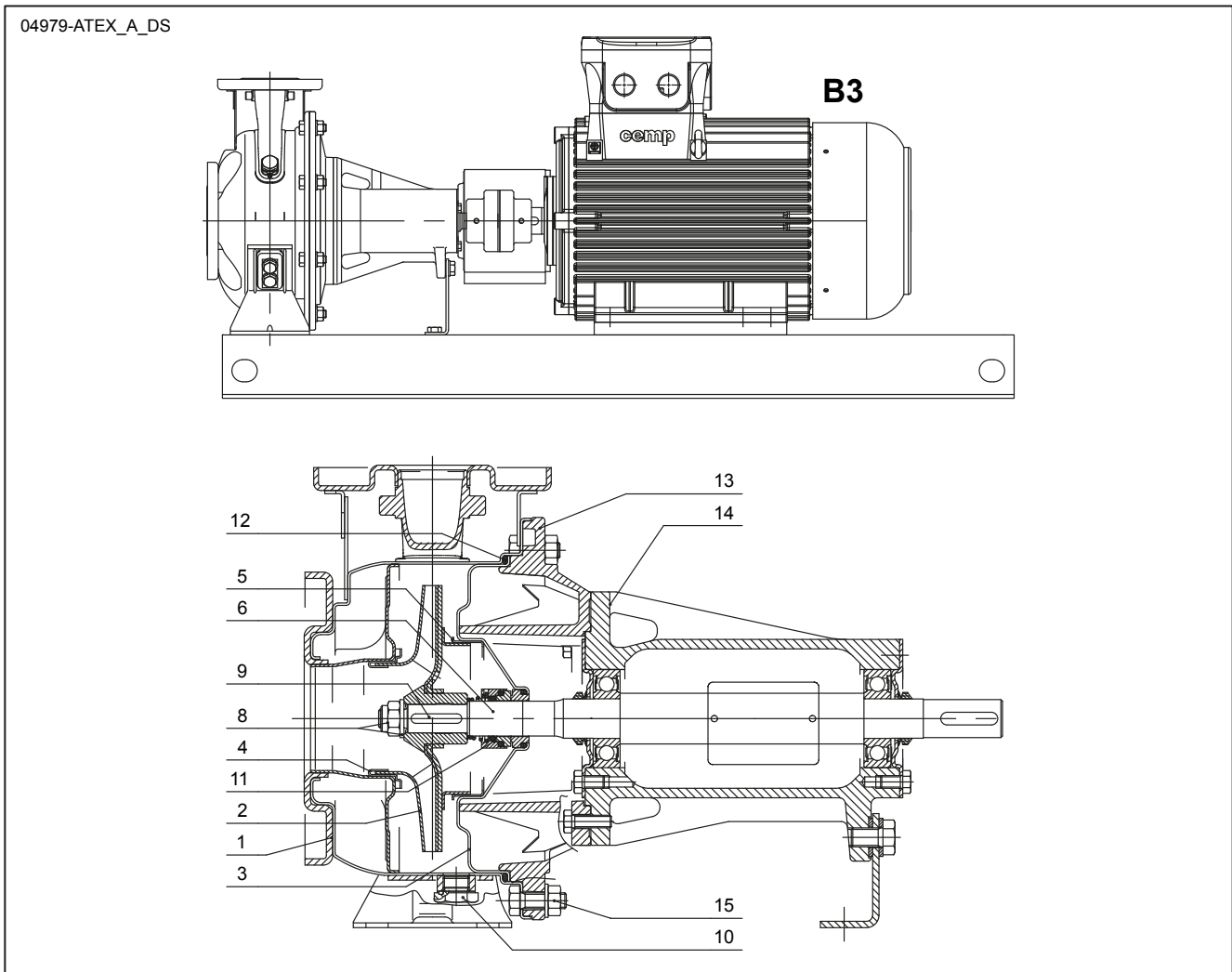

REF. N.	NAME	MATERIAL	REFERENCE STANDARDS	
			EUROPE	USA
1	Pump body	Stainless steel	EN 10088-1-X2CrNiMo17-12-2 (1.4404)	AISI 316L
2	Impeller	Stainless steel	EN 10088-1-X2CrNiMo17-12-2 (1.4404)	AISI 316L
	Impeller (25-125, 32-125, DN65, DN80)	Stainless steel	EN 10213-4-GX5CrNiMo19-11-2 (1.4408)	ASTM CF8M (cast AISI 316)
3	Seal housing	Stainless steel	EN 10088-1-X2CrNiMo17-12-2 (1.4404)	AISI 316L
4	Wear ring	Stainless steel	EN 10088-1-X2CrNiMo17-12-2 (1.4404)	AISI 316L
5	Counterwear ring	Stainless steel	EN 10088-1-X2CrNiMo17-12-2 (1.4404)	AISI 316L
6	Shaft extension	Stainless steel	EN 10088-1-X2CrNiMo17-12-2 (1.4404)	AISI 316L
8	Impeller locknut and washer	Stainless steel	EN 10088-1-X5CrNiMo17-12-2 (1.4401)	AISI 316
9	Tab	Stainless steel	EN 10088-1-X2CrNiMo17-12-2 (1.4404)	AISI 316L
10	Fill/drain plugs	Stainless steel	EN 10088-1-X5CrNiMo17-12-2 (1.4401)	AISI 316
11	ATEX mechanical seal	Ceramic / Carbon / FKM (standard version)		
12	Elastomers	FKM (standard version)		
13	Adapter *	Aluminium	EN 1706-AC-AISi11Cu2 (Fe) (AC46100)	-
	Adapter	Cast iron	EN 1561-GJL-200 (JL1030)	ASTM Class 25
14	Transmission support body	Cast iron	EN 1561-GJL-200 (JL1030)	ASTM Class 25
15	Pump body fastening bolts & screws	Galvanized steel		

* 2/4 pole: 25/32/40-125, 25/32/40-160, 25/32/40-200

ESHF-atex-en_a_tm

ESH SERIES - ATEX VERSION MECHANICAL SEALS

(Mechanical seal with mounting dimensions according to EN 12756 and ISO 3069.)

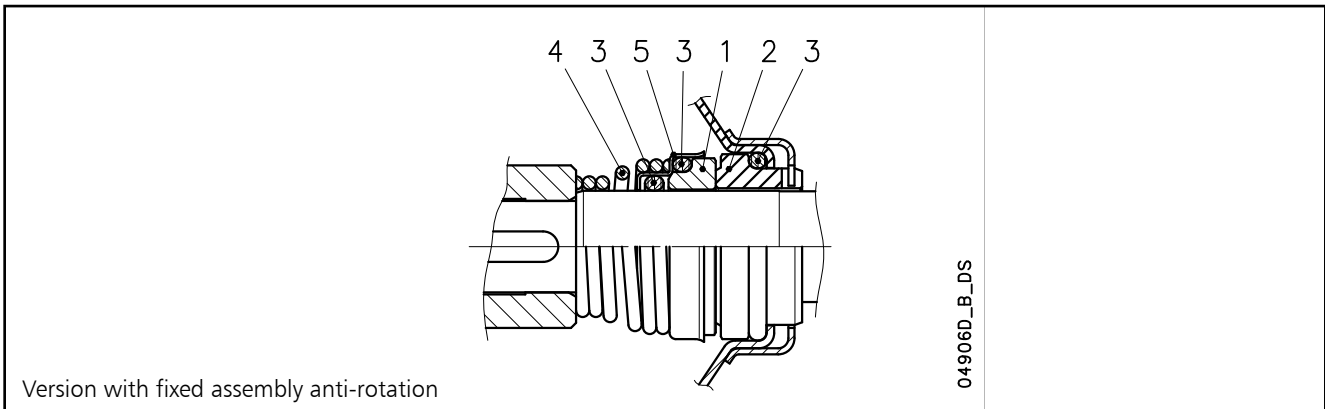

POSITION 1 - 2	POSITION 3	POSITION 4 - 5
C : Resin Low impregnated carbon	E : EPDM	G : AISI 316
Q₁ : Silicon carbide	V : FKM (FPM)	
V : Ceramic		

ESH_ten-mec_atex-en_a_tm

TYPE	POSITION					TEMPERATURE (°C)
	1 ROTATING ASSEMBLY	2 FIXED ASSEMBLY	3 ELASTOMERS	4 SPRINGS	5 OTHER COMPONENTS	
STANDARD MECHANICAL SEAL						
V C V G G	V	C	V	G	G	-10 +90
OTHER MECHANICAL SEAL TYPES						
Q ₁ Q ₁ V G G	Q ₁	Q ₁	V	G	G	-10 +90
V C E G G	V	C	E	G	G	-30 +90
Q ₁ Q ₁ E G G	Q ₁	Q ₁	E	G	G	-30 +90

sh_tipi-ten-mec-atex-en_a_tc

PRESSURE/TEMPERATURE APPLICATION LIMITS FOR COMPLETE PUMP

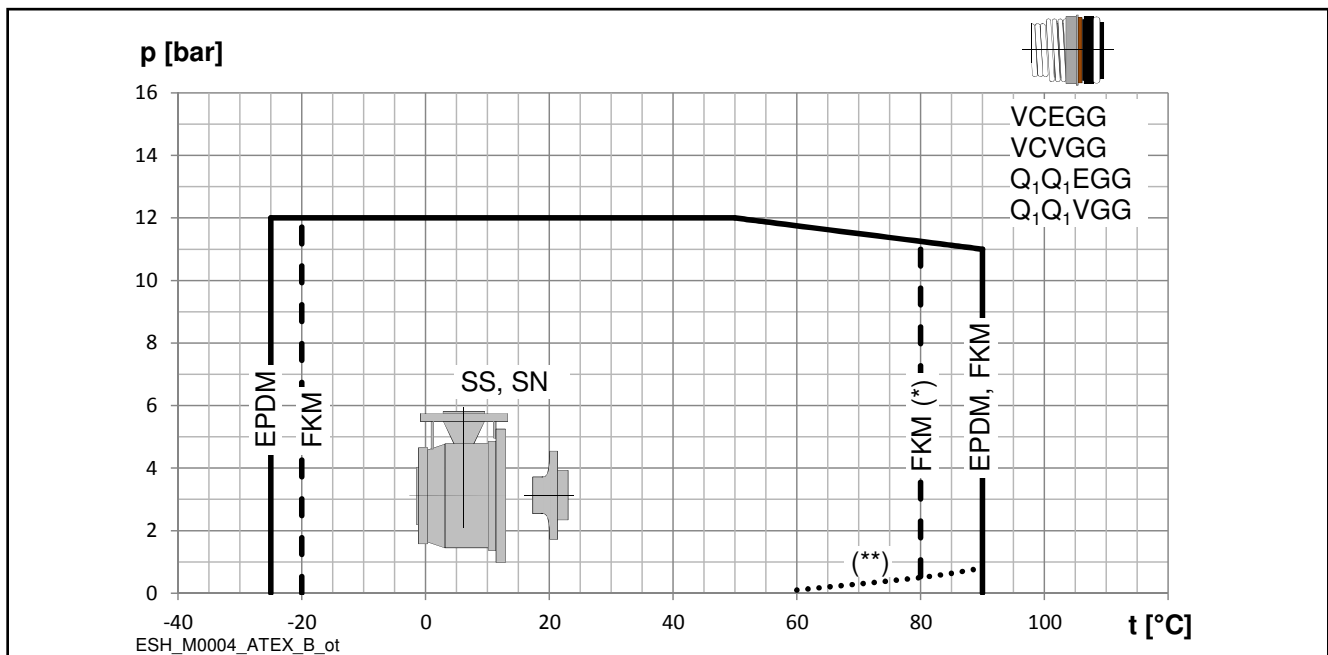

(*) hot water (**) minimum pressure required at mechanical seal (hot water; could be different in case of other liquids).

**ESH SERIES - ATEX VERSION
ATEX MOTORS**

The e-SHS ATEX pumps will be fitted with motors suitable to the following:

 **II 2G Ex d IIC T4 Gb IP55 Tamb -10°C to +55°C.**

As standard, the motors are supplied in explosion-proof version (Ex d), IP55 degree of protection, B35 configuration for eSHS and B3 for eSHF, IE2 efficiency and fixed speed.; however other options are available. The available options are listed below:

- **Motor efficiency**
 - IE2: standard version
 - IE3: optional version
- **Ex Grade**
 - Ex d : Ex. Proof as standard
 - Ex de: Ex. proof with extra safety on terminal box on request
- **Supplier**
 - CEMP as standard brand
 - Other brand requested
- **Protection Grade**
 - standard IP55: protected against dust and protected water projected from a nozzle
 - optional IP65: dust-tight and protected against water projected from a nozzle
- **Sensors**
 - PTC Optional for fixed speed motors
 - PTC Standard for variable speed motors

ESHS SERIES - ATEX VERSION THREE-PHASE MOTORS AT 50 Hz, 2 POLES

P _N kW	Efficiency η_N (%)															IE		
	Δ 220 V - Y 380 V			Δ 230 V - Y 400 V			Δ 240 V - Y 415 V			Δ 380 V - Y 660 V			Δ 400 V - Y 690 V				Δ 415 V	
	4/4	3/4	2/4	4/4	3/4	2/4	4/4	3/4	2/4	4/4	3/4	2/4	4/4	3/4	2/4	4/4	3/4	2/4
1,1	79,6	79,4	77,0	79,6	79,4	77,0	79,6	79,4	77,0	79,6	79,4	77,0	79,6	79,4	77,0	79,6	79,4	77,0
1,5	81,3	81,5	79,3	81,3	81,5	79,3	81,3	81,5	79,3	81,3	81,5	79,3	81,3	81,5	79,3	81,3	81,5	79,3
2,2	83,2	83,1	80,9	83,2	83,1	80,9	83,2	83,1	80,9	83,2	83,1	80,9	83,2	83,1	80,9	83,2	83,1	80,9
3	84,6	84,1	80,9	84,6	84,1	80,9	84,6	84,1	80,9	84,6	84,1	80,9	84,6	84,1	80,9	84,6	84,1	80,9
4	85,8	86,1	85,2	85,8	86,1	85,2	85,8	86,1	85,2	85,8	86,1	85,2	85,8	86,1	85,2	85,8	86,1	85,2
5,5	87,0	86,4	83,8	87,0	86,4	83,8	87,0	86,4	83,8	87,0	86,4	83,8	87,0	86,4	83,8	87,0	86,4	83,8
7,5	88,1	88,5	85,4	88,1	88,5	85,4	88,1	88,5	85,4	88,1	88,5	85,4	88,1	88,5	85,4	88,1	88,5	85,4
11	89,4	89,2	87,5	89,4	89,2	87,5	89,4	89,2	87,5	89,4	89,2	87,5	89,4	89,2	87,5	89,4	89,2	87,5
15	90,3	90,1	88,5	90,3	90,1	88,5	90,3	90,1	88,5	90,3	90,1	88,5	90,3	90,1	88,5	90,3	90,1	88,5
18,5	90,9	90,9	89,9	90,9	90,9	89,9	90,9	90,9	89,9	90,9	90,9	89,9	90,9	90,9	89,9	90,9	90,9	89,9
22	91,3	89,0	83,2	91,3	89,0	83,2	91,3	89,0	83,2	91,3	89,0	83,2	91,3	89,0	83,2	91,3	89,0	83,2
30	92,0	91,6	89,8	92,0	91,6	89,8	92,0	91,6	89,8	92,0	91,6	89,8	92,0	91,6	89,8	92,0	91,6	89,8

P _N kW	Manufacturer		IEC SIZE	Construction Design	N. of poles	Data for 400 V / 50 Hz Voltage				
	CEMP	Model				cos ϕ	I _s / I _N	T _N Nm	T _s /T _N	T _m /T _N
1,1	AC30r	80B 2	80	B35	2	0,80	5,80	3,71	3,65	2,50
1,5	AC30r	90S 2	90			0,81	6,40	4,97	2,70	2,60
2,2	AC30r	90L 2	90			0,80	7,10	7,29	3,20	4,00
3	AC30r	100LA 2	100			0,79	7,80	9,9	3,20	3,40
4	AC30r	112M 2	112			0,87	7,75	13,2	2,70	3,40
5,5	AC30r	132SA 2	132			0,87	7,20	18,0	2,80	2,90
7,5	AC30r	132SB 2	132			0,85	7,30	24,5	3,00	3,60
11	AC30r	160 MA 2	160			0,89	6,90	35,8	3,40	3,80
15	AC30r	160 MB 2	160			0,90	7,60	48,6	3,40	3,50
18,5	AC30r	160 L 2	160			0,91	5,50	60,2	3,00	3,20
22	AC30r	200 LA 2	200			0,87	6,95	70,6	2,10	2,40
30	AC30r	200 LB2	200			0,93	7,40	96,8	1,70	1,90

P _N kW	Voltage U _N (V)										η_N min ⁻¹	Operating conditions **			
	Δ			Y			Δ			Y		Altitude Above Sea Level (m)	T. amb min/max °C	ATEX	
	220 V	230 V	240 V	380 V	400 V	415 V	380 V	400 V	415 V	660 V	690 V				
1,1	4,64	4,35	3,86	2,68	2,51	2,23	2,68	2,51	2,23	1,55	1,29	2830	≤ 1000	-10 / +55	YES
1,5	5,98	5,72	5,47	3,45	3,30	3,16	3,45	3,30	3,16	1,99	1,82	2880			
2,2	8,68	8,31	7,95	5,01	4,80	4,59	5,01	4,80	4,59	2,89	2,65	2880			
3	11,7	11,2	10,7	6,76	6,47	6,19	6,76	6,47	6,19	3,90	3,57	2905			
4	14,1	13,4	12,9	8,15	7,75	7,46	8,15	7,75	7,46	4,71	4,31	2900			
5,5	19,2	18,2	17,6	11,1	10,5	10,2	11,1	10,5	10,2	6,41	5,87	2920			
7,5	26,3	25,1	23,8	15,2	14,5	13,7	15,2	14,5	13,7	8,76	7,92	2920			
11	36,2	34,5	33,2	20,9	19,9	19,2	20,9	19,9	19,2	12,1	11,1	2935			
15	48,5	46,1	44,4	28,0	26,6	25,6	28,0	26,6	25,6	16,2	14,8	2945			
18,5	58,8	55,9	53,9	34,0	32,3	31,1	34,0	32,3	31,1	19,6	18,0	2930			
22	73,2	69,6	67,1	42,3	40,2	38,7	42,3	40,2	38,7	24,4	22,4	2980			
30	92,7	88,2	85,0	53,5	50,9	49,1	53,5	50,9	49,1	30,9	28,3	2960			

** Operating conditions to be referred to motor only. About electric pump, refer to limits in user's manual.

ESHS-mott-ATEX-2p50-en_a_te

Observe the regulations and codes locally in force regarding sorted waste disposal.

ESHS SERIES - ATEX VERSION THREE-PHASE MOTORS AT 50 Hz, 4 POLES

P _N kW	Efficiency η_N (%)																		IE
	Δ 220 V - Y 380 V			Δ 230 V - Y 400 V			Δ 240 V - Y 415 V			Δ 380 V - Y 660 V			Δ 400 V - Y 690 V			Δ 415 V			
	4/4	3/4	2/4	4/4	3/4	2/4	4/4	3/4	2/4	4/4	3/4	2/4	4/4	3/4	2/4	4/4	3/4	2/4	
0,75	79,6	79,3	76,2	79,6	79,3	76,2	79,6	79,3	76,2	79,6	79,3	76,2	79,6	79,3	76,2	79,6	79,3	76,2	2
1,1	81,4	82,0	80,6	81,4	82,0	80,6	81,4	82,0	80,6	81,4	82,0	80,6	81,4	82,0	80,6	81,4	82,0	80,6	
1,5	82,8	82,2	79,4	82,8	82,2	79,4	82,8	82,2	79,4	82,8	82,2	79,4	82,8	82,2	79,4	82,8	82,2	79,4	
2,2	84,3	83,4	80,3	84,3	83,4	80,3	84,3	83,4	80,3	84,3	83,4	80,3	84,3	83,4	80,3	84,3	83,4	80,3	
3	85,5	85,2	80,1	85,5	85,2	80,1	85,5	85,2	80,1	85,5	85,2	80,1	85,5	85,2	80,1	85,5	85,2	80,1	
4	86,6	86,4	84,2	86,6	86,4	84,2	86,6	86,4	84,2	86,6	86,4	84,2	86,6	86,4	84,2	86,6	86,4	84,2	
5,5	87,7	88,3	87,2	87,7	88,3	87,2	87,7	88,3	87,2	87,7	88,3	87,2	87,7	88,3	87,2	87,7	88,3	87,2	
7,5	88,7	89,5	88,9	88,7	89,5	88,9	88,7	89,5	88,9	88,7	89,5	88,9	88,7	89,5	88,9	88,7	89,5	88,9	
11	89,8	89,5	87,4	89,8	89,5	87,4	89,8	89,5	87,4	89,8	89,5	87,4	89,8	89,5	87,4	89,8	89,5	87,4	

P _N kW	Manufacturer		IEC SIZE	Construction Design	N. of poles	Data for 400 V / 50 Hz Voltage				
	CEMP					cos ϕ	Is / I _N	T _N Nm	Ts/T _N	Tm/T _N
	Model									
0,75	AC30r 80 B 4		80	B35	4	0,67	5,40	5,01	3,00	3,20
1,1	AC30r 90 S 4		90			0,73	5,80	7,34	3,30	3,60
1,5	AC30r 90 L 4		90			0,72	6,40	10,02	3,70	4,40
2,2	AC30r 100 LA 4		100			0,72	7,10	14,47	2,50	3,10
3	AC30r 100 LB 4		100			0,76	6,60	19,98	3,00	3,30
4	AC30r 112 M 4		112			0,76	7,40	26,35	3,50	4,00
5,5	AC30r 132 SB 4		132			0,78	5,10	36,37	2,30	3,00
7,5	AC30r 132 MB 4		132			0,83	5,90	49,59	3,10	3,40
11	AC30r 160 MB 4		160			0,77	6,00	71,57	2,30	3,00

P _N kW	Voltage U _N (V)											η_N min ⁻¹	Operating conditions **		
	Δ			Y			Δ			Y			Altitude Above Sea Level (m)	T. amb min/max °C	ATEX
	220 V	230 V	240 V	380 V	400 V	415 V	380 V	400 V	415 V	660 V	690 V				
	I _N (A)														
0,75	3,74	3,53	3,39	2,16	2,04	1,96	2,16	2,04	1,96	1,25	1,18	1430	≤ 1000	-10 / +55	YES
1,1	4,90	4,64	4,47	2,83	2,68	2,58	2,83	2,68	2,58	1,63	1,55	1430			
1,5	6,60	6,29	6,03	3,81	3,63	3,48	3,81	3,63	3,48	2,20	2,10	1430			
2,2	9,54	9,04	8,71	5,51	5,22	5,03	5,51	5,22	5,03	3,18	3,01	1450			
3	12,1	11,6	11,0	6,96	6,67	6,33	6,96	6,67	6,33	4,02	3,85	1450			
4	16,1	15,3	14,6	9,28	8,82	8,43	9,28	8,82	8,43	5,36	5,09	1435			
5,5	21,3	20,2	19,5	12,3	11,7	11,3	12,3	11,7	11,3	7,10	6,74	1450			
7,5	29,2	25,3	24,4	16,9	14,6	14,1	16,9	14,6	14,1	9,75	8,45	1444			
11	41,8	40,0	31,5	24,1	23,1	18,2	24,1	23,1	18,2	13,9	13,3	1444			

** Operating conditions to be referred to motor only. About electric pump, refer to limits in user's manual.

ESHS-mott-ATEX-4p50-en_a_te

Observe the regulations and codes locally in force regarding sorted waste disposal.

ESHS SERIES - ATEX VERSION THREE-PHASE MOTORS AT 60 Hz, 2 POLES

P _N kW	Efficiency η_N (%)												IE
	Δ 220 V - Y 380 V			Δ 230 V - Y 400 V			Δ 380 V - Y 660 V			Δ 400 V - Y 690 V			
	4/4	3/4	2/4	4/4	3/4	2/4	4/4	3/4	2/4	4/4	3/4	2/4	
1,1	82,5	78,5	71,3	82,5	78,5	71,3	82,5	78,5	71,3	82,5	78,5	71,3	2
1,5	84,0	82,0	77,6	84,0	82,0	77,6	84,0	82,0	77,6	84,0	82,0	77,6	
2,2	85,5	85,4	83,5	85,5	85,4	83,5	85,5	85,4	83,5	85,5	85,4	83,5	
3	87,5	86,6	83,5	87,5	86,6	83,5	87,5	86,6	83,5	87,5	86,6	83,5	
4	87,5	87,3	85,1	87,5	87,3	85,1	87,5	87,3	85,1	87,5	87,3	85,1	
5,5	88,5	87,9	85,4	88,5	87,9	85,4	88,5	87,9	85,4	88,5	87,9	85,4	
7,5	89,5	88,8	86,0	89,5	88,8	86,0	89,5	88,8	86,0	89,5	88,8	86,0	
11	90,2	89,1	85,5	90,2	89,1	85,5	90,2	89,1	85,5	90,2	89,1	85,5	
15	90,2	89,6	86,8	90,2	89,6	86,8	90,2	89,6	86,8	90,2	89,6	86,8	
18,5	91,0	90,3	88,2	91,0	90,3	88,2	91,0	90,3	88,2	91,0	90,3	88,2	
22	91,0	89,8	86,7	91,0	89,8	86,7	91,0	89,8	86,7	91,0	89,8	86,7	
30	91,7	90,9	87,7	91,7	90,9	87,7	91,7	90,9	87,7	91,7	90,9	87,7	

P _N kW	Manufacturer		IEC SIZE	Construction Design	N. of poles	Data for 380 V / 60 Hz Voltage				
	CEMP	Model				cos ϕ	Is / I _N	T _N Nm	Ts/T _N	Tm/T _N
1,1	AC30r	80B 2	80	B35	2	0,75	6,00	3,06	3,80	3,90
1,5	AC30r	90L 2	90			0,70	7,55	4,08	5,10	5,20
2,2	AC30r	90L 2	90			0,87	7,00	6,04	2,10	2,50
3	AC30r	100LA 2	100			0,81	5,84	8,23	2,40	2,70
4	AC30r	112M 2	112			0,86	8,85	10,90	3,00	3,20
5,5	AC30r	132SA 2	132			0,87	5,95	15,00	2,20	2,50
7,5	AC30r	132MB 2	160			0,84	8,00	20,30	3,10	3,40
11	AC30r	160MB 2	160			0,88	8,18	29,55	2,90	3,20
15	AC30r	160MB 2	160			0,90	8,18	40,40	3,50	3,70
18,5	AC30r	160L 2	160			0,91	9,00	49,70	2,20	2,60
22	AC30r	200LA 2	200			0,86	7,90	58,70	3,20	3,45
30	AC30r	200LB 2	200			0,90	7,00	80,11	2,50	2,60

P _N kW	Voltage U _N (V)								n _N min ⁻¹	Operating conditions **		
	Δ		Y		Δ		Y			Altitude Above Sea Level (m)	T. amb min/max °C	ATEX
	220 V	230 V	380 V	400 V	380 V	400 V	660 V	690 V				
	I _N (A)											
1,1	4,71	4,47	2,72	2,58	2,72	2,58	1,57	1,49	3432	≤ 1000	-10/+55	YES
1,5	6,71	6,38	3,88	3,69	3,88	3,69	2,24	2,13	3515			
2,2	7,74	7,35	4,47	4,25	4,47	4,25	2,59	2,46	3476			
3	11,2	10,6	6,47	6,15	6,47	6,15	3,74	3,55	3482			
4	14,0	13,3	8,12	7,71	8,12	7,71	4,69	4,46	3506			
5,5	18,8	17,9	10,9	10,4	10,9	10,4	6,30	5,98	3505			
7,5	26,2	24,9	15,1	14,4	15,1	14,4	8,74	8,31	3528			
11	36,5	34,7	21,1	20,1	21,1	20,1	12,2	11,6	3555			
15	48,8	46,3	28,2	26,8	28,2	26,8	16,3	15,5	3546			
18,5	59,0	56,1	34,1	32,4	34,1	32,4	19,7	18,7	3555			
22	73,9	70,2	42,7	40,6	42,7	40,6	24,7	23,5	3579			
30	96,1	91,3	55,6	52,8	55,6	52,8	32,1	30,5	3576			

** Operating conditions to be referred to motor only. About electric pump, refer to limits in user's manual.

ESHS-mott-ATEX-2p60-en_a_te

Observe the regulations and codes locally in force regarding sorted waste disposal.

ESHS SERIES - ATEX VERSION THREE-PHASE MOTORS AT 60 Hz, 4 POLES

P _N kW	Efficiency η_N (%)												IE
	Δ 220 V - Y 380 V			Δ 230 V - Y 400 V			Δ 380 V - Y 660 V			Δ 400 V - Y 690 V			
	4/4	3/4	2/4	4/4	3/4	2/4	4/4	3/4	2/4	4/4	3/4	2/4	
0,75	80,0	79,7	77,8	80,0	79,7	77,8	80,0	79,7	77,8	80,0	79,7	77,8	2
1,1	84,0	83,2	77,0	84,0	83,2	77,0	84,0	83,2	77,0	84,0	83,2	77,0	
1,5	84,0	83,3	80,5	84,0	83,3	80,5	84,0	83,3	80,5	84,0	83,3	80,5	
2,2	87,5	87,7	85,0	87,5	87,7	85,0	87,5	87,7	85,0	87,5	87,7	85,0	
3	87,5	87,7	85,0	87,5	87,7	85,0	87,5	87,7	85,0	87,5	87,7	85,0	
4	87,5	87,4	85,4	87,5	87,4	85,4	87,5	87,4	85,4	87,5	87,4	85,4	
5,5	89,5	88,6	85,2	89,5	88,6	85,2	89,5	88,6	85,2	89,5	88,6	85,2	
7,5	89,5	89,2	87,3	89,5	89,2	87,3	89,5	89,2	87,3	89,5	89,2	87,3	
11	91,0	90,0	86,8	91,0	90,0	86,8	91,0	90,0	86,8	91,0	90,0	86,8	

P _N kW	Manufacturer		IEC SIZE	Construction Design	N. of poles	Data for 380 V / 60 Hz Voltage				
	CEMP	Model				cos ϕ	I _s / I _N	T _N Nm	T _s /T _N	T _m /T _N
0,75	AC30r 80B 4		80	B35	4	0,67	5,20	4,16	2,70	2,90
1,1	AC30r 90L 4		90			0,73	5,00	6,14	2,20	2,40
1,5	AC30r 90L 4		90			0,72	6,50	8,28	2,60	2,90
2,2	AC30r 100LA 4		100			0,71	5,75	12,05	3,00	3,30
3	AC30r 100LB 4		100			0,77	5,62	16,57	1,90	2,30
4	AC30r 112M 4		112			0,78	6,96	21,95	2,60	2,90
5,5	AC30r 132MB 4		132			0,70	8,04	29,87	3,80	4,00
7,5	AC30r 132MB 4		132			0,75	7,78	40,98	3,40	3,70
11	AC30r 160L 4		160			0,75	7,13	59,26	2,95	3,30

P _N kW	Voltage U _N (V)								n _N min ⁻¹	Operating conditions **		
	Δ		Y		Δ		Y			Altitude Above Sea Level (m)	T. amb min/max °C	ATEX
	220 V	230 V	380 V	400 V	380 V	400 V	660 V	690 V				
	I _N (A)											
0,75	3,67	3,48	2,12	2,01	2,12	2,01	1,23	1,16	1724	≤ 1000	-10 / +55	YES
1,1	4,73	4,50	2,74	2,60	2,74	2,60	1,58	1,50	1712			
1,5	6,52	6,19	3,77	3,58	3,77	3,58	2,18	2,07	1730			
2,2	9,53	9,06	5,51	5,23	5,51	5,23	3,18	3,03	1743			
3	11,6	11,1	6,73	6,39	6,73	6,39	3,89	3,70	1729			
4	15,5	14,7	8,95	8,50	8,95	8,50	5,17	4,91	1740			
5,5	23,0	21,9	13,3	12,6	13,3	12,6	7,69	7,30	1758			
7,5	29,2	27,7	16,9	16,0	16,9	16,0	9,76	9,27	1748			
11	42,21	40,10	24,4	23,2	24,4	23,2	14,1	13,4	1773			

** Operating conditions to be referred to motor only. About electric pump, refer to limits in user's manual.

ESHS-mott-ATEX-4p60-en_a_te

Observe the regulations and codes locally in force regarding sorted waste disposal.

ESHF SERIES - ATEX VERSION THREE-PHASE MOTORS AT 50 Hz, 2 POLES

P _N kW	Efficiency η _N (%)																		IE
	Δ 220 V - Y 380 V			Δ 230 V - Y 400 V			Δ 240 V - Y 415 V			Δ 380 V - Y 660 V			Δ 400 V - Y 690 V			Δ 415 V			
	4/4	3/4	2/4	4/4	3/4	2/4	4/4	3/4	2/4	4/4	3/4	2/4	4/4	3/4	2/4	4/4	3/4	2/4	
1,10	79,6	79,4	77,0	79,6	79,4	77,0	79,6	79,4	77,0	79,6	79,4	77,0	79,6	79,4	77,0	79,6	79,4	77,0	2
1,5	81,3	81,5	79,3	81,3	81,5	79,3	81,3	81,5	79,3	81,3	81,5	79,3	81,3	81,5	79,3	81,3	81,5	79,3	
2,2	83,2	83,1	80,9	83,2	83,1	80,9	83,2	83,1	80,9	83,2	83,1	80,9	83,2	83,1	80,9	83,2	83,1	80,9	
3	84,6	84,1	80,9	84,6	84,1	80,9	84,6	84,1	80,9	84,6	84,1	80,9	84,6	84,1	80,9	84,6	84,1	80,9	
4	85,8	86,1	85,2	85,8	86,1	85,2	85,8	86,1	85,2	85,8	86,1	85,2	85,8	86,1	85,2	85,8	86,1	85,2	
5,5	87,0	86,4	83,8	87,0	86,4	83,8	87,0	86,4	83,8	87,0	86,4	83,8	87,0	86,4	83,8	87,0	86,4	83,8	
7,5	88,1	88,5	85,4	88,1	88,5	85,4	88,1	88,5	85,4	88,1	88,5	85,4	88,1	88,5	85,4	88,1	88,5	85,4	
11	89,4	89,2	87,5	89,4	89,2	87,5	89,4	89,2	87,5	89,4	89,2	87,5	89,4	89,2	87,5	89,4	89,2	87,5	
15	90,3	90,1	88,5	90,3	90,1	88,5	90,3	90,1	88,5	90,3	90,1	88,5	90,3	90,1	88,5	90,3	90,1	88,5	
18,5	90,9	90,9	89,9	90,9	90,9	89,9	90,9	90,9	89,9	90,9	90,9	89,9	90,9	90,9	89,9	90,9	90,9	89,9	
22	91,3	89,0	83,2	91,3	89,0	83,2	91,3	89,0	83,2	91,3	89,0	83,2	91,3	89,0	83,2	91,3	89,0	83,2	
30	92,0	91,6	89,8	92,0	91,6	89,8	92,0	91,6	89,8	92,0	91,6	89,8	92,0	91,6	89,8	92,0	91,6	89,8	
37	92,8	92,1	89,9	92,8	92,1	89,9	92,8	92,1	89,9	92,8	92,1	89,9	92,8	92,1	89,9	92,8	92,1	89,9	
45	92,9	92,1	90,1	92,9	92,1	90,1	92,9	92,1	90,1	92,9	92,1	90,1	92,9	92,1	90,1	92,9	92,1	90,1	
55	94,1	93,7	92,1	94,1	93,7	92,1	94,1	93,7	92,1	94,1	93,7	92,1	94,1	93,7	92,1	94,1	93,7	92,1	
75	93,8	92,0	89,2	93,8	92,0	89,2	93,8	92,0	89,2	93,8	92,0	89,2	93,8	92,0	89,2	93,8	92,0	89,2	

P _N kW	Manufacturer		IEC SIZE	Constructio n Design	N. of poles	Data for 400 V / 50 Hz Voltage				
	CEMP	Model				cosφ	Is / I _N	T _N Nm	Ts/T _N	Tm/T _N
1,1	AC30r	80B 2	80	B3	2	0,80	5,80	3,71	3,65	2,50
1,5	AC30r	90S 2	90			0,81	6,40	4,97	2,70	2,60
2,2	AC30r	90L 2	90			0,80	7,10	7,29	3,20	4,00
3	AC30r	100LA 2	100			0,79	7,80	9,85	3,20	3,40
4	AC30r	112M 2	112			0,87	7,75	13,2	2,70	3,40
5,5	AC30r	132SA 2	132			0,87	7,20	18,0	2,80	2,90
7,5	AC30r	132SB 2	132			0,85	7,30	24,5	3,00	3,60
11	AC30r	160 MA 2	160			0,89	6,90	35,8	3,40	3,80
15	AC30r	160 MB 2	160			0,90	7,60	48,6	3,40	3,50
18,5	AC30r	160 L 2	160			0,91	5,50	60,2	3,00	3,20
22	AC30r	200 LA 2	200			0,87	6,95	70,6	2,10	2,40
30	AC30r	200 LB2	200			0,93	7,40	96,8	1,70	1,90
37	AC30r	225 M 2	225			0,92	8,00	120,0	2,00	2,30
45	AC30r	250 M 2	250			0,90	7,90	144,5	2,30	2,50
55	AC30r	280 S 2	280			0,89	9,10	176,2	2,40	2,70
75	AC30r	280 M 2	280			0,88	6,80	240,1	2,10	2,40

P _N kW	Voltage U _N (V)										η _N min ⁻¹	Operating conditions **			
	Δ			Y			Δ			Y		Altitude Above Sea Level (m)	T. amb min/max °C	ATEX	
	220 V	230 V	240 V	380 V	400 V	415 V	380 V	400 V	415 V	660 V	690 V				
1,1	4,64	4,35	3,86	2,68	2,51	2,23	2,68	2,51	2,23	1,55	1,29	2830	≤ 1000	-10 / +55	YES
1,5	5,98	5,72	5,47	3,45	3,30	3,16	3,45	3,30	3,16	1,99	1,82	2880			
2,2	8,68	8,31	7,95	5,01	4,80	4,59	5,01	4,80	4,59	2,89	2,65	2880			
3	11,7	11,2	10,7	6,76	6,47	6,19	6,76	6,47	6,19	3,90	3,57	2905			
4	14,1	13,4	12,9	8,15	7,75	7,46	8,15	7,75	7,46	4,71	4,31	2900			
5,5	19,2	18,2	17,6	11,1	10,5	10,2	11,1	10,5	10,2	6,41	5,87	2920			
7,5	26,3	25,1	23,8	15,2	14,5	13,7	15,2	14,5	13,7	8,76	7,92	2920			
11	36,2	34,5	33,2	20,9	19,9	19,2	20,9	19,9	19,2	12,1	11,1	2935			
15	48,5	46,1	44,4	28,0	26,6	25,6	28,0	26,6	25,6	16,2	14,8	2945			
18,5	58,8	55,9	53,9	34,0	32,3	31,1	34,0	32,3	31,1	19,6	18,0	2930			
22	73,2	69,6	67,1	42,3	40,2	38,7	42,3	40,2	38,7	24,4	22,4	2980			
30	92,7	88,2	85,0	53,5	50,9	49,1	53,5	50,9	49,1	30,9	28,3	2960			
37	114	109	105	66,0	62,7	60,4	66,0	62,7	60,4	38,1	34,9	2975			
45	143	135	131	82,3	78,2	75,4	82,3	78,2	75,4	47,5	43,5	2975			
55	173	164	158	99,7	94,7	91,3	99,7	94,7	91,3	57,6	52,7	2980			
75	239	227	219	138	131	126	138	131	126	79,6	72,9	2983			

** Operating conditions to be referred to motor only. About electric pump, refer to limits in user's manual.
Observe the regulations and codes locally in force regarding sorted waste disposal.

ESHF SERIES - ATEX VERSION THREE-PHASE MOTORS AT 50 Hz, 4 POLES

P _N kW	Efficiency η_N (%)																		IE
	Δ 220 V - Y 380 V			Δ 230 V - Y 400 V			Δ 240 V - Y 415 V			Δ 380 V - Y 660 V			Δ 400 V - Y 690 V			Δ 415 V			
	4/4	3/4	2/4	4/4	3/4	2/4	4/4	3/4	2/4	4/4	3/4	2/4	4/4	3/4	2/4	4/4	3/4	2/4	
0,25	60,0	59,0	53,0	60,0	59,0	53,0	60,0	59,0	53,0	60,0	59,0	53,0	60,0	59,0	53,0	60,0	59,0	53,0	1
0,37	69,0	68,4	64,0	69,0	68,4	64,0	69,0	68,4	64,0	69,0	68,4	64,0	69,0	68,4	64,0	69,0	68,4	64,0	
0,55	69,0	67,0	62,0	69,0	67,0	62,0	69,0	67,0	62,0	69,0	67,0	62,0	69,0	67,0	62,0	69,0	67,0	62,0	
0,75	79,6	79,3	76,2	79,6	79,3	76,2	79,6	79,3	76,2	79,6	79,3	76,2	79,6	79,3	76,2	79,6	79,3	76,2	2
1,1	81,4	82,0	80,6	81,4	82,0	80,6	81,4	82,0	80,6	81,4	82,0	80,6	81,4	82,0	80,6	81,4	82,0	80,6	
1,5	82,8	82,2	79,4	82,8	82,2	79,4	82,8	82,2	79,4	82,8	82,2	79,4	82,8	82,2	79,4	82,8	82,2	79,4	
2,2	84,3	83,4	80,3	84,3	83,4	80,3	84,3	83,4	80,3	84,3	83,4	80,3	84,3	83,4	80,3	84,3	83,4	80,3	
3	85,5	85,2	80,1	85,5	85,2	80,1	85,5	85,2	80,1	85,5	85,2	80,1	85,5	85,2	80,1	85,5	85,2	80,1	
4	86,6	86,4	84,2	86,6	86,4	84,2	86,6	86,4	84,2	86,6	86,4	84,2	86,6	86,4	84,2	86,6	86,4	84,2	
5,5	87,7	88,3	87,2	87,7	88,3	87,2	87,7	88,3	87,2	87,7	88,3	87,2	87,7	88,3	87,2	87,7	88,3	87,2	
7,5	88,7	89,5	88,9	88,7	89,5	88,9	88,7	89,5	88,9	88,7	89,5	88,9	88,7	89,5	88,9	88,7	89,5	88,9	
11	89,8	89,5	87,4	89,8	89,5	87,4	89,8	89,5	87,4	89,8	89,5	87,4	89,8	89,5	87,4	89,8	89,5	87,4	

P _N kW	Manufacturer		IEC SIZE	Construction Design	N. of poles	Data for 400 V / 50 Hz Voltage				
	CEMP	Model				cos ϕ	Is / I _N	T _N Nm	Ts/T _N	Tm/T _N
0,25	AC30r	71 A 4	71	B3	4	0,74	3,00	1,72	2,20	2,60
0,37	AC30r	71 B 4	71			0,72	3,50	2,53	2,20	2,76
0,55	AC30r	80 A 4	80			0,71	4,00	3,86	2,30	2,50
0,75	AC30r	80 B 4	80			0,67	5,40	5,01	3,00	3,20
1,1	AC30r	90 S 4	90			0,73	5,80	7,34	3,30	3,60
1,5	AC30r	90 L 4	90			0,72	6,40	10,02	3,70	4,40
2,2	AC30r	100 LA 4	100			0,72	7,10	14,47	2,50	3,10
3	AC30r	100 LB 4	100			0,76	6,60	19,98	3,00	3,30
4	AC30r	112 M 4	112			0,76	7,40	26,35	3,50	4,00
5,5	AC30r	132 SB 4	132			0,78	5,10	36,37	2,30	3,00
7,5	AC30r	132 MB 4	132			0,83	5,90	49,59	3,10	3,40
11	AC30r	160 MB 4	160			0,77	6,00	71,6	2,30	3,00

P _N kW	Voltage U _N (V)											η_N min ⁻¹	Operating conditions **		
	Δ			Y			Δ			Y			Altitude Above Sea Level (m)	T. amb min/max °C	ATEX
	220 V	230 V	240 V	380 V	400 V	415 V	380 V	400 V	415 V	660 V	690 V				
	I _N (A)														
0,25	1,45	1,38	1,33	0,84	0,80	0,77	0,84	0,80	0,77	0,48	0,46	1372	≤ 1000	-10 / +55	YES
0,37	1,95	1,87	1,79	1,14	1,08	1,04	1,14	1,08	1,04	0,65	0,62	1390			
0,55	2,98	2,85	2,74	1,74	1,65	1,59	1,74	1,65	1,59	1,00	0,95	1380			
0,75	3,74	3,53	3,39	2,16	2,04	1,96	2,16	2,04	1,96	1,25	1,18	1430			
1,1	4,90	4,64	4,47	2,83	2,68	2,58	2,83	2,68	2,58	1,63	1,55	1430			
1,5	6,60	6,29	6,03	3,81	3,63	3,48	3,81	3,63	3,48	2,20	2,10	1430			
2,2	9,54	9,04	8,71	5,51	5,22	5,03	5,51	5,22	5,03	3,18	3,01	1450			
3	12,1	11,6	11,0	6,96	6,67	6,33	6,96	6,67	6,33	4,02	3,85	1450			
4	16,1	15,3	14,6	9,28	8,82	8,43	9,28	8,82	8,43	5,36	5,09	1435			
5,5	21,3	20,2	19,5	12,3	11,7	11,3	12,3	11,7	11,3	7,10	6,74	1450			
7,5	29,2	25,3	24,4	16,9	14,6	14,1	16,9	14,6	14,1	9,75	8,45	1444			
11	41,8	40,0	31,5	24,1	23,1	18,2	24,1	23,1	18,2	13,9	13,3	1444			

** Operating conditions to be referred to motor only. About electric pump, refer to limits in user's manual.

ESHF-mott-ATEX-4p50-en_a_te

Observe the regulations and codes locally in force regarding sorted waste disposal.

ESHF SERIES - ATEX VERSION THREE-PHASE MOTORS AT 60 Hz, 2 POLES

P _N kW	Efficiency η_N (%)												IE
	Δ 220 V - Y 380 V			Δ 230 V - Y 400 V			Δ 380 V - Y 660 V			Δ 400 V - Y 690 V			
	4/4	3/4	2/4	4/4	3/4	2/4	4/4	3/4	2/4	4/4	3/4	2/4	
1,1	82,5	78,5	71,3	82,5	78,5	71,3	82,5	78,5	71,3	82,5	78,5	71,3	2
1,5	84,0	82,0	77,6	84,0	82,0	77,6	84,0	82,0	77,6	84,0	82,0	77,6	
2,2	85,5	85,4	83,5	85,5	85,4	83,5	85,5	85,4	83,5	85,5	85,4	83,5	
3	87,5	86,6	83,5	87,5	86,6	83,5	87,5	86,6	83,5	87,5	86,6	83,5	
4	87,5	87,3	85,1	87,5	87,3	85,1	87,5	87,3	85,1	87,5	87,3	85,1	
5,5	88,5	87,9	85,4	88,5	87,9	85,4	88,5	87,9	85,4	88,5	87,9	85,4	
7,5	89,5	88,8	86,0	89,5	88,8	86,0	89,5	88,8	86,0	89,5	88,8	86,0	
11	90,2	89,1	85,5	90,2	89,1	85,5	90,2	89,1	85,5	90,2	89,1	85,5	
15	90,2	89,6	86,8	90,2	89,6	86,8	90,2	89,6	86,8	90,2	89,6	86,8	
18,5	91,0	90,3	88,2	91,0	90,3	88,2	91,0	90,3	88,2	91,0	90,3	88,2	
22	91,0	89,8	86,7	91,0	89,8	86,7	91,0	89,8	86,7	91,0	89,8	86,7	
30	91,7	90,9	87,7	91,7	90,9	87,7	91,7	90,9	87,7	91,7	90,9	87,7	
37	92,4	90,8	87,5	92,4	90,8	87,5	92,4	90,8	87,5	92,4	90,8	87,5	
45	93,0	92,0	89,3	93,0	92,0	89,3	93,0	92,0	89,3	93,0	92,0	89,3	
55	93,0	91,0	86,3	93,0	91,0	86,3	93,0	91,0	86,3	93,0	91,0	86,3	
75	93,6	92,6	84,2	93,6	92,6	84,2	93,6	92,6	84,2	93,6	92,6	84,2	

P _N kW	Manufacturer		IEC SIZE	Construction Design	N. of poles	Data for 380 V / 60 Hz Voltage				
	CEMP					cos ϕ	I _s / I _N	T _N Nm	T _s /T _N	T _m /T _N
	Model									
1,1	AC30r 80B 2		80	B3	2	0,75	6,00	3,06	3,80	3,90
1,5	AC30r 90L 2		90			0,70	7,55	4,08	5,10	5,20
2,2	AC30r 90L 2		90			0,87	7,00	6,04	2,10	2,50
3	AC30r 100LA 2		100			0,81	5,84	8,23	2,40	2,70
4	AC30r 112M 2		112			0,86	8,85	10,90	3,00	3,20
5,5	AC30r 132SA 2		132			0,87	5,95	15,00	2,20	2,50
7,5	AC30r 132MB 2		160			0,84	8,00	20,30	3,10	3,40
11	AC30r 160MB 2		160			0,88	8,18	29,55	2,90	3,20
15	AC30r 160MB 2		160			0,90	8,18	40,40	3,50	3,70
18,5	AC30r 160L 2		160			0,91	9,00	49,70	2,20	2,60
22	AC30r 200LA 2		200			0,86	7,90	58,70	3,20	3,45
30	AC30r 200LB 2		200			0,90	7,00	80,11	2,50	2,60
37	AC30r 225M 2		225			0,88	8,00	98,81	2,20	2,60
45	AC30r 250M 2		250			0,90	7,00	120,10	2,20	2,40
55	AC30r 280S 2		280			0,86	7,10	146,60	2,50	3,10
75	AC30r 280M 2		280			0,87	8,00	199,85	2,60	2,90

P _N kW	Voltage U _N (V)								n _N min ⁻¹	Operating conditions **		
	Δ		Y		Δ		Y			Altitude Above Sea Level (m)	T. amb min/max °C	ATEX
	220 V	230 V	380 V	400 V	380 V	400 V	660 V	690 V				
1,1	4,71	4,47	2,72	2,58	2,72	2,58	1,57	1,49	3432	≤ 1000	-10/+55	YES
1,5	6,71	6,38	3,88	3,69	3,88	3,69	2,24	2,13	3515			
2,2	7,74	7,35	4,47	4,25	4,47	4,25	2,59	2,46	3476			
3	11,2	10,6	6,47	6,15	6,47	6,15	3,74	3,55	3482			
4	14,0	13,3	8,12	7,71	8,12	7,71	4,69	4,46	3506			
5,5	18,8	17,9	10,9	10,4	10,9	10,4	6,30	5,98	3505			
7,5	26,2	24,9	15,1	14,4	15,1	14,4	8,74	8,31	3528			
11	36,5	34,7	21,1	20,1	21,1	20,1	12,2	11,6	3555			
15	48,8	46,3	28,2	26,8	28,2	26,8	16,3	15,5	3546			
18,5	59,0	56,1	34,1	32,4	34,1	32,4	19,7	18,7	3555			
22	73,9	70,2	42,7	40,6	42,7	40,6	24,7	23,5	3579			
30	96,1	91,3	55,6	52,8	55,6	52,8	32,1	30,5	3576			
37	119	113	69,0	65,6	69,0	65,6	39,9	37,9	3576			
45	142	135	82,1	78,0	82,1	78,0	47,5	45,1	3580			
55	181	172	105	99,5	104,77	99,5	60,6	57,5	3584			
75	243	231	140	133,5	140,5	133,5	81,2	77,1	3584			

** Operating conditions to be referred to motor only. About electric pump, refer to limits in user's manual.

ESHF SERIES - ATEX VERSION THREE-PHASE MOTORS AT 60 Hz, 4 POLES

P _N kW	Efficiency η_N (%)												IE
	Δ 220 V - Y 380 V			Δ 230 V - Y 400 V			Δ 380 V - Y 660 V			Δ 400 V - Y 690 V			
	4/4	3/4	2/4	4/4	3/4	2/4	4/4	3/4	2/4	4/4	3/4	2/4	
0,25	57,6	51,8	42,6	57,6	51,8	42,6	57,6	51,8	42,6	57,6	51,8	42,6	1
0,37	69,0	68,0	64,0	69,0	68,0	64,0	69,0	68,0	64,0	69,0	68,0	64,0	
0,55	69,0	67,0	62,0	69,0	67,0	62,0	69,0	67,0	62,0	69,0	67,0	62,0	
0,75	80,0	79,7	77,8	80,0	79,7	77,8	80,0	79,7	77,8	80,0	79,7	77,8	
1,1	84,0	83,2	77,0	84,0	83,2	77,0	84,0	83,2	77,0	84,0	83,2	77,0	2
1,5	84,0	83,3	80,5	84,0	83,3	80,5	84,0	83,3	80,5	84,0	83,3	80,5	
2,2	87,5	87,7	85,0	87,5	87,7	85,0	87,5	87,7	85,0	87,5	87,7	85,0	
3	87,5	87,7	85,0	87,5	87,7	85,0	87,5	87,7	85,0	87,5	87,7	85,0	
4	87,5	87,4	85,4	87,5	87,4	85,4	87,5	87,4	85,4	87,5	87,4	85,4	
5,5	89,5	88,6	85,2	89,5	88,6	85,2	89,5	88,6	85,2	89,5	88,6	85,2	
7,5	89,5	89,2	87,3	89,5	89,2	87,3	89,5	89,2	87,3	89,5	89,2	87,3	
11	91,0	90,0	86,8	91,0	90,0	86,8	91,0	90,0	86,8	91,0	90,0	86,8	

P _N kW	Manufacturer		IEC SIZE	Construction Design	N. of poles	Data for 380 V / 60 Hz Voltage				
	CEMP					cos ϕ	I _s / I _N	T _N Nm	T _s /T _N	T _m /T _N
	Model									
0,25	AC30r 71 A 4		71	B3	4	0,59	3,40	1,00	3,20	3,50
0,37	AC30r 71 B 4		71			0,72	3,70	2,11	2,20	2,50
0,55	AC30r 80 A 4		80			0,71	3,20	3,17	1,80	2,00
0,75	AC30r 80B 4		80			0,67	5,20	4,16	2,70	2,90
1,1	AC30r 90L 4		90			0,73	5,00	6,14	2,20	2,40
1,5	AC30r 90L 4		90			0,72	6,50	8,28	2,60	2,90
2,2	AC30r 100LA 4		100			0,71	5,75	12,05	3,00	3,30
3	AC30r 100LB 4		100			0,77	5,62	16,57	1,90	2,30
4	AC30r 112M 4		112			0,78	6,96	21,95	2,60	2,90
5,5	AC30r 132MB 4		132			0,70	8,04	29,87	3,80	4,00
7,5	AC30r 132MB 4		132			0,75	7,78	40,98	3,40	3,70
11	AC30r 160L 4		160			0,75	7,13	59,26	2,95	3,30

P _N kW	Voltage U _N (V)								n_N min ⁻¹	Operating conditions **		
	Δ		Y		Δ		Y			Altitude Above Sea Level (m)	T. amb min/max °C	ATEX
	220 V	230 V	380 V	400 V	380 V	400 V	660 V	690 V				
	I _N (A)											
0,25	1,37	1,31	0,80	0,76	0,80	0,76	0,46	0,44	1715	≤ 1000	-10/+55	YES
0,37	1,92	1,83	1,12	1,06	1,12	1,06	0,64	0,61	1668			
0,55	2,95	2,82	1,72	1,63	1,72	1,63	0,99	0,94	1689			
0,75	3,67	3,48	2,12	2,01	2,12	2,01	1,23	1,16	1724			
1,1	4,73	4,50	2,74	2,60	2,74	2,60	1,58	1,50	1712			
1,5	6,52	6,19	3,77	3,58	3,77	3,58	2,18	2,07	1730			
2,2	9,53	9,06	5,51	5,23	5,51	5,23	3,18	3,03	1743			
3	11,6	11,1	6,73	6,39	6,73	6,39	3,89	3,70	1729			
4	15,5	14,7	8,95	8,50	8,95	8,50	5,17	4,91	1740			
5,5	23,0	21,9	13,3	12,6	13,3	12,6	7,69	7,30	1758			
7,5	29,2	27,7	16,9	16,0	16,9	16,0	9,76	9,27	1748			
11	42,2	40,1	24,4	23,2	24,4	23,2	14,1	13,4	1773			

** Operating conditions to be referred to motor only. About electric pump, refer to limits in user's manual.

ESHF-mott-ATEX-4p60-en_a_te

Observe the regulations and codes locally in force regarding sorted waste disposal.

ESH SERIES - ATEX VERSION MOTOR NOISE

The tables below show the mean sound pressure levels (Lp) measured at 1 meter's distance in a free field according to the A curve (ISO 1680 standard).

The noise values are measured with idling motor with a tolerance of 3 dB (A).

ESH MOTORS 2 POLES 50 Hz

POWER	MOTOR TYPE	NOISE
kW	IEC SIZE	LpA dB
0,75	80	62
1,1	80	62
1,5	90	69
2,2	90	69
3	100	72
4	112	72
5,5	132	73
7,5	132	75
11	160	76
15	160	76
18,5	160	76
22	200	77
30	200	77
37	225	79
45	250	79
55	280	76
75	280	76

ESH MOTORS 2 POLES 60 Hz

POWER	MOTOR TYPE	NOISE
kW	IEC SIZE	LpA dB
0,75	80	65
1,1	80	65
1,5	90	72
2,2	90	72
3	100	75
4	112	75
5,5	132	76
7,5	132	78
11	160	79
15	160	79
18,5	160	79
22	200	80
30	200	80
37	225	82
45	250	82
55	280	79
75	280	79

ESH MOTORS 4 POLES 50 Hz

POWER	MOTOR TYPE	NOISE
kW	IEC SIZE	LpA dB
0,75	80	51
1,1	90	54
1,5	90	54
2,2	100	55
3	100	55
4	112	60
5,5	132	64
7,5	132	67
11	160	69

ESH MOTORS 4 POLES 60 Hz

POWER	MOTOR TYPE	NOISE
kW	IEC SIZE	LpA dB
0,75	80	54
1,1	90	57
1,5	90	57
2,2	100	58
3	100	58
4	112	63
5,5	132	67
7,5	132	70
11	160	72

ESH-mott-ATEX-en_a_tr

DIMENSIONS AND WEIGHTS

ESHS SERIES - ATEX VERSION
DIMENSIONS AND WEIGHTS AT 50 Hz, 2 POLES

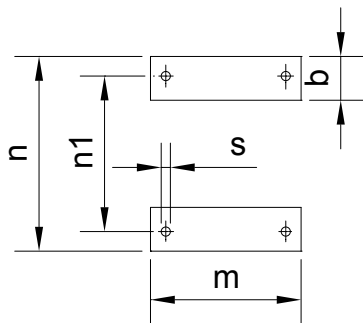
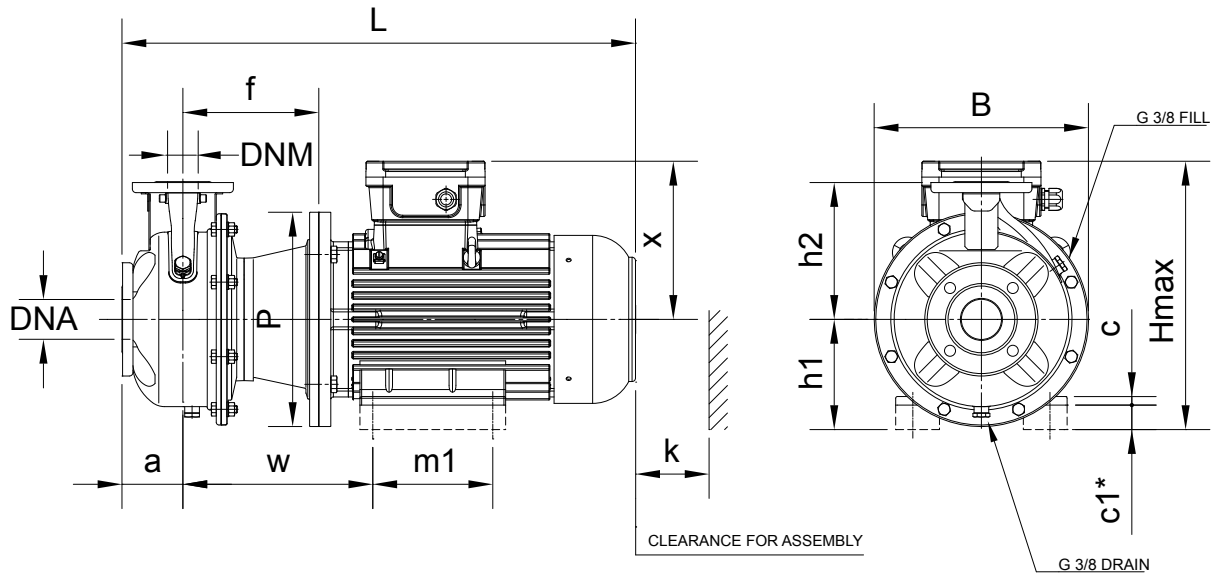

PUMP FLANGES

DN	D	M	G	HOLES		MAX. THICKNESS
				N°	DIA.	
25	115	85	56	4	18	16
32	140	100	64	4	18	16
40	150	110	68	4	18	16
50	165	125	83	4	18	18
65	185	145	104	4	18	18
80	200	160	116	8	18	20
100	225	180	142	8	18	20

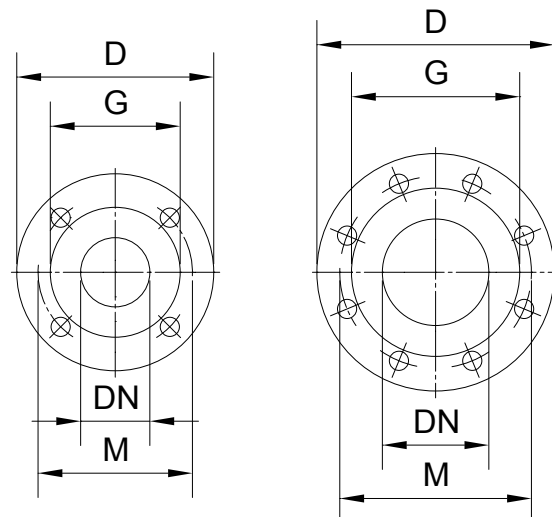

* Minimum motor shims height. Shims supplied as accessories.

ESHS SERIES - ATEX VERSION DIMENSIONS AND WEIGHTS AT 50 Hz, 2 POLES

PUMP TYPE ESHS..2...-EX2	DIMENSIONS (mm)																			B	H max	L	k	WEIGHT kg
	PUMP					MOTOR FEET																		
	DNM	DNA	a	f	h2	w	x	b	c	c1*	h1	P	m	m1	n	n1	s							
25-125/11Y/C	25	50	80	155	140	205	165	40	8	80	160	200	130	100	160	125	9	218	325	522	98	40		
25-125/11/C	25	50	80	155	140	205	165	40	8	80	160	200	130	100	160	125	9	218	325	522	98	41		
25-160/22Y/C	25	50	80	155	160	211	175	45	9	70	160	200	157	125	175	140	9	253	335	575	98	49		
25-160/22/C	25	50	80	155	160	211	175	45	9	70	160	200	157	125	175	140	9	253	335	575	98	44		
25-200/30/C	25	50	80	165	180	228	185	45	10	60	160	250	170	140	200	160	12	284	345	615	98	66		
25-200/40/C	25	50	80	165	180	235	206	45	12	48	160	250	175	140	235	190	12	284	366	660	98	89		
25-250/55/C	25	50	100	192	225	281	260	56	13	48	180	300	222	140	272	216	12	345	440	717	98	135		
25-250/75/C	25	50	100	192	225	281	260	56	13	48	180	300	222	140	272	216	12	345	440	717	98	130		
25-250/110/C	25	50	100	222	225	330	290	64	15	20	180	350	305	210	318	254	14	350	470	905	98	208		
32-125/11Y/C	32	50	80	155	140	205	165	40	8	32	112	200	130	100	160	125	9	218	277	522	98	40		
32-125/11/C	32	50	80	155	140	205	165	40	8	32	112	200	130	100	160	125	9	218	277	522	98	41		
32-160/22Y/C	32	50	80	155	160	211	175	45	9	42	132	200	157	125	175	140	9	253	307	575	98	49		
32-160/22/C	32	50	80	155	160	211	175	45	9	42	132	200	157	125	175	140	9	253	307	575	98	44		
32-200/30/C	32	50	80	165	180	228	185	45	10	60	160	250	170	140	200	160	12	284	345	615	98	66		
32-200/40/C	32	50	80	165	180	235	206	45	12	48	160	250	175	140	235	190	12	284	366	660	98	89		
32-250/55/C	32	50	100	192	225	281	260	56	13	48	180	300	222	140	272	216	12	345	440	717	98	135		
32-250/75/C	32	50	100	192	225	281	260	56	13	48	180	300	222	140	272	216	12	345	440	717	98	130		
32-250/110/C	32	50	100	222	225	330	290	64	15	20	180	350	305	210	318	254	14	350	470	905	98	208		
40-125/11/C	40	65	80	155	140	205	165	40	8	32	112	200	130	100	160	125	9	218	277	522	100	42		
40-125/15/C	40	65	80	155	140	211	175	45	9	22	112	200	157	100	175	140	9	218	287	575	100	48		
40-125/22/C	40	65	80	155	140	211	175	45	9	22	112	200	157	125	175	140	9	218	287	575	100	43		
40-160/40Y/C	40	65	80	165	160	235	206	45	12	20	132	250	175	140	235	190	12	253	338	660	100	83		
40-160/55Y/C	40	65	80	192	160	281	260	56	13	28	160	300	222	140	272	216	12	300	392	697	100	116		
40-200/75Y/C	40	65	100	192	180	281	260	56	13	28	160	300	222	140	272	216	12	300	420	717	100	121		
40-200/110Y/C	40	65	100	222	180	330	290	64	15	20	180	350	305	210	318	254	14	350	470	905	100	204		
40-250/110A/C	40	65	100	222	225	330	290	64	15	20	180	350	305	210	318	254	14	350	470	905	107	207		
40-250/150Y/C	40	65	100	222	225	330	290	64	15	20	180	350	305	210	318	254	14	350	470	905	107	207		
40-250/150/C	40	65	100	222	225	330	290	64	15	20	180	350	305	210	318	254	14	350	470	905	107	220		
50-125/22/C	50	65	100	155	160	211	175	45	9	42	132	200	157	125	175	140	9	253	307	595	104	47		
50-125/30/C	50	65	100	165	160	228	185	45	10	32	132	250	170	140	200	160	12	253	317	635	104	59		
50-125/55Y/C	50	65	100	192	160	281	260	56	13	28	160	300	222	140	272	216	12	300	420	717	104	116		
50-160/75Y/C	50	65	100	192	180	281	260	56	13	28	160	300	222	140	272	216	12	300	420	717	104	120		
50-160/75/C	50	65	100	192	180	281	260	56	13	28	160	300	222	140	272	216	12	300	420	717	104	120		
50-200/110A/C	50	65	100	222	200	330	290	64	15	20	180	350	305	210	318	254	14	350	470	905	104	204		
50-200/150Y/C	50	65	100	222	200	330	290	64	15	20	180	350	305	210	318	254	14	350	470	905	104	208		
50-250/150/C	50	65	100	222	225	330	290	64	15	20	180	350	305	210	318	254	14	350	470	905	107	226		
50-250/185/C	50	65	100	222	225	330	290	64	15	20	180	350	305	254	318	254	14	350	470	905	107	238		
50-250/220/C	50	65	100	228	225	361	346	75	18	25	225	400	360	305	393	318	18	400	571	1085	107	325		
65-160/40/C	65	80	100	165	200	235	206	45	12	48	160	250	175	140	235	190	12	310	366	680	130	98		
65-160/55/C	65	80	100	192	200	281	260	56	13	28	160	300	222	140	272	216	12	310	420	717	130	136		
65-160/75/C	65	80	100	192	200	281	260	56	13	28	160	300	222	140	272	216	12	310	420	717	130	132		
65-160/110A/C	65	80	100	222	200	330	290	64	15	20	180	350	305	210	318	254	14	350	470	905	130	194		
65-160/110/C	65	80	100	222	200	330	290	64	15	20	180	350	305	210	318	254	14	350	470	905	130	198		
65-200/150/C	65	80	100	222	225	330	290	64	15	20	180	350	305	210	318	254	14	350	470	905	130	225		
65-200/185/C	65	80	100	222	225	330	290	64	15	20	180	350	305	254	318	254	14	350	470	905	130	235		
65-200/220/C	65	80	100	228	225	361	346	75	18	25	225	400	360	305	393	318	18	400	571	1085	130	330		
80-160/150Y/C	80	100	125	222	225	330	290	64	15	20	180	350	305	210	318	254	14	350	470	930	160	194		
80-160/150/C	80	100	125	222	225	330	290	64	15	20	180	350	305	210	318	254	14	350	470	930	160	230		
80-160/185/C	80	100	125	222	225	330	290	64	15	20	180	350	305	254	318	254	14	350	470	930	160	242		
80-200/300Y/C	80	100	125	228	250	361	346	75	18	25	225	400	360	305	393	318	18	400	571	1110	160	325		

* Minimum motor shims height. Shims supplied as accessories.

ESHS SERIES - ATEX VERSION
DIMENSIONS AND WEIGHTS AT 50 Hz, 4 POLES

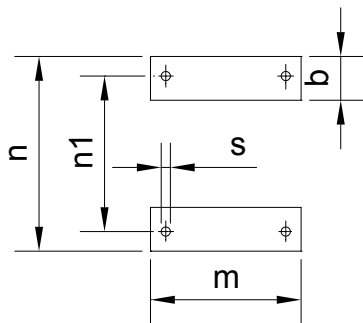
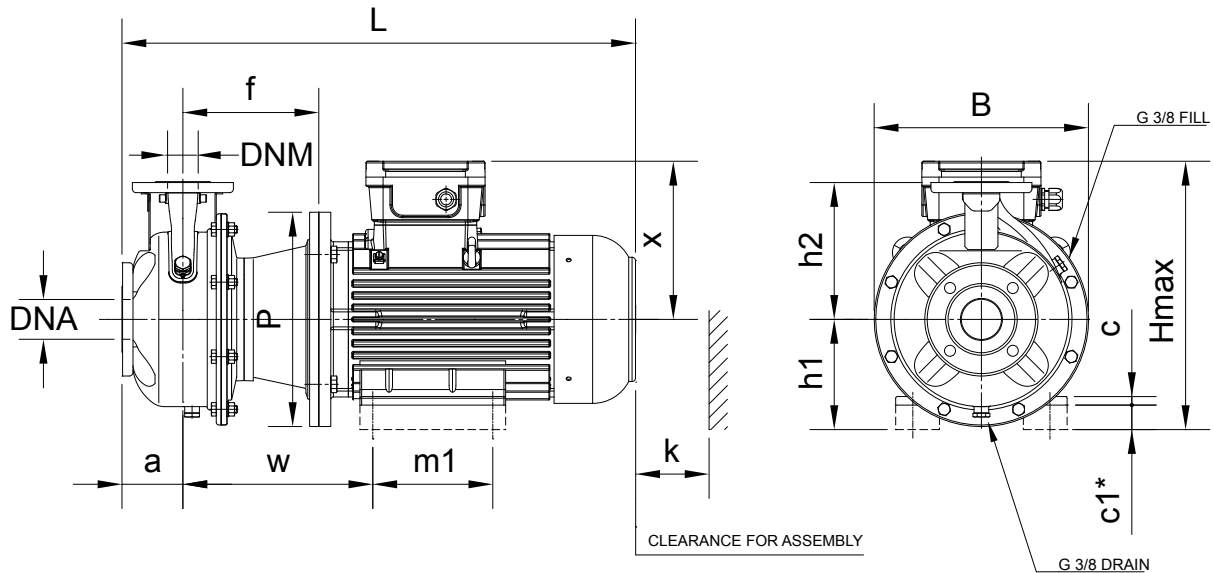

PUMP FLANGES

DN	D	M	G	HOLES		MAX. THICKNESS
				N°	DIA.	
25	115	85	56	4	18	16
32	140	100	64	4	18	16
40	150	110	68	4	18	16
50	165	125	83	4	18	18
65	185	145	104	4	18	18
80	200	160	116	8	18	20
100	225	180	142	8	18	20

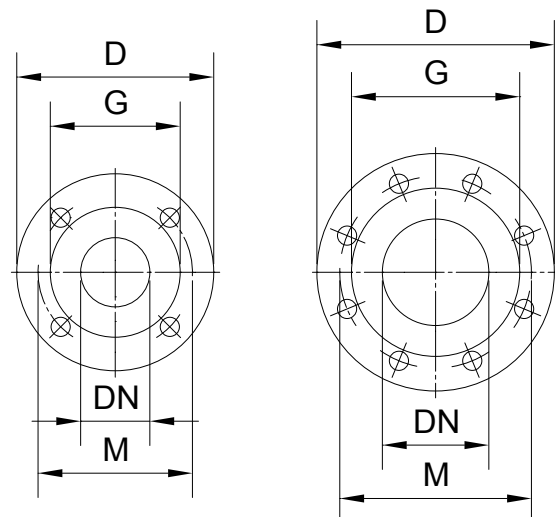

A0054-EN_A_DD

* Minimum motor shims height. Shims supplied as accessories.

ESHS SERIES - ATEX VERSION DIMENSIONS AND WEIGHTS AT 50 Hz, 4 POLES

PUMP TYPE ESHS.4...-EX2	DIMENSIONS (mm)																		B	H	L	k	WEIGHT kg
	PUMP						MOTOR FEET																
	DNM	DNA	a	f	h2	w	x	b	c	c1*	h1	P	m	m1	n	n1	s	max					
25-250/07/C	25	50	100	155	225	205	165	40	8	100	180	200	130	100	160	125	9	345	405	542	98	56	
25-250/11/C	25	50	100	155	225	211	175	45	9	90	180	200	157	100	175	140	9	345	405	595	98	63	
25-250/15/C	25	50	100	155	225	211	175	45	9	90	180	200	157	125	175	140	9	345	405	595	98	61	
32-250/07/C	32	50	100	155	225	205	165	40	8	100	180	200	130	100	160	125	9	345	405	542	98	56	
32-250/11/C	32	50	100	155	225	211	175	45	9	90	180	200	157	100	175	140	9	345	405	595	98	63	
32-250/15/C	32	50	100	155	225	211	175	45	9	90	180	200	157	125	175	140	9	345	405	595	98	61	
40-200/07/C	40	65	100	155	180	205	165	40	8	80	160	200	130	100	160	125	9	284	340	542	100	45	
40-200/11/C	40	65	100	155	180	211	175	45	9	70	160	200	157	100	175	140	9	284	340	595	100	51	
40-250/15Y/C	40	65	100	155	225	211	175	45	9	90	180	200	157	125	175	140	9	345	405	595	107	65	
40-250/15/C	40	65	100	155	225	211	175	45	9	90	180	200	157	125	175	140	9	345	405	595	107	75	
40-250/22/C	40	65	100	165	225	228	185	45	10	80	180	250	170	140	200	160	12	345	405	635	107	75	
50-160/07/C	50	65	100	155	180	205	165	40	8	80	160	200	130	100	160	125	9	253	340	542	104	44	
50-160/11/C	50	65	100	155	180	211	175	45	9	70	160	200	157	100	175	140	9	253	340	595	104	50	
50-200/11/C	50	65	100	155	200	211	175	45	9	70	160	200	157	100	175	140	9	310	360	595	104	63	
50-200/15/C	50	65	100	155	200	211	175	45	9	70	160	200	157	125	175	140	9	310	360	595	104	63	
50-250/22A/C	50	65	100	165	225	228	185	45	10	80	180	250	170	140	200	160	12	345	405	635	107	65	
50-250/22/C	50	65	100	165	225	228	185	45	10	80	180	250	170	140	200	160	12	345	405	635	107	66	
50-250/30/C	50	65	100	165	225	228	185	45	10	80	180	250	170	140	200	160	12	345	405	635	107	72	
65-160/07Y/C	65	80	100	155	200	205	165	40	8	80	160	200	130	100	160	125	9	310	360	542	130	50	
65-160/07/C	65	80	100	155	200	205	165	40	8	80	160	200	130	100	160	125	9	310	360	542	130	52	
65-160/11A/C	65	80	100	155	200	211	175	45	9	70	160	200	157	100	175	140	9	310	360	595	130	60	
65-160/11/C	65	80	100	155	200	211	175	45	9	70	160	200	157	100	175	140	9	310	360	595	130	62	
65-160/15/C	65	80	100	155	200	211	175	45	9	70	160	200	157	125	175	140	9	310	360	595	130	62	
65-200/22Y/C	65	80	100	165	225	228	185	45	10	80	180	250	170	140	200	160	12	310	405	635	130	78	
65-200/22/C	65	80	100	165	225	228	185	45	10	80	180	250	170	140	200	160	12	310	405	635	130	78	
65-200/30/C	65	80	100	165	225	228	185	45	10	80	180	250	170	140	200	160	12	310	405	635	130	79	
65-250/40/C	65	80	100	165	250	235	206	45	12	88	200	250	175	140	235	190	12	345	450	680	140	105	
65-250/55/C	65	80	100	192	250	281	260	56	13	68	200	300	222	140	272	216	12	345	460	717	140	136	
80-160/15/C	80	100	125	155	225	211	175	45	9	90	180	200	157	125	175	140	9	345	405	620	160	70	
80-160/22A/C	80	100	125	165	225	228	185	45	10	80	180	250	170	140	200	160	12	345	405	660	160	74	
80-160/22/C	80	100	125	165	225	228	185	45	10	80	180	250	170	140	200	160	12	345	405	660	160	74	
80-200/30/C	80	100	125	165	250	228	185	45	10	80	180	250	170	140	200	160	12	345	430	660	160	79	
80-200/55Y/C	80	100	125	192	250	281	260	56	13	48	180	300	222	140	272	216	12	345	440	742	160	126	
80-250/55/C	80	100	125	192	280	281	260	56	13	68	200	300	222	140	272	216	12	383	480	742	160	139	
80-250/75/C	80	100	125	192	280	281	260	56	13	68	200	300	222	178	272	216	12	383	480	817	160	145	
80-250/110/C	80	100	125	222	280	330	290	64	15	40	200	350	305	210	318	254	14	383	490	930	160	207	

* Minimum motor shims height. Shims supplied as accessories.

ESHS_4p50_EX2-en_a_td

ESHS SERIES - ATEX VERSION
DIMENSIONS AND WEIGHTS AT 60 Hz, 2 POLES

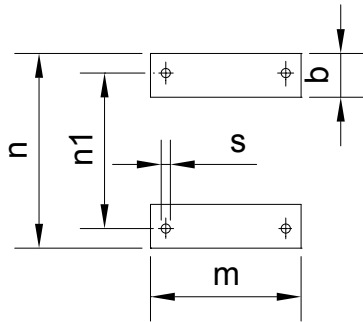
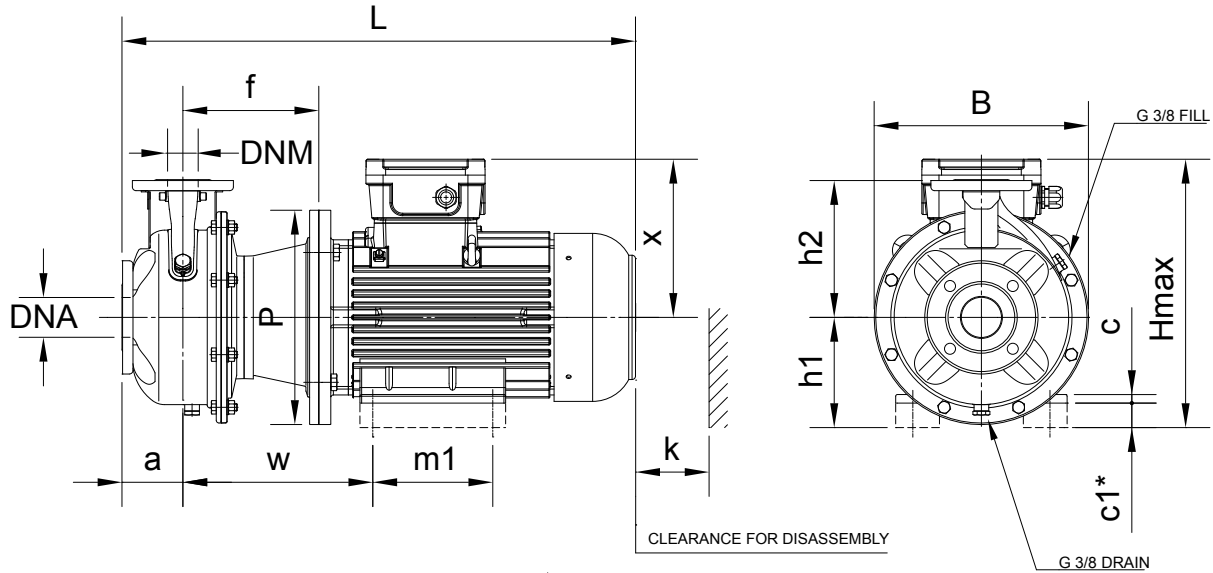

PUMP FLANGES

DN	D	M	G	HOLES		MAX. THICKNESS
				N°	DIA.	
25	115	85	56	4	18	16
32	140	100	64	4	18	16
40	150	110	68	4	18	16
50	165	125	83	4	18	18
65	185	145	104	4	18	18
80	200	160	116	8	18	20
100	225	180	142	8	18	20

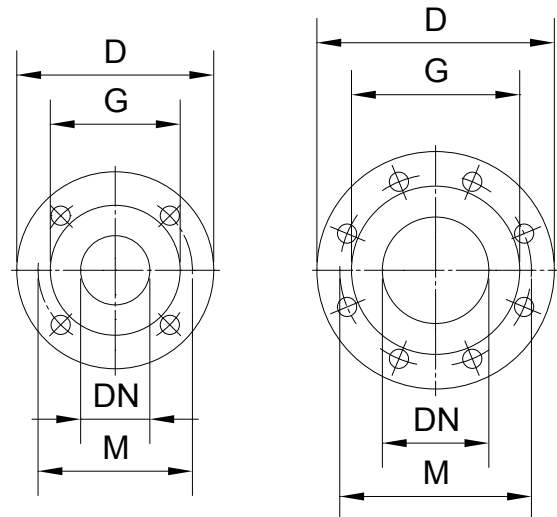

A0055-EN_A_DD

* Minimum motor shims height. Shims supplied as accessories.

ESHS SERIES - ATEX VERSION DIMENSIONS AND WEIGHTS AT 60 Hz, 2 POLES

PUMP TYPE ESHS..2....EX2	DIMENSIONS (mm)																				WEIGHT kg	
	PUMP										MOTOR FEET											
	DNM	DNA	a	f	h2	w	x	b	c	c1*	h1	P	m	m1	n	n1	s	B	H max	L		k
25-125/11/C	25	50	80	155	140	205	165	40	8	80	160	200	130	100	160	125	9	218	325	522	98	41
25-160/22Y/C	25	50	80	155	160	211	175	45	9	70	160	200	157	125	175	140	9	253	335	575	98	49
25-160/22/C	25	50	80	155	160	211	175	45	9	70	160	200	157	125	175	140	9	253	335	575	98	44
25-200/30/C	25	50	80	165	180	228	185	45	10	60	160	250	170	140	200	160	12	284	345	615	98	66
25-200/40/C	25	50	80	165	180	235	206	45	12	48	160	250	175	140	235	190	12	284	366	660	98	89
25-250/55/C	25	50	100	192	225	281	260	56	13	48	180	300	222	140	272	216	12	345	440	717	98	135
25-250/75/C	25	50	100	192	225	281	260	56	13	48	180	300	222	140	272	216	12	345	440	792	98	130
25-250/110A/C	25	50	100	222	225	330	290	64	15	20	180	350	305	210	318	254	14	350	470	905	98	208
25-250/110/C	25	50	100	222	225	330	290	64	15	20	180	350	305	210	318	254	14	350	470	905	98	208
32-125/11/C	32	50	80	155	140	205	165	40	8	32	112	200	130	100	160	125	9	218	277	522	98	41
32-160/22Y/C	32	50	80	155	160	211	175	45	9	42	132	200	157	125	175	140	9	253	307	575	98	49
32-160/22/C	32	50	80	155	160	211	175	45	9	42	132	200	157	125	175	140	9	253	307	575	98	44
32-200/30/C	32	50	80	165	180	228	185	45	10	60	160	250	170	140	200	160	12	284	345	615	98	66
32-200/55Y/C	32	50	80	192	180	281	260	56	13	28	160	300	222	140	272	216	12	300	420	697	98	119
32-250/55/C	32	50	100	192	225	281	260	56	13	48	180	300	222	140	272	216	12	345	440	717	98	135
32-250/75/C	32	50	100	192	225	281	260	56	13	48	180	300	222	140	272	216	12	345	440	792	98	130
32-250/110A/C	32	50	100	222	225	330	290	64	15	20	180	350	305	210	318	254	14	350	470	905	98	208
32-250/110/C	32	50	100	222	225	330	290	64	15	20	180	350	305	210	318	254	14	350	470	905	98	208
40-125/15/C	40	65	80	155	140	211	175	45	9	22	112	200	157	100	175	140	9	218	287	575	100	47
40-125/22/C	40	65	80	155	140	211	175	45	9	22	112	200	157	125	175	140	9	218	287	575	100	43
40-160/40Y/C	40	65	80	165	160	235	206	45	12	20	132	250	175	140	235	190	12	253	338	660	100	83
40-160/40/C	40	65	80	165	160	235	206	45	12	20	132	250	175	140	235	190	12	253	338	660	100	86
40-200/75Y/C	40	65	100	192	180	281	260	56	13	28	160	300	222	140	272	216	12	300	420	792	100	121
40-200/75/C	40	65	100	192	180	281	260	56	13	28	160	300	222	140	272	216	12	300	420	792	100	119
40-250/110A/C	40	65	100	222	225	330	290	64	15	20	180	350	305	210	318	254	14	350	470	905	107	207
40-250/110/C	40	65	100	222	225	330	290	64	15	20	180	350	305	210	318	254	14	350	470	905	107	207
40-250/150/C	40	65	100	222	225	330	290	64	15	20	180	350	305	210	318	254	14	350	470	905	107	220
50-125/30/C	50	65	100	165	160	228	185	45	10	32	132	250	170	140	200	160	12	253	317	635	104	59
50-125/55Y/C	50	65	100	192	160	281	260	56	13	28	160	300	222	140	272	216	12	300	420	717	104	116
50-160/55/C	50	65	100	192	180	281	260	56	13	28	160	300	222	140	272	216	12	300	420	717	104	120
50-160/75/C	50	65	100	192	180	281	260	56	13	28	160	300	222	140	272	216	12	300	420	792	104	120
50-200/110A/C	50	65	100	222	200	330	290	64	15	20	180	350	305	210	318	254	14	350	470	905	104	208
50-200/110/C	50	65	100	222	200	330	290	64	15	20	180	350	305	210	318	254	14	350	470	905	104	208
50-250/150/C	50	65	100	222	225	330	290	64	15	20	180	350	305	210	318	254	14	350	470	905	107	226
50-250/185/C	50	65	100	222	225	330	290	64	15	20	180	350	305	254	318	254	14	350	470	905	107	238
50-250/220/C	50	65	100	228	225	361	346	75	18	25	225	400	360	305	393	318	18	400	571	1085	107	325
65-160/55/C	65	80	100	192	200	281	260	56	13	28	160	300	222	140	272	216	12	310	420	717	130	136
65-160/75/C	65	80	100	192	200	281	260	56	13	28	160	300	222	140	272	216	12	310	420	792	130	132
65-160/110A/C	65	80	100	222	200	330	290	64	15	20	180	350	305	210	318	254	14	350	470	905	130	198
65-160/110/C	65	80	100	222	200	330	290	64	15	20	180	350	305	210	318	254	14	350	470	905	130	198
65-200/150/C	65	80	100	222	225	330	290	64	15	20	180	350	305	210	318	254	14	350	470	905	130	225
65-200/185/C	65	80	100	222	225	330	290	64	15	20	180	350	305	254	318	254	14	350	470	905	130	235
65-200/220/C	65	80	100	228	225	361	346	75	18	25	225	400	360	305	393	318	18	400	571	1085	130	330
65-250/300/C	65	80	100	228	250	361	346	75	18	25	225	400	360	305	393	318	18	400	571	1085	140	370
80-160/150/C	80	100	125	222	225	330	290	64	15	20	180	350	305	210	318	254	14	350	470	930	160	230
80-160/185/C	80	100	125	222	225	330	290	64	15	20	180	350	305	254	318	254	14	350	470	930	160	242
80-200/220/C	80	100	125	228	250	361	346	75	18	25	225	400	360	305	393	318	18	400	571	1110	160	325

* Minimum motor shims height. Shims supplied as accessories.

ESHS_2p60_EX2-en_a_td

ESHS SERIES - ATEX VERSION
DIMENSIONS AND WEIGHTS AT 60 Hz, 4 POLES

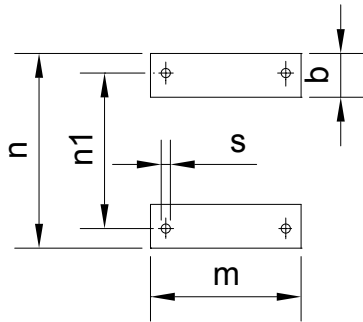
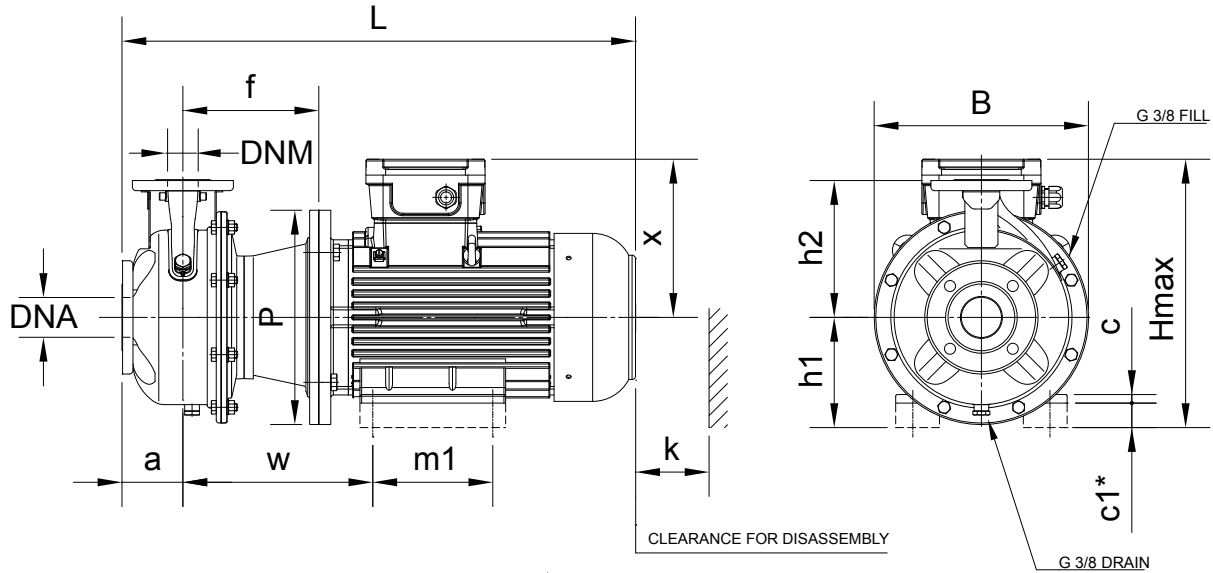

PUMP FLANGES

DN	D	M	G	HOLES		MAX. THICKNESS
				N°	DIA.	
25	115	85	56	4	18	16
32	140	100	64	4	18	16
40	150	110	68	4	18	16
50	165	125	83	4	18	18
65	185	145	104	4	18	18
80	200	160	116	8	18	20
100	225	180	142	8	18	20

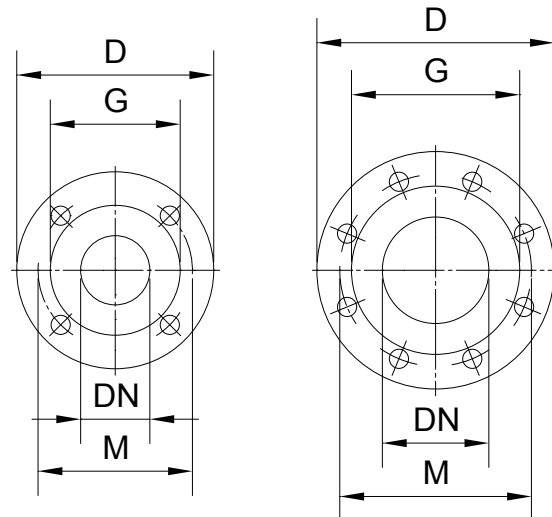

A0055-EN_A_DD

* Minimum motor shims height. Shims supplied as accessories.

ESHS SERIES - ATEX VERSION DIMENSIONS AND WEIGHTS AT 60 Hz, 4 POLES

PUMP TYPE ESHS..4....EX2	DIMENSIONS (mm)																			B	H max	L	k	WEIGHT kg
	PUMP									MOTOR FEET														
	DNM	DNA	a	f	h2	w	x	b	c	c1*	h1	P	m	m1	n	n1	s							
25-250/07/C	25	50	100	155	225	205	165	40	8	100	180	200	130	100	160	125	9	345	405	542	98	56		
25-250/15Y/C	25	50	100	155	225	211	175	45	9	90	180	200	157	125	175	140	9	345	405	595	98	63		
25-250/15/C	25	50	100	155	225	211	175	45	9	90	180	200	157	125	175	140	9	345	405	595	98	61		
32-250/07/C	32	50	100	155	225	205	165	40	8	100	180	200	130	100	160	125	9	345	405	542	98	56		
32-250/11/C	32	50	100	155	225	211	175	45	9	90	180	200	157	100	175	140	9	345	405	595	98	63		
32-250/15/C	32	50	100	155	225	211	175	45	9	90	180	200	157	125	175	140	9	345	405	595	98	61		
40-200/07/C	40	65	100	155	180	205	165	40	8	80	160	200	130	100	160	125	9	284	340	542	100	45		
40-200/11/C	40	65	100	155	180	211	175	45	9	70	160	200	157	100	175	140	9	284	340	595	100	51		
40-250/11/C	40	65	100	155	225	211	175	45	9	90	180	200	157	100	175	140	9	345	405	595	107	65		
40-250/15/C	40	65	100	155	225	211	175	45	9	90	180	200	157	125	175	140	9	345	405	595	107	75		
40-250/22/C	40	65	100	165	225	228	185	45	10	80	180	250	170	140	200	160	12	345	405	635	107	75		
50-160/07/C	50	65	100	155	180	205	165	40	8	80	160	200	130	100	160	125	9	253	340	542	104	44		
50-160/11/C	50	65	100	155	180	211	175	45	9	70	160	200	157	100	175	140	9	253	340	595	104	50		
50-200/15Y/C	50	65	100	155	200	211	175	45	9	70	160	200	157	125	175	140	9	310	360	595	104	63		
50-200/15/C	50	65	100	155	200	211	175	45	9	70	160	200	157	125	175	140	9	310	360	595	104	63		
50-250/22A/C	50	65	100	165	225	228	185	45	10	80	180	250	170	140	200	160	12	345	405	635	107	65		
50-250/30Y/C	50	65	100	165	225	228	185	45	10	80	180	250	170	140	200	160	12	345	405	635	107	66		
50-250/40Y/C	50	65	100	165	225	235	206	45	12	68	180	250	175	140	235	190	12	345	405	680	107	91		
65-160/07/C	65	80	100	155	200	205	165	40	8	80	160	200	130	100	160	125	9	310	360	542	130	52		
65-160/11A/C	65	80	100	155	200	211	175	45	9	70	160	200	157	100	175	140	9	310	360	595	130	60		
65-160/15Y/C	65	80	100	155	200	211	175	45	9	70	160	200	157	125	175	140	9	310	360	595	130	62		
65-160/15/C	65	80	100	155	200	211	175	45	9	70	160	200	157	125	175	140	9	310	360	595	130	62		
65-200/22Y/C	65	80	100	165	225	228	185	45	10	80	180	250	170	140	200	160	12	310	405	635	130	78		
65-200/22/C	65	80	100	165	225	228	185	45	10	80	180	250	170	140	200	160	12	310	405	635	130	78		
65-200/30/C	65	80	100	165	225	228	185	45	10	80	180	250	170	140	200	160	12	310	405	635	130	79		
65-250/40/C	65	80	100	165	250	235	206	45	12	88	200	250	175	140	235	190	12	345	450	680	140	105		
65-250/55/C	65	80	100	192	250	281	260	56	13	68	200	300	222	140	272	216	12	345	460	792	140	136		
80-160/22A/C	80	100	125	165	225	228	185	45	10	80	180	250	170	140	200	160	12	345	405	660	160	74		
80-160/22/C	80	100	125	165	225	228	185	45	10	80	180	250	170	140	200	160	12	345	405	660	160	74		
80-200/30/C	80	100	125	165	250	228	185	45	10	80	180	250	170	140	200	160	12	345	430	660	160	79		
80-200/40/C	80	100	125	165	250	235	206	45	12	68	180	250	175	140	235	190	12	345	430	705	160	96		
80-250/55/C	80	100	125	192	280	281	260	56	13	68	200	300	222	140	272	216	12	383	480	817	160	139		
80-250/75/C	80	100	125	192	280	281	260	56	13	68	200	300	222	178	272	216	12	383	480	817	160	145		
80-250/110/C	80	100	125	222	280	330	290	64	15	40	200	350	305	210	318	254	14	383	490	930	160	207		

* Minimum motor shims height. Shims supplied as accessories.

ESHS_4p60_EX2-en_a_td

ESHF SERIES - ATEX VERSION
DIMENSIONS AND WEIGHTS AT 50 Hz, 2 POLES

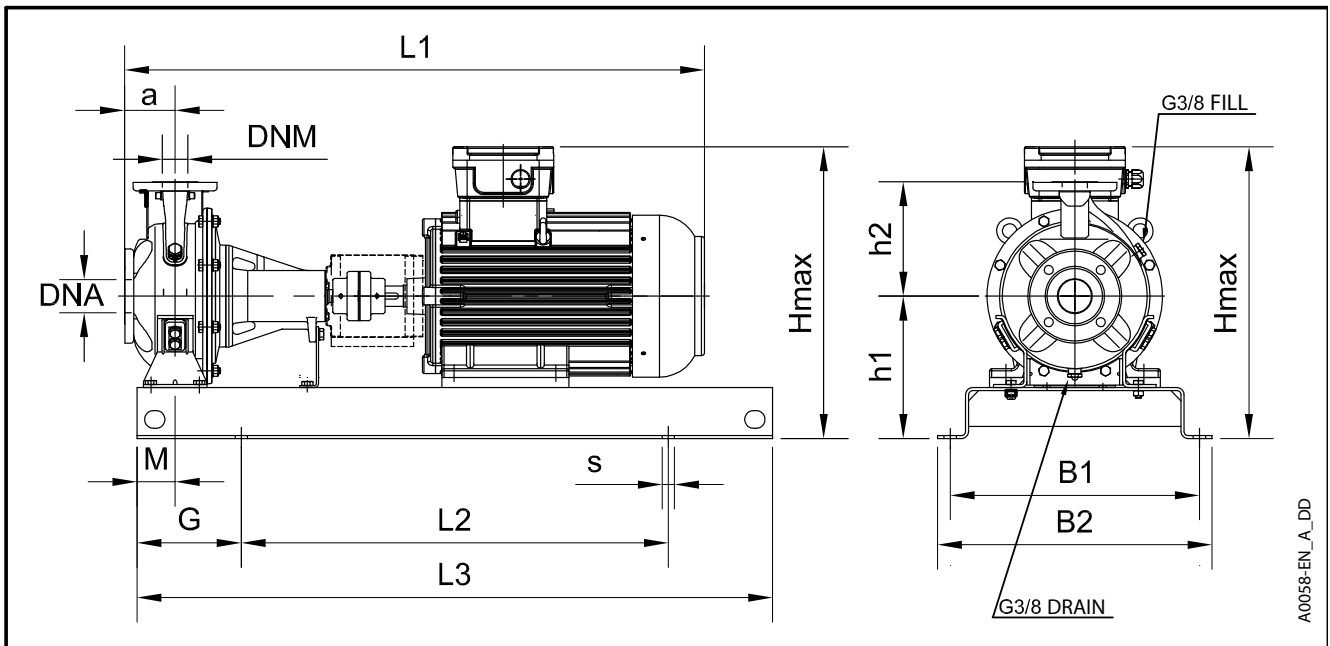

A0058-EN_A_DD

ESHF SERIES - ATEX VERSION

DIMENSIONS AND WEIGHTS AT 50 Hz, 2 POLES

PUMP TYPE ESHF..2...EX2	DIMENSIONS (mm)													s for SCREWS	WEIGHT kg	COUPLING TYPE*
	DNM	DNA	a	B1	B2	L1	L2	L3	G	M	h1	h2	Hmax			
25-125/11Y/C	25	50	80	320	360	770	540	800	130	60	212	140	377	M16	83	A2
25-125/11/C	25	50	80	320	360	770	540	800	130	60	212	140	377	M16	85	A2
25-160/22Y/C	25	50	80	350	390	833	600	900	150	60	232	160	407	M16	89	A3
25-160/22/C	25	50	80	350	390	833	600	900	150	60	232	160	407	M16	90	A3
25-200/30/C	25	50	80	350	390	873	600	900	150	60	260	180	445	M16	117	B1
25-200/40/C	25	50	80	350	390	918	600	900	150	60	260	180	466	M16	133	B1
25-250/55/C	25	50	100	440	490	968	740	1120	190	75	280	225	540	M20	168	C1
25-250/75/C	25	50	100	440	490	968	740	1120	190	75	280	225	540	M20	177	C1
25-250/110/C	25	50	100	490	540	1156	840	1250	205	75	280	225	570	M20	281	C2
32-125/11Y/C	32	50	80	320	360	770	540	800	130	60	212	140	377	M16	83	A2
32-125/11/C	32	50	80	320	360	770	540	800	130	60	212	140	377	M16	85	A2
32-160/22Y/C	32	50	80	350	390	833	600	900	150	60	232	160	407	M16	89	A3
32-160/22/C	32	50	80	350	390	833	600	900	150	60	232	160	407	M16	90	A3
32-200/30/C	32	50	80	350	390	873	600	900	150	60	260	180	445	M16	117	B1
32-200/40/C	32	50	80	350	390	918	600	900	150	60	260	180	466	M16	133	B1
32-250/55/C	32	50	100	440	490	968	740	1120	190	75	280	225	540	M20	168	C1
32-250/75/C	32	50	100	440	490	968	740	1120	190	75	280	225	540	M20	177	C1
32-250/110/C	32	50	100	490	540	1156	840	1250	205	75	280	225	570	M20	281	C2
40-125/11/C	40	65	80	350	390	770	600	900	150	60	212	140	377	M16	86	A2
40-125/15/C	40	65	80	350	390	833	600	900	150	60	212	140	387	M16	90	A3
40-125/22/C	40	65	80	350	390	833	600	900	150	60	212	140	387	M16	92	A3
40-160/40Y/C	40	65	80	350	390	918	600	900	150	60	232	160	438	M16	133	B1
40-160/55Y/C	40	65	80	400	450	948	660	1000	170	60	232	160	492	M20	168	C1
40-200/75Y/C	40	65	100	400	450	968	660	1000	170	60	260	180	520	M20	161	C1
40-200/110Y/C	40	65	100	440	490	1156	740	1120	190	60	260	180	550	M20	262	C2
40-250/110A/C	40	65	100	490	540	1156	840	1250	205	75	280	225	570	M20	267	C2
40-250/150Y/C	40	65	100	490	540	1156	840	1250	205	75	280	225	570	M20	270	C2
40-250/150/C	40	65	100	490	540	1156	840	1250	205	75	280	225	570	M20	258	C2
50-125/22/C	50	65	100	350	390	853	600	900	150	60	232	160	407	M16	99	A3
50-125/30/C	50	65	100	350	390	893	600	900	150	60	232	160	417	M16	114	B1
50-125/55Y/C	50	65	100	400	450	968	660	1000	170	60	232	160	492	M20	167	C1
50-160/75Y/C	50	65	100	400	450	968	660	1000	170	60	260	180	520	M20	158	C1
50-160/75/C	50	65	100	400	450	968	660	1000	170	60	260	180	520	M20	165	C1
50-200/110A/C	50	65	100	440	490	1156	740	1120	190	60	260	200	550	M20	245	C2
50-200/150Y/C	50	65	100	440	490	1156	740	1120	190	60	260	200	550	M20	250	C2
50-250/150/C	50	65	100	490	540	1156	840	1250	205	75	280	225	570	M20	248	C2
50-250/185/C	50	65	100	490	540	1156	840	1250	205	75	280	225	570	M20	255	C2
50-250/220/C	50	65	100	550	610	1330	940	1400	230	75	310	225	656	M24	404	E2
65-160/40/C	65	80	100	400	450	938	660	1000	170	75	260	200	466	M20	169	B1
65-160/55/C	65	80	100	440	490	968	740	1120	190	75	260	200	520	M20	193	C1
65-160/75/C	65	80	100	440	490	968	740	1120	190	75	260	200	520	M20	202	C1
65-160/110A/C	65	80	100	490	540	1156	840	1250	205	75	260	200	550	M20	262	C2
65-160/110/C	65	80	100	490	540	1156	840	1250	205	75	260	200	550	M20	262	C2
65-200/150/C	65	80	100	490	540	1156	840	1250	205	75	280	225	570	M20	268	C2
65-200/185/C	65	80	100	490	540	1156	840	1250	205	75	280	225	570	M20	275	C2
65-200/220/C	65	80	100	550	610	1330	940	1400	230	75	310	225	656	M24	397	E2
65-250/370Y/C	65	80	100	550	610	1488	940	1400	230	90	365	250	736	M24	439	E1
65-250/450Y/C	65	80	100	600	660	1536	1060	1600	270	90	390	250	786	M24	562	F1
80-160/150Y/C	80	100	125	490	540	1181	840	1250	205	75	280	225	570	M20	298	C2
80-160/150/C	80	100	125	490	540	1181	840	1250	205	75	280	225	570	M20	292	C2
80-160/185/C	80	100	125	490	540	1181	840	1250	205	75	280	225	570	M20	305	C2
80-200/300Y/C	80	100	125	550	610	1465	940	1400	230	75	310	250	656	M24	410	E1
80-200/370Y/C	80	100	125	550	610	1513	940	1400	230	75	365	250	736	M24	440	E1
80-200/450Y/C	80	100	125	600	660	1561	1060	1600	270	75	390	250	786	M24	562	F1
80-250/450/C	80	100	125	600	660	1561	1060	1600	270	90	390	280	786	M24	726	F1
80-250/550/C	80	100	125	670	730	1718	1200	1800	300	90	420	280	968	M24	1145	G1
80-250/750/C	80	100	125	670	730	1718	1200	1800	300	90	420	280	968	M24	1230	G1

* For coupling dimensions please refers to the table "Flexible Coupling Dimensions" at page 48.

ESHF_2p50_EX2-en_a_td

**ESHF SERIES - ATEX VERSION
DIMENSIONS AND WEIGHTS AT 50 Hz, 4 POLES**

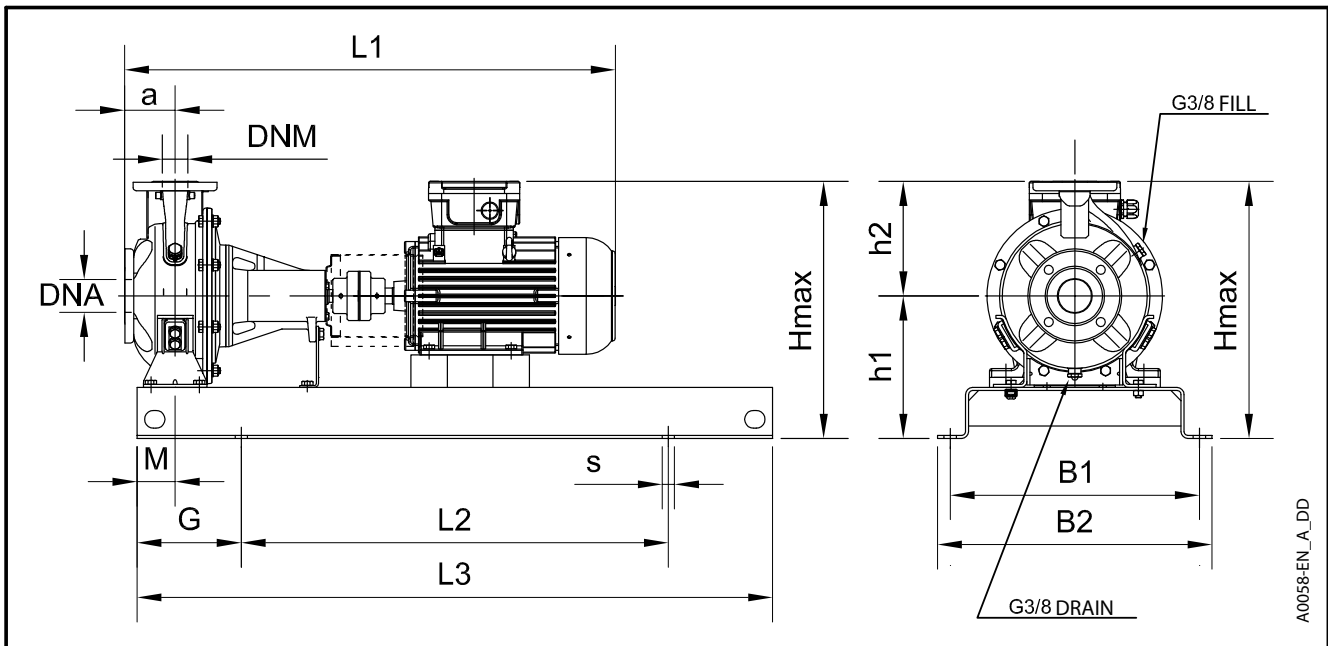

ESHF SERIES - ATEX VERSION DIMENSIONS AND WEIGHTS AT 50 Hz, 4 POLES

PUMP TYPE ESHF..2...EX2	DIMENSIONS (mm)													s for SCREWS	WEIGHT kg	COUPLING TYPE*
	DNM	DNA	a	B1	B2	L1	L2	L3	G	M	h1	h2	Hmax			
25-125/02A/C	25	50	80	320	360	719	540	800	130	60	212	140	367	M16	84	A1
25-125/02/C	25	50	80	320	360	719	540	800	130	60	212	140	367	M16	84	A1
25-160/02A/C	25	50	80	320	360	719	540	800	130	60	232	160	392	M16	86	A1
25-160/03Y/C	25	50	80	320	360	719	540	800	130	60	232	160	392	M16	86	A1
25-200/03/C	25	50	80	320	360	719	540	800	130	60	260	180	440	M16	90	A1
25-200/05/C	25	50	80	320	360	770	540	800	130	60	260	180	440	M16	96	A2
25-250/07/C	25	50	100	400	450	790	660	1000	170	75	280	225	505	M20	112	A2
25-250/11/C	25	50	100	400	450	853	660	1000	170	75	280	225	505	M20	122	A3
25-250/15/C	25	50	100	400	450	853	660	1000	170	75	280	225	505	M20	118	A3
32-125/02A/C	32	50	80	320	360	719	540	800	130	60	212	140	367	M16	84	A1
32-125/02/C	32	50	80	320	360	719	540	800	130	60	212	140	367	M16	84	A1
32-160/02A/C	32	50	80	320	360	719	540	800	130	60	232	160	392	M16	86	A1
32-160/03Y/C	32	50	80	320	360	719	540	800	130	60	232	160	392	M16	86	A1
32-200/03/C	32	50	80	320	360	719	540	800	130	60	260	180	440	M16	90	A1
32-200/05/C	32	50	80	320	360	770	540	800	130	60	260	180	440	M16	96	A2
32-250/07/C	32	50	100	400	450	790	660	1000	170	75	280	225	505	M20	112	A2
32-250/11/C	32	50	100	400	450	853	660	1000	170	75	280	225	505	M20	122	A3
32-250/15/C	32	50	100	400	450	853	660	1000	170	75	280	225	505	M20	118	A3
40-125/02A/C	40	65	80	320	360	719	540	800	130	60	212	140	367	M16	69	A1
40-125/02/C	40	65	80	320	360	719	540	800	130	60	212	140	367	M16	69	A1
40-160/03/C	40	65	80	320	360	719	540	800	130	60	232	160	392	M16	72	A1
40-160/05/C	40	65	80	320	360	770	540	800	130	60	232	160	397	M16	78	A2
40-200/07/C	40	65	100	350	390	790	600	900	150	60	260	180	440	M16	84	A2
40-200/11/C	40	65	100	350	390	853	600	900	150	60	260	180	440	M16	94	A3
40-250/15Y/C	40	65	100	400	450	853	660	1000	170	75	280	225	505	M20	121	A3
40-250/15/C	40	65	100	400	450	853	660	1000	170	75	280	225	505	M20	118	A3
40-250/22/C	40	65	100	400	450	893	660	1000	170	75	280	225	505	M20	137	B1
50-125/02/C	50	65	100	320	360	739	540	800	130	60	232	160	392	M16	71	A1
50-125/03/C	50	65	100	320	360	739	540	800	130	60	232	160	392	M16	71	A1
50-125/05/C	50	65	100	320	360	790	540	800	130	60	232	160	397	M16	77	A2
50-160/07/C	50	65	100	350	390	790	600	900	150	60	260	180	440	M16	83	A2
50-160/11/C	50	65	100	350	390	853	600	900	150	60	260	180	440	M16	93	A3
50-200/11/C	50	65	100	350	390	853	600	900	150	60	260	200	460	M16	104	A3
50-200/15/C	50	65	100	350	390	853	600	900	150	60	260	200	460	M16	101	A3
50-250/22A/C	50	65	100	400	450	893	660	1000	170	75	280	225	505	M20	138	B1
50-250/22/C	50	65	100	400	450	893	660	1000	170	75	280	225	505	M20	138	B1
50-250/30/C	50	65	100	400	450	893	660	1000	170	75	280	225	505	M20	143	B1
65-160/07Y/C	65	80	100	350	390	790	600	900	150	75	260	200	460	M16	100	A2
65-160/07/C	65	80	100	350	390	790	600	900	150	75	260	200	460	M16	100	A2
65-160/11A/C	65	80	100	400	450	853	600	1000	170	75	260	200	460	M20	110	A3
65-160/11/C	65	80	100	400	450	853	660	1000	170	75	260	200	460	M20	110	A3
65-160/15/C	65	80	100	400	450	853	660	1000	170	75	260	200	460	M20	107	A3
65-200/22Y/C	65	80	100	440	490	893	740	1120	190	75	280	225	505	M20	138	B1
65-200/22/C	65	80	100	440	490	893	740	1120	190	75	280	225	505	M20	139	B1
65-200/30/C	65	80	100	440	490	893	740	1120	190	75	280	225	505	M20	144	B1
65-250/40/C	65	80	100	440	490	1048	740	1120	190	90	310	250	560	M20	186	C3
65-250/55/C	65	80	100	440	490	1078	740	1120	190	90	310	250	570	M20	225	C4
80-160/15/C	80	100	125	400	450	878	660	1000	170	75	280	225	505	M20	137	A3
80-160/22A/C	80	100	125	440	490	918	740	1120	190	75	280	225	505	M20	149	B1
80-160/22/C	80	100	125	440	490	918	740	1120	190	75	280	225	505	M20	149	B1
80-200/30/C	80	100	125	440	490	1028	740	1120	190	75	280	250	530	M20	169	C3
80-200/55Y/C	80	100	125	440	490	1103	740	1120	190	75	280	250	540	M20	209	C3
80-250/55/C	80	100	125	490	540	1103	840	1250	205	90	310	280	590	M20	226	C4
80-250/75/C	80	100	125	490	540	1178	840	1250	205	90	310	280	590	M20	228	C4
80-250/110/C	80	100	125	490	540	1291	840	1250	205	90	310	280	600	M20	313	C5

* For coupling dimensions please refer to the table "Flexible Coupling Dimensions" at page 48.

**ESHF SERIES - ATEX VERSION
DIMENSIONS AND WEIGHTS AT 60 Hz, 2 POLES**

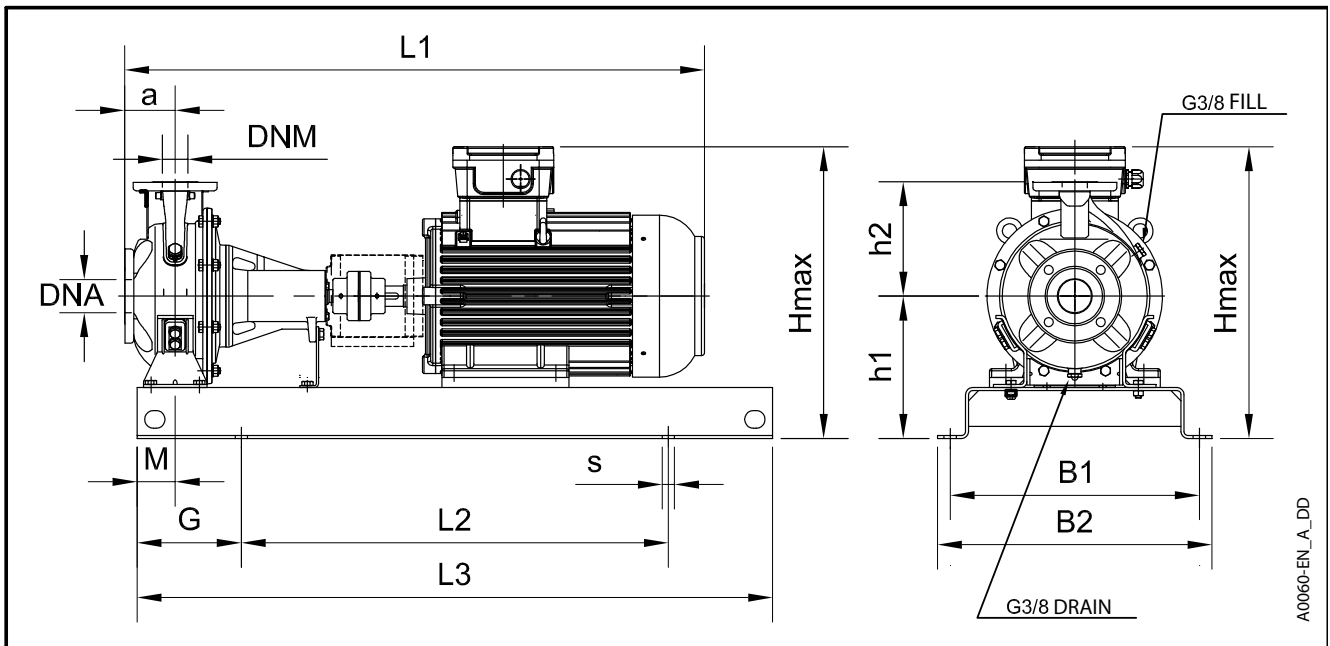

ESHF SERIES - ATEX VERSION DIMENSIONS AND WEIGHTS AT 60 Hz, 2 POLES

PUMP TYPE ESHF...2...EX2	DIMENSIONS (mm)														s for SCREWS	WEIGHT kg	COUPLING TYPE*
	DNM	DNA	a	B1	B2	L1	L2	L3	G	M	h1	h2	Hmax				
25-125/11/C	25	50	80	320	360	770	540	800	130	60	212	140	377	M16	85	A2	
25-160/22Y/C	25	50	80	350	390	833	600	900	150	60	232	160	407	M16	89	A3	
25-160/22/C	25	50	80	350	390	833	600	900	150	60	232	160	407	M16	90	A3	
25-200/30/C	25	50	80	350	390	873	600	900	150	60	260	180	445	M16	117	B1	
25-200/40/C	25	50	80	350	390	918	600	900	150	60	260	180	466	M16	133	B1	
25-250/55/C	25	50	100	440	490	968	740	1120	190	75	280	225	540	M20	168	C1	
25-250/75/C	25	50	100	440	490	1043	740	1120	190	75	280	225	540	M20	177	C1	
25-250/110A/C	25	50	100	490	540	1156	840	1250	205	75	280	225	570	M20	281	C2	
25-250/110/C	25	50	100	490	540	1156	840	1250	205	75	280	225	570	M20	281	C2	
32-125/11/C	32	50	80	320	360	770	540	800	130	60	212	140	377	M16	85	A2	
32-160/22Y/C	32	50	80	350	390	833	600	900	150	60	232	160	407	M16	89	A3	
32-160/22/C	32	50	80	350	390	833	600	900	150	60	232	160	407	M16	90	A3	
32-200/30/C	32	50	80	350	390	873	600	900	150	60	260	180	445	M16	117	B1	
32-200/55Y/C	32	50	80	400	450	948	660	1000	170	60	260	180	520	M20	168	C1	
32-250/55/C	32	50	100	440	490	968	740	1120	190	75	280	225	540	M20	168	C1	
32-250/75/C	32	50	100	440	490	1043	740	1120	190	75	280	225	540	M20	177	C1	
32-250/110A/C	32	50	100	490	540	1156	840	1250	205	75	280	225	570	M20	281	C2	
32-250/110/C	32	50	100	490	540	1156	840	1250	205	75	280	225	570	M20	281	C2	
40-125/15/C	40	65	80	350	390	833	600	900	150	60	212	140	387	M16	90	A3	
40-125/22/C	40	65	80	350	390	833	600	900	150	60	212	140	387	M16	92	A3	
40-160/40Y/C	40	65	80	350	390	918	600	900	150	60	232	160	438	M16	133	B1	
40-160/40/C	40	65	80	350	390	918	600	900	150	60	232	160	438	M16	132	B1	
40-200/75Y/C	40	65	100	400	450	1043	660	1000	170	60	260	180	520	M20	161	C1	
40-200/75/C	40	65	100	400	450	1043	660	1000	170	60	260	180	520	M20	171	C1	
40-250/110A/C	40	65	100	490	540	1156	840	1250	205	75	280	225	570	M20	270	C2	
40-250/110/C	40	65	100	490	540	1156	840	1250	205	75	280	225	570	M20	270	C2	
40-250/150/C	40	65	100	490	540	1156	840	1250	205	75	280	225	570	M20	258	C2	
50-125/30/C	50	65	100	350	390	893	600	900	150	60	232	160	417	M16	114	B1	
50-125/55Y/C	50	65	100	400	450	968	660	1000	170	60	232	160	492	M20	166	C1	
50-160/55/C	50	65	100	400	450	968	660	1000	170	60	260	180	520	M20	158	C1	
50-160/75/C	50	65	100	400	450	1043	660	1000	170	60	260	180	520	M20	165	C1	
50-200/110A/C	50	65	100	440	490	1156	740	1120	190	60	260	200	550	M20	250	C2	
50-200/110/C	50	65	100	440	490	1156	740	1120	190	60	260	200	550	M20	250	C2	
50-250/150/C	50	65	100	490	540	1156	840	1250	205	75	280	225	570	M20	248	C2	
50-250/185/C	50	65	100	490	540	1156	840	1250	205	75	280	225	570	M20	255	C2	
50-250/220/C	50	65	100	550	610	1330	940	1400	230	75	310	225	656	M24	378	E2	
65-160/55/C	65	80	100	400	450	968	660	1000	170	75	260	200	520	M20	188	C1	
65-160/75/C	65	80	100	400	450	1043	660	1000	170	75	260	200	520	M20	197	C1	
65-160/110A/C	65	80	100	490	540	1156	840	1250	205	75	260	200	550	M20	262	C2	
65-160/110/C	65	80	100	490	540	1156	840	1250	205	75	260	200	550	M20	262	C2	
65-200/150/C	65	80	100	490	540	1156	840	1250	205	75	280	225	570	M20	268	C2	
65-200/185/C	65	80	100	490	540	1156	840	1250	205	75	280	225	570	M20	275	C2	
65-200/220/C	65	80	100	550	610	1330	940	1400	230	75	310	225	656	M24	406	E2	
65-250/300/C	65	80	100	550	610	1440	940	1400	230	90	310	250	656	M24	447	E1	
65-250/370/C	65	80	100	550	610	1488	940	1400	230	90	365	250	736	M24	538	E1	
80-160/150/C	80	100	125	490	540	1181	840	1250	205	75	280	225	570	M20	292	C2	
80-160/185/C	80	100	125	490	540	1181	840	1250	205	75	280	225	570	M20	305	C2	
80-200/220/C	80	100	125	550	610	1465	940	1400	230	75	310	250	656	M24	434	E1	
80-200/370Y/C	80	100	125	550	610	1513	940	1400	230	90	365	250	736	M24	453	E1	
80-200/370/C	80	100	125	550	610	1513	940	1400	230	90	365	250	736	M24	537	E1	
80-250/450/C	80	100	125	600	660	1561	1060	1600	270	90	390	280	786	M24	678	F1	
80-250/550/C	80	100	125	670	730	1718	1200	1800	300	90	420	280	968	M24	1025	G1	
80-250/750/C	80	100	125	670	730	1718	1200	1800	300	90	420	280	968	M24	951	G1	

* For coupling dimensions please refers to the table "Flexible Coupling Dimensions" at page 48.

**ESHF SERIES - ATEX VERSION
DIMENSIONS AND WEIGHTS AT 60 Hz, 4 POLES**

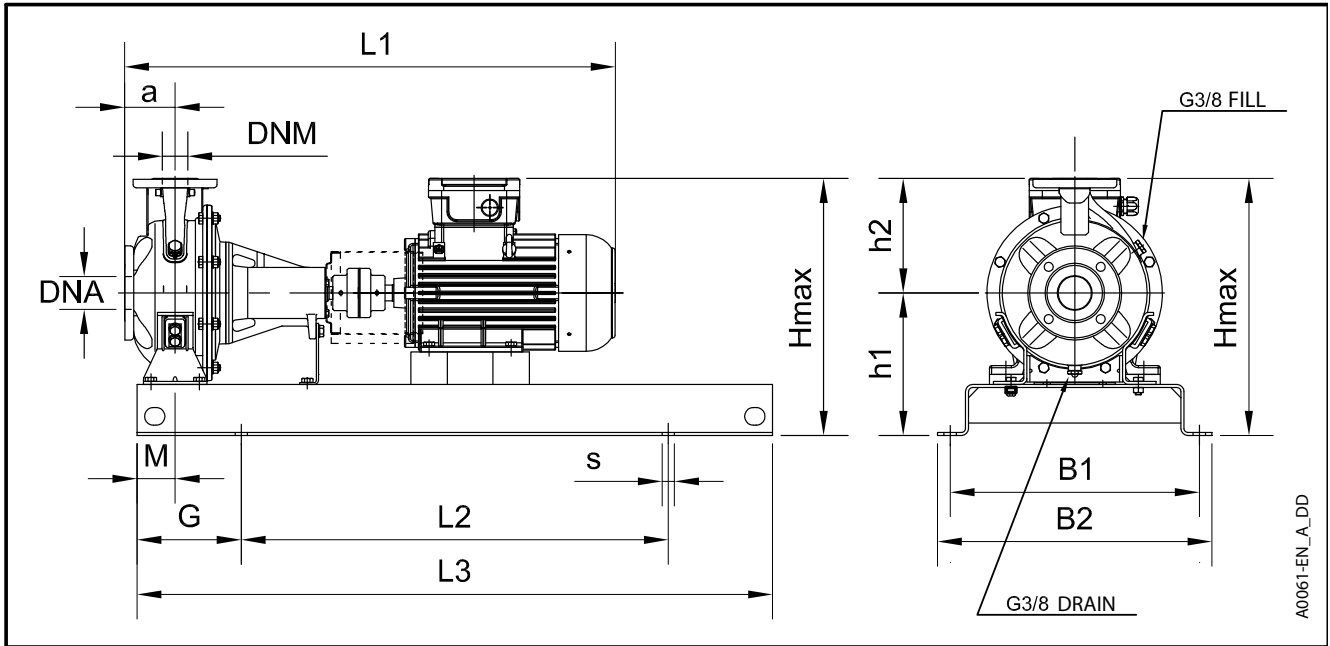

ESHF SERIES - ATEX VERSION

DIMENSIONS AND WEIGHTS AT 60 Hz, 4 POLES

PUMP TYPE ESHF..4...EX2	DIMENSIONS (mm)														s for SCREWS	WEIGHT kg	COUPLING TYPE*
	DNM	DNA	a	B1	B2	L1	L2	L3	G	M	h1	h2	Hmax				
25-125/02/S	25	50	80	320	360	719	540	800	130	60	212	140	367	M16	84	A1	
25-160/02/S	25	50	80	320	360	719	540	800	130	60	232	160	392	M16	86	A1	
25-160/03/S	25	50	80	320	360	719	540	800	130	60	232	160	392	M16	86	A1	
25-200/03/S	25	50	80	320	360	719	540	800	130	60	260	180	440	M16	90	A1	
25-200/07Y/S	25	50	80	320	360	770	540	800	130	60	260	180	440	M16	96	A2	
25-250/07/X	25	50	100	400	450	790	660	1000	170	75	280	225	505	M20	112	A2	
25-250/15Y/P	25	50	100	400	450	853	660	1000	170	75	280	225	505	M20	122	A3	
25-250/15/P	25	50	100	400	450	853	660	1000	170	75	280	225	505	M20	118	A3	
32-125/02/S	32	50	80	320	360	719	540	800	130	60	212	140	367	M16	84	A1	
32-160/02/S	32	50	80	320	360	719	540	800	130	60	232	160	392	M16	86	A1	
32-160/03/S	32	50	80	320	360	719	540	800	130	60	232	160	392	M16	86	A1	
32-200/03/S	32	50	80	320	360	719	540	800	130	60	260	180	440	M16	90	A1	
32-200/07Y/S	32	50	80	320	360	770	540	800	130	60	260	180	440	M16	96	A2	
32-250/07/X	32	50	100	400	450	790	660	1000	170	75	280	225	505	M20	112	A2	
32-250/11/P	32	50	100	400	450	853	660	1000	170	75	280	225	505	M20	122	A3	
32-250/15/P	32	50	100	400	450	853	660	1000	170	75	280	225	505	M20	118	A3	
40-125/02/S	40	65	80	320	360	719	540	800	130	60	212	140	367	M16	69	A1	
40-125/03/S	40	65	80	320	360	719	540	800	130	60	212	140	367	M16	70	A1	
40-160/03/S	40	65	80	320	360	719	540	800	130	60	232	160	392	M16	72	A1	
40-160/05/S	40	65	80	320	360	770	540	800	130	60	232	160	397	M16	78	A2	
40-200/07/X	40	65	100	350	390	790	600	900	150	60	260	180	440	M16	84	A2	
40-200/11/P	40	65	100	350	390	853	600	900	150	60	260	180	440	M16	94	A3	
40-250/11/P	40	65	100	400	450	853	660	1000	170	75	280	225	505	M20	121	A3	
40-250/15/P	40	65	100	400	450	853	660	1000	170	75	280	225	505	M20	118	A3	
40-250/22/P	40	65	100	400	450	893	660	1000	170	75	280	225	505	M20	137	B1	
50-125/03/S	50	65	100	320	360	739	540	800	130	60	232	160	392	M16	71	A1	
50-125/05/S	50	65	100	320	360	790	540	800	130	60	232	160	397	M16	77	A2	
50-160/07/X	50	65	100	350	390	790	600	900	150	60	260	180	440	M16	83	A2	
50-160/11/P	50	65	100	350	390	853	600	900	150	60	260	180	440	M16	93	A3	
50-200/15Y/P	50	65	100	350	390	853	600	900	150	60	260	200	460	M16	104	A3	
50-200/15/P	50	65	100	350	390	853	600	900	150	60	260	200	460	M16	101	A3	
50-250/22A/P	50	65	100	400	450	893	660	1000	170	75	280	225	505	M20	138	B1	
50-250/30Y/P	50	65	100	400	450	893	660	1000	170	75	280	225	505	M20	138	B1	
50-250/40Y/P	50	65	100	400	450	938	660	1000	170	75	280	225	505	M20	162	B1	
65-160/07/X	65	80	100	350	390	790	600	900	150	75	260	200	460	M16	100	A2	
65-160/11A/P	65	80	100	400	450	853	600	1000	170	75	260	200	460	M20	110	A3	
65-160/15Y/P	65	80	100	400	450	853	660	1000	170	75	260	200	460	M20	110	A3	
65-160/15/P	65	80	100	400	450	853	660	1000	170	75	260	200	460	M20	107	A3	
65-200/22Y/P	65	80	100	440	490	893	740	1120	190	75	280	225	505	M20	138	B1	
65-200/22/P	65	80	100	440	490	893	740	1120	190	75	280	225	505	M20	139	B1	
65-200/30/P	65	80	100	440	490	893	740	1120	190	75	280	225	505	M20	144	B1	
65-250/40/P	65	80	100	440	490	1048	740	1120	190	90	310	250	560	M20	186	C3	
65-250/55/P	65	80	100	440	490	1153	740	1120	190	90	310	250	570	M20	225	C4	
80-160/22A/P	80	100	125	440	490	918	740	1120	190	75	280	225	505	M20	149	B1	
80-160/22/P	80	100	125	440	490	918	740	1120	190	75	280	225	505	M20	149	B1	
80-200/30/P	80	100	125	440	490	1028	740	1120	190	75	280	250	530	M20	169	C3	
80-200/40/P	80	100	125	440	490	1073	740	1120	190	75	280	250	530	M20	179	C3	
80-250/55/P	80	100	125	490	540	1178	840	1250	205	90	310	280	590	M20	226	C4	
80-250/75/P	80	100	125	490	540	1178	840	1250	205	90	310	280	590	M20	228	C4	
80-250/110/P	80	100	125	490	540	1291	840	1250	205	90	310	280	600	M20	313	C5	

* For coupling dimensions please refers to the table "Flexible Coupling Dimensions" at page 48.

ESHF_4p60-en_EX2_a_td

ESH SERIES - ATEX VERSION DIMENSIONS AND WEIGHTS (BARE SHAFT)

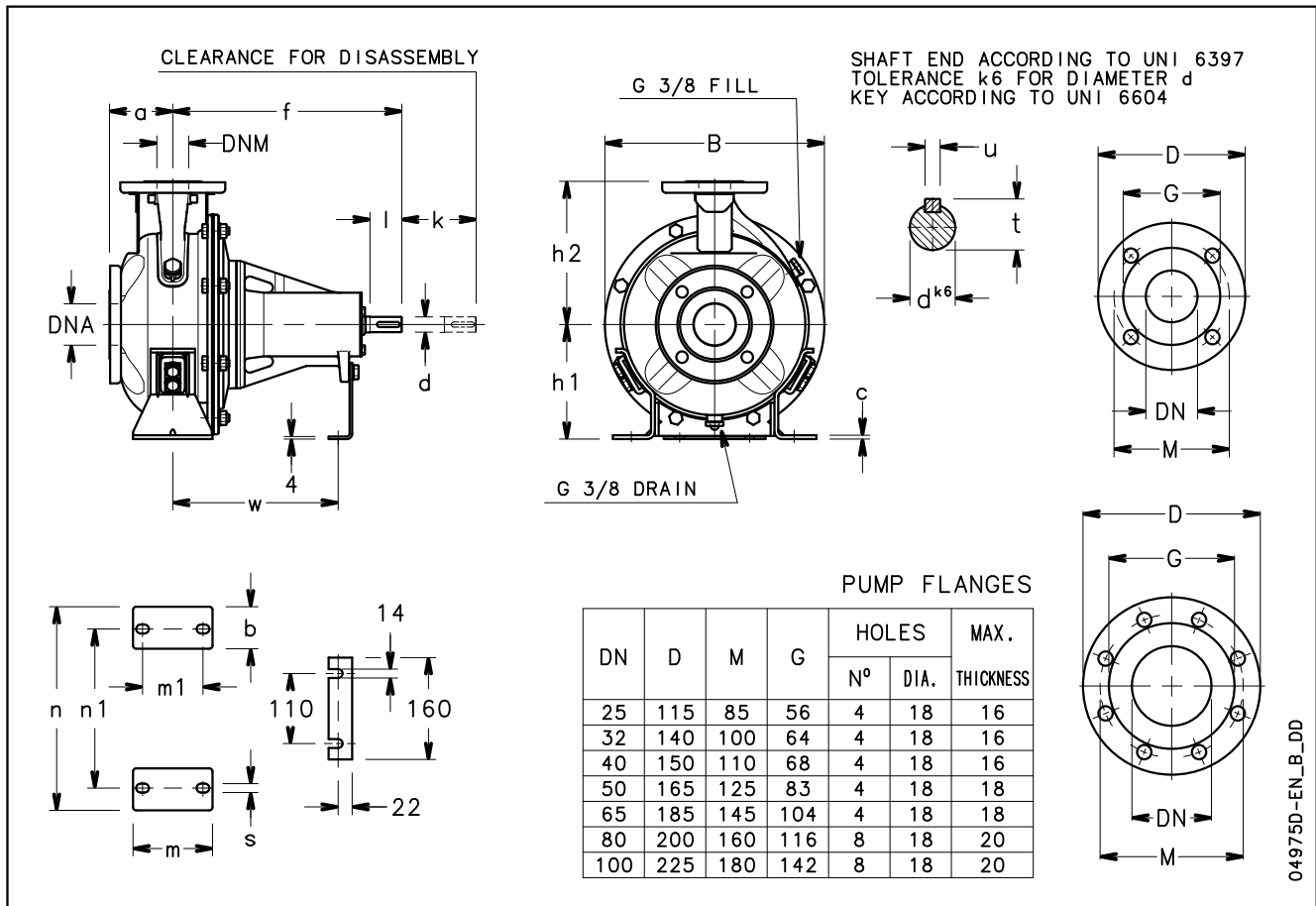

PUMP TYPE ESH (BARE SHAFT)	DIMENSIONS (mm)																				WEIGHT kg
	PUMP						SUPPORT						SHAFT						B	k	
	DNM	DNA	a	f	h1	h2	b	c	m	m1	n	n1	s	w	d	l	t	u			
25-125	25	50	80	360	112	140	47	3	100	70	190	140	14	260	24	50	27	8	218	98	14
25-160	25	50	80	360	132	160	48	3	100	70	240	190	14	260	24	50	27	8	253	98	17
25-200	25	50	80	360	160	180	47	3	100	70	240	190	14	260	24	50	27	8	284	98	20
25-250	25	50	100	360	180	225	54	6	125	95	320	250	14	260	24	50	27	8	345	98	34
32-125	32	50	80	360	112	140	47	3	100	70	190	140	14	260	24	50	27	8	218	98	14
32-160	32	50	80	360	132	160	48	3	100	70	240	190	14	260	24	50	27	8	253	98	17
32-200	32	50	80	360	160	180	47	3	100	70	240	190	14	260	24	50	27	8	284	98	20
32-250	32	50	100	360	180	225	54	6	125	95	320	250	14	260	24	50	27	8	345	98	34
40-125	40	65	80	360	112	140	47	3	100	70	210	160	14	260	24	50	27	8	218	100	16
40-160	40	65	80	360	132	160	48	3	100	70	240	190	14	260	24	50	27	8	253	100	18
40-200	40	65	100	360	160	180	50	3	100	70	265	212	14	260	24	50	27	8	284	100	20
40-250	40	65	100	360	180	225	54	6	125	95	320	250	14	260	24	50	27	8	345	107	33
50-125	50	65	100	360	132	160	48	3	100	70	240	190	14	260	24	50	27	8	253	104	17
50-160	50	65	100	360	160	180	48	3	100	70	265	212	14	260	24	50	27	8	253	104	24
50-200	50	65	100	360	160	200	40	6	100	70	265	212	14	260	24	50	27	8	310	104	30
50-250	50	65	100	360	180	225	54	6	125	95	320	250	14	260	24	50	27	8	345	107	37
65-160	65	80	100	360	160	200	48	6	125	95	280	212	14	260	24	50	27	8	310	130	31
65-200	65	80	100	360	180	225	65	15	125	95	320	250	14	260	24	50	27	8	310	130	42
65-250	65	80	100	470	200	250	80	18	160	120	360	280	18	340	32	80	35	10	345	140	55
80-160	80	100	125	360	180	225	54	6	125	95	320	250	14	260	24	50	27	8	345	160	37
80-200	80	100	125	470	180	250	65	15	125	95	345	280	14	340	32	80	35	10	345	160	55
80-250	80	100	125	470	200	280	80	18	160	120	400	315	18	340	32	80	35	10	383	160	67

ACCESSORIES

ESH SERIES - ATEX VERSION FLEXIBLE COUPLING DIMENSIONS

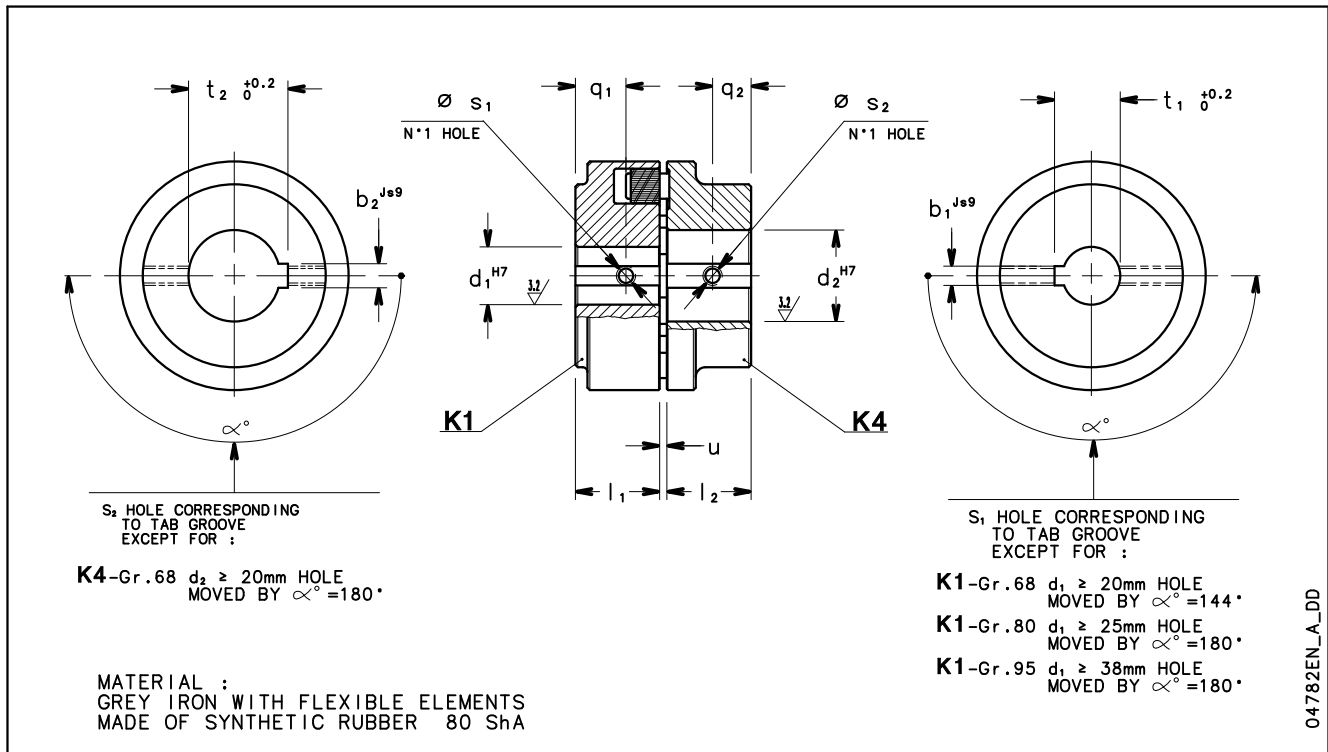

REF.	DENOMINATION	DIMENSIONS (mm)												
		K1						K4						
		PUMP-SIDE HALF COUPLING						MOTOR-SIDE HALF COUPLING						
SIZE x d_1 x d_2	d_1^{H7}	l_1	b_1^{js9}	$t_{10}^{+0.2}$	s_1	q_1	u	d_2^{H7}	l_2	b_2^{js9}	$t_{20}^{+0.2}$	s_2	q_2	
A1	B 68 x 24 x 14	24	20	8	27,3	M6	10	2÷4	14	20	5	16,3	M6	8
A2	B 68 x 24 x 19	24	20	8	27,3	M6	10	2÷4	19	20	6	21,8	M6	8
A3	B 68 x 24 x 24	24	20	8	27,3	M6	10	2÷4	24	20	8	27,3	M6	8
B1	B 80 x 24 x 28	24	30	8	27,3	M6	19	2÷4	28	30	8	31,3	M6	12
C1	B 95 x 24 x 38	24	35	8	27,3	M6	20	2÷4	38	35	10	41,3	M6	15
C2	B 95 x 24 x 42	24	35	8	27,3	M6	20	2÷4	42	35	12	45,3	M6	15
C3	B 95 x 32 x 28	32	35	10	35,3	M6	20	2÷4	28	35	8	31,3	M6	15
C4	B 95 x 32 x 38	32	35	10	35,3	M6	20	2÷4	38	35	10	41,3	M6	15
C5	B 95 x 32 x 42	32	35	10	35,3	M6	20	2÷4	42	35	12	45,3	M6	15
D1	B 110 x 24 x 48	24	40	8	27,3	M6	22	2÷4	48	40	14	51,8	M6	18
D2	B 110 x 32 x 48	32	40	10	35,3	M6	22	2÷4	48	40	14	51,8	M6	18
E2	B 125 x 24 x 55	24	50	8	27,3	M8	30	2÷4	55	50	16	59,3	M8	20
E1	B 125 x 32 x 55	32	50	10	35,3	M8	30	2÷4	55	50	16	59,3	M8	20
F1	B 140 x 32 x 60	32	55	10	35,3	M8	13	2÷4	60	55	18	64,4	M8	22
G1	B 160 x 32 x 65	32	60	10	35,3	M10	13	2÷6	65	60	18	69,4	M10	25

shf-giunto-elastico_EX2-en_a_td

ESHS 25 ÷ 80 SERIES, 2 - 4 POLES, AT 50 Hz SHIM FOR MOTOR FEET

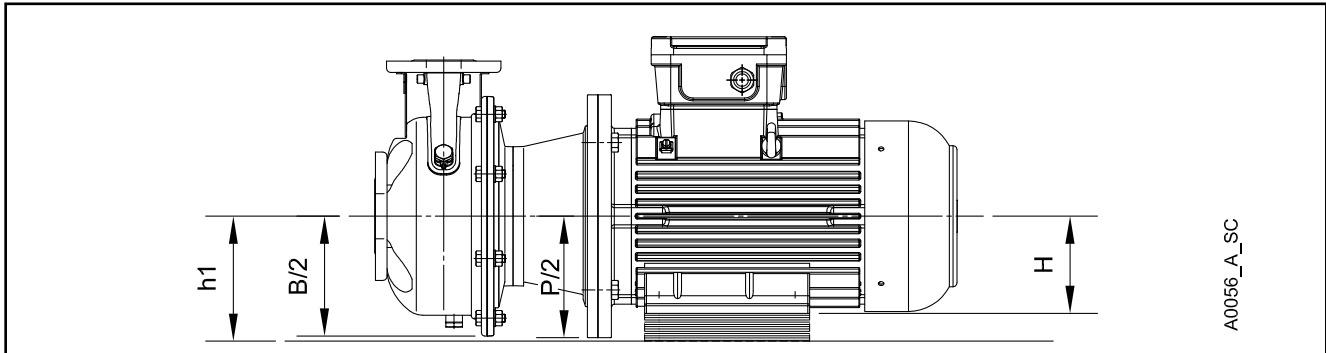

A0056_A_SC

PUMP TYPE ESHS..2...EX2	DIMENSIONS (mm)				SHIM* CODE Motor
	PUMP h1	MOTOR P/2 B/2 H			
25-125/11Y/C	160	100	110	80	4 x 161402760
25-125/11/C	160	100	110	80	4 x 161402760
25-160/22Y/C	160	100	127	90	4 x 161402740
25-160/22/C	160	100	127	90	4 x 161402740
25-200/30/C	160	125	143	100	4 x 161403010
25-200/40/C	160	125	143	112	4 x 161402990
25-250/55/C	180	150	173	132	4 x 161402990
25-250/75/C	180	150	173	132	4 x 161402990
25-250/110/C	180	175	173	160	2 x 161407670
32-125/11Y/C	112	100	110	80	2 x 161404780
32-125/11/C	112	100	110	80	2 x 161404780
32-160/22Y/C	132	100	127	90	2 x 161402400 + 2 x 161402340
32-160/22/C	132	100	127	90	2 x 161402400 + 2 x 161402340
32-200/30/C	160	125	143	100	4 x 161403010
32-200/40/C	160	125	143	112	2 x 161402990
32-250/55/C	180	150	173	132	4 x 161402990
32-250/75/C	180	150	173	132	4 x 161402990
32-250/110/C	180	175	173	160	2 x 161407670
40-125/11/C	112	100	110	80	2 x 161404780
40-125/15/C	112	100	110	90	2 x 161402320 + 2 x 161402340
40-125/22/C	112	100	110	90	2 x 161402320 + 2 x 161402340
40-160/40Y/C	132	125	127	112	2 x 161402380
40-160/55Y/C	160	150	127	132	2 x 161402440 + 2 x 161402460
40-200/75Y/C	160	150	143	132	2 x 161402440 + 2 x 161402460
40-200/110Y/C	180	175	143	160	2 x 161407670
40-250/110A/C	180	175	173	160	2 x 161407670
40-250/150Y/C	180	175	173	160	2 x 161407670
40-250/150/C	180	175	173	160	2 x 161407670
50-125/22/C	132	100	127	90	2 x 161402400 + 2 x 161402340
50-125/30/C	132	125	127	100	2 x 161402360 + 2 x 161402380
50-125/55Y/C	160	150	127	132	2 x 161402440 + 2 x 161402460
50-160/75Y/C	160	150	127	132	2 x 161402440 + 2 x 161402460
50-160/75/C	160	150	127	132	2 x 161402440 + 2 x 161402460
50-200/110A/C	180	175	155	160	2 x 161407670
50-200/150Y/C	180	175	155	160	2 x 161407670
50-250/150/C	180	175	173	160	2 x 161407670
50-250/185/C	180	175	173	160	2 x 161407670
50-250/220/C	225	200	173	200	2 x 161407650
65-160/40/C	160	125	155	112	4 x 161402990
65-160/55/C	160	150	155	132	2 x 161402440 + 2 x 161402460
65-160/75/C	160	150	155	132	2 x 161402440 + 2 x 161402460
65-160/110A/C	180	175	155	160	2 x 161407670
65-160/110/C	180	175	155	160	2 x 161407670
65-200/150/C	180	175	155	160	2 x 161407670
65-200/185/C	180	175	155	160	2 x 161407670
65-200/220/C	225	200	155	200	2 x 161407650
80-160/150Y/C	180	175	173	160	2 x 161407670
80-160/150/C	180	175	173	160	2 x 161407670
80-160/185/C	180	175	173	160	2 x 161407670
80-200/300Y/C	225	200	173	200	2 x 161407650

PUMP TYPE ESHS..4...EX2	DIMENSIONS (mm)				SHIM* CODE Motor
	PUMP h1	P/2	B/2	H	
25-250/07/C	180	100	173	80	4 x 161402970
25-250/11/C	180	100	173	90	4 x 161402950
25-250/15/C	180	100	173	90	4 x 161402950
32-250/07/C	180	100	173	80	4 x 161402970
32-250/11/C	180	100	173	90	4 x 161402950
32-250/15/C	180	100	173	90	4 x 161402950
40-200/07/C	160	100	143	80	4 x 161402760
40-200/11/C	160	100	143	90	4 x 161402740
40-250/15Y/C	180	100	173	90	4 x 161402950
40-250/15/C	180	100	173	90	4 x 161402950
40-250/22/C	180	125	173	100	4 x 161402760
50-160/07/C	160	100	127	80	4 x 161402760
50-160/11/C	160	100	127	90	4 x 161402740
50-200/11/C	160	100	155	90	4 x 161402740
50-200/15/C	160	100	155	90	4 x 161402740
50-250/22A/C	180	125	173	100	4 x 161402760
50-250/22/C	180	125	173	100	4 x 161402760
50-250/30/C	180	125	173	100	4 x 161402760
65-160/07Y/C	160	100	155	80	4 x 161402760
65-160/07/C	160	100	155	80	4 x 161402760
65-160/11A/C	160	100	155	90	4 x 161402740
65-160/11/C	160	100	155	90	4 x 161402740
65-160/15/C	160	100	155	90	4 x 161402740
65-200/22Y/C	180	125	155	100	4 x 161402760
65-200/22/C	180	125	155	100	4 x 161402760
65-200/30/C	180	125	155	100	4 x 161402760
65-250/40/C	200	125	173	112	4 x 161403130
65-250/55/C	200	150	173	132	4 x 161403030
80-160/15/C	180	100	173	90	4 x 161402950
80-160/22A/C	180	125	173	100	4 x 161402760
80-160/22/C	180	125	173	100	4 x 161402760
80-200/30/C	180	125	173	100	4 x 161402760
80-200/55Y/C	180	150	173	132	4 x 161402990
80-250/55/C	200	150	192	132	4 x 161403030
80-250/75/C	200	150	192	132	4 x 161403030
80-250/110/C	200	175	192	160	4 x 161407670

* On request.

shs-25-80sp_50_EX2-en_a_ld

In order to maintain an adequate safety standard only genuine accessories, that Xylem has certified, can be used.

ESHS 25 ÷ 80 SERIES, 2 - 4 POLES, AT 60 Hz SHIM FOR MOTOR FEET

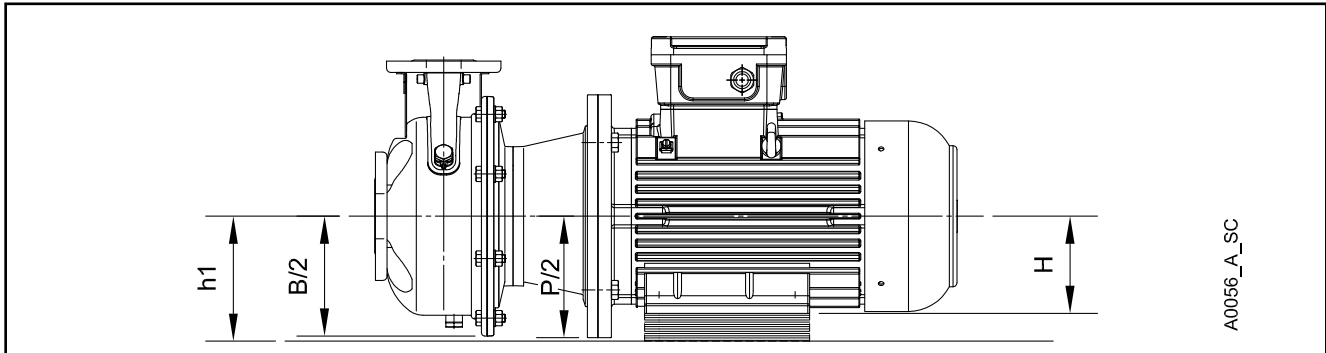

PUMP TYPE ESHS..2...EX2	DIMENSIONS (mm)				SHIM* CODE Motor
	PUMP h1	MOTOR			
		P/2	B/2	H	
25-125/11/C	160	100	110	80	4 x 161402760
25-160/22Y/C	160	100	127	90	4 x 161402740
25-160/22/C	160	100	127	90	4 x 161402740
25-200/30/C	160	125	143	100	4 x 161403010
25-200/40/C	160	125	143	112	4 x 161402990
25-250/55/C	180	150	173	132	4 x 161402990
25-250/75/C	180	150	173	132	4 x 161402990
25-250/110A/C	180	175	173	160	2 x 161407670
25-250/110/C	180	175	173	160	2 x 161407670
32-125/11/C	112	100	110	80	2 x 161404780
32-160/22Y/C	132	100	127	90	2 x 161402400 + 2 x 161402340
32-160/22/C	132	100	127	90	2 x 161402400 + 2 x 161402340
32-200/30/C	160	125	143	100	4 x 161403010
32-200/55Y/C	160	150	143	132	2 x 161402440 + 2 x 161402460
32-250/55/C	180	150	173	132	4 x 161402990
32-250/75/C	180	150	173	132	4 x 161402990
32-250/110A/C	180	175	173	160	2 x 161407670
32-250/110/C	180	175	173	160	2 x 161407670
40-125/15/C	112	100	110	90	2 x 161402320 + 2 x 161402340
40-125/22/C	112	100	110	90	2 x 161402320 + 2 x 161402340
40-160/40Y/C	132	125	127	112	2 x 161402380
40-160/40/C	132	125	127	112	2 x 161402380
40-200/75Y/C	160	150	143	132	2 x 161402440 + 2 x 161402460
40-200/75/C	160	150	143	132	2 x 161402440 + 2 x 161402460
40-250/110A/C	180	175	173	160	2 x 161407670
40-250/110/C	180	175	173	160	2 x 161407670
40-250/150/C	180	175	173	160	2 x 161407670
50-125/30/C	132	125	127	100	2 x 161402360 + 2 x 161402380
50-125/55Y/C	160	150	127	132	2 x 161402440 + 2 x 161402460
50-160/55/C	160	150	127	132	2 x 161402440 + 2 x 161402460
50-160/75/C	160	150	127	132	2 x 161402440 + 2 x 161402460
50-200/110A/C	180	175	155	160	2 x 161407670
50-200/110/C	180	175	155	160	2 x 161407670
50-250/150/C	180	175	173	160	2 x 161407670
50-250/185/C	180	175	173	160	2 x 161407670
50-250/220/C	225	200	173	200	2 x 161407650
65-160/55/C	160	150	155	132	2 x 161402440 + 2 x 161402460
65-160/75/C	160	150	155	132	2 x 161402440 + 2 x 161402460
65-160/110A/C	180	175	155	160	2 x 161407670
65-160/110/C	180	175	155	160	2 x 161407670
65-200/150/C	180	175	155	160	2 x 161407670
65-200/185/C	180	175	155	160	2 x 161407670
65-200/220/C	225	200	155	200	2 x 161407650
65-250/300/C	225	200	173	200	2 x 161407650
80-160/150/C	180	175	173	160	2 x 161407670
80-160/185/C	180	175	173	160	2 x 161407670
80-200/220/C	225	200	173	200	2 x 161407650

PUMP TYPE ESHS..4...EX2	DIMENSIONS (mm)				SHIM* CODE Motor
	PUMP h1	P/2	B/2	H	
25-250/07/C	180	100	173	80	4 x 161402970
25-250/15Y/C	180	100	173	90	4 x 161402950
25-250/15/C	180	100	173	90	4 x 161402950
32-250/07/C	180	100	173	80	4 x 161402970
32-250/11/C	180	100	173	90	4 x 161402950
32-250/15/C	180	100	173	90	4 x 161402950
40-200/07/C	160	100	143	80	4 x 161402760
40-200/11/C	160	100	143	90	4 x 161402740
40-250/11/C	180	100	173	90	4 x 161402950
40-250/15/C	180	100	173	90	4 x 161402950
40-250/22/C	180	125	173	100	4 x 161402760
50-160/07/C	160	100	127	80	4 x 161402760
50-160/11/C	160	100	127	90	4 x 161402740
50-200/15Y/C	160	100	155	90	4 x 161402740
50-200/15/C	160	100	155	90	4 x 161402740
50-250/22A/C	180	125	173	100	4 x 161402760
50-250/30Y/C	180	125	173	100	4 x 161402760
50-250/40Y/C	180	125	173	112	4 x 161403030
65-160/07/C	160	100	155	80	4 x 161402760
65-160/11A/C	160	100	155	90	4 x 161402740
65-160/15Y/C	160	100	155	90	4 x 161402740
65-160/15/C	160	100	155	90	4 x 161402740
65-200/22Y/C	180	125	155	100	4 x 161402760
65-200/22/C	180	125	155	100	4 x 161402760
65-200/30/C	180	125	155	100	4 x 161402760
65-250/40/C	200	125	173	112	4 x 161403130
65-250/55/C	200	150	173	132	4 x 161403030
80-160/22A/C	180	125	173	100	4 x 161402760
80-160/22/C	180	125	173	100	4 x 161402760
80-200/30/C	180	125	173	100	4 x 161402760
80-200/40/C	180	125	173	112	4 x 161403030
80-250/55/C	200	150	192	132	4 x 161403030
80-250/75/C	200	150	192	132	4 x 161403030
80-250/110/C	200	175	192	160	4 x 161407670

* On request.

shs-25-80sp_60_EX2-en_a_td

In order to maintain an adequate safety standard only genuine accessories, that Xylem has certified, can be used.

ESH SERIES - ATEX VERSION SHIM FOR MOTOR FEET

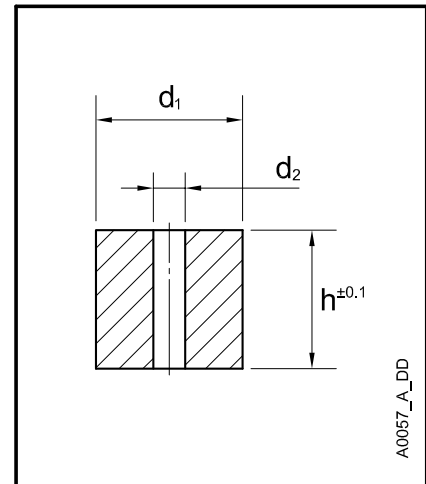
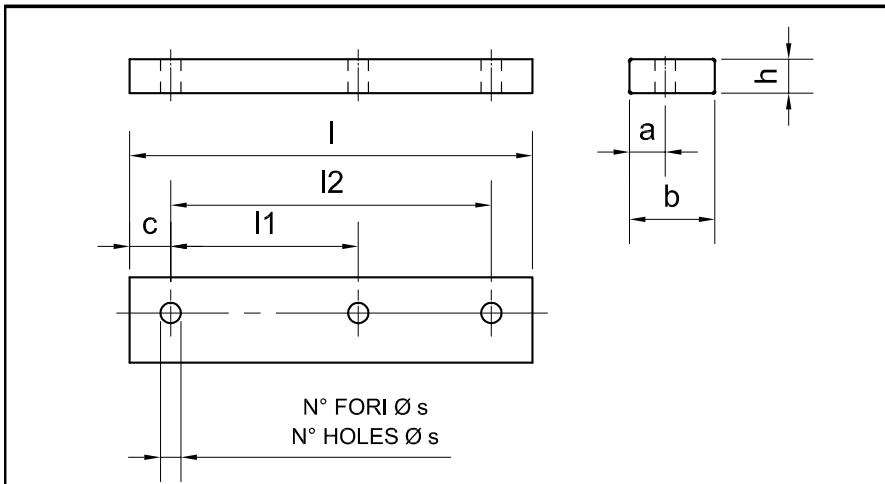

DIMENSIONS (mm)										
DENOMINATION					HOLES					
b	x	h	x	l	a	l ₁	l ₂	c	N°	$\varnothing s$
35	32	125	17	100	-	12,5	2	10		
40	10	155	20	100	125	15	3	10		
40	12	155	20	100	125	15	3	10		
40	12	180	17	140	-	20	2	14		
40	20	180	17	140	-	20	2	14		
40	30	155	20	100	125	15	3	10		
50	8	226	21	140	178	24	3	14		
50	20	226	21	140	178	24	3	14		
50	20	304	25	210	254	25	3	14		
80	25	370	33,5	305	-	32,5	2	18		

DIMENSIONS (mm)			
DENOMINATION			d ₂
d ₁	x	h	d ₂
55	70	12	12
55	80	12	12
55	90	12	12
55	100	12	12
65	48	14	14
65	60	14	14
65	68	14	14
65	88	14	14

sp-mot-shs-shf_EX2-en_a_td

SHIM FOR PUMP FEET (ESHF)

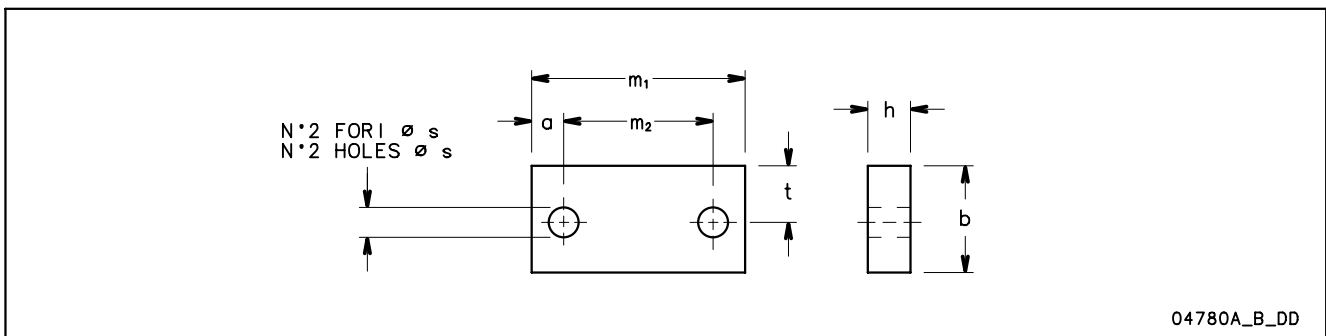

DIMENSIONS (mm)								
DESIGNATION				DIMENSIONS (mm)				
b	x	h	x	m ₁	a	m ₂	$\varnothing s$	t
40	10	160	25	110	14	16,5		
40	20	160	25	110	14	16,5		
40	25	160	25	110	14	16,5		
40	30	160	25	110	14	16,5		
70	20	125	15	95	14	37,5		
80	10	160	20	120	18	42,5		
80	25	160	20	120	18	42,5		
80	30	160	20	120	18	42,5		

sp-pompa-shf-en_b_td

In order to maintain an adequate safety standard only certified Xylem Accessories can be used.

REPORTS AND DECLARATIONS

REPORTS AND DECLARATIONS

i) Test reports

a) Factory Test Report

- Test report compiled at the end of the assembly line, including flow-head performance test (ISO 9906:2012 – Grade 3B) and hydrostatic pressure test.

b) Audit Test Report

- Test report for electric pumps compiled in the test room, comprising flow-head-pump input-pump efficiency performance test (according to ISO 9906:2012)

c) NPSH Test Report

- Test report for electric pumps compiled in the test room, comprising flow-NPSH performance test (according to ISO 9906:2012)

d) Noise Test Report

- Report indicating sound pressure and power measurements (EN ISO 20361, EN ISO 11203, EN ISO 4871)

e) Vibration Test Report

(unavailable for submerged or submergible pumps)

- Report indicating vibration measurements (ISO 10816-1)

ii) Declaration of product conformity with the technical requirements indicated in the order

a) EN 10204:2004 - type 2.1

- does not include test results on supplied or similar products.

b) EN 10204:2004 - type 2.2

- includes test results (materials certificates) on similar products.

iii) Issue of a further EC Declaration of Conformity,

- in addition to the one accompanying the product, it comprises references to European law and the main technical standards (e.g.: MD 2006/42/EC, EMCD 2004/108/EC, ErP 2009/125/EC).

N.B.: if the request is made after receipt of the product, communicate the code (name) and serial number (date + progressive number).

iv) Manufacturer's declaration of conformity

- relative to one of more types of products without indicating specific codes and serial numbers.

v) Other certificates and/or documentation on request

- subject to availability or feasibility.

vi) Duplication of certificates and/or documentation on request

- subject to availability or feasibility.

TECHNICAL APPENDIX

NPSH

The minimum operating values that can be reached at the pump suction end are limited by the onset of cavitation.

Cavitation is the formation of vapour-filled cavities within liquids where the pressure is locally reduced to a critical value, or where the local pressure is equal to, or just below the vapour pressure of the liquid.

The vapour-filled cavities flow with the current and when they reach a higher pressure area the vapour contained in the cavities condenses. The cavities collide, generating pressure waves that are transmitted to the walls. These, being subjected to stress cycles, gradually become deformed and yield due to fatigue. This phenomenon, characterized by a metallic noise produced by the hammering on the pipe walls, is called incipient cavitation.

The damage caused by cavitation may be magnified by electrochemical corrosion and a local rise in temperature due to the plastic deformation of the walls. The materials that offer the highest resistance to heat and corrosion are alloy steels, especially austenitic steel. The conditions that trigger cavitation may be assessed by calculating the total net suction head, referred to in technical literature with the acronym NPSH (Net Positive Suction Head).

The NPSH represents the total energy (expressed in m.) of the liquid measured at suction under conditions of incipient cavitation, excluding the vapour pressure (expressed in m.) that the liquid has at the pump inlet.

To find the static height h_z at which to install the machine under safe conditions, the following formula must be verified:

$$h_p + h_z \geq (NPSH_r + 0.5) + h_f + h_{pv} \quad \textcircled{1}$$

where:

- h_p** is the absolute pressure applied to the free liquid surface in the suction tank, expressed in m. of liquid; h_p is the quotient between the barometric pressure and the specific weight of the liquid.
- h_z** is the suction lift between the pump axis and the free liquid surface in the suction tank, expressed in m.; h_z is negative when the liquid level is lower than the pump axis.
- h_f** is the flow resistance in the suction line and its accessories, such as: fittings, foot valve, gate valve, elbows, etc.
- h_{pv}** is the vapour pressure of the liquid at the operating temperature, expressed in m. of liquid. h_{pv} is the quotient between the P_v vapour pressure and the liquid's specific weight.
- 0,5** is the safety factor.

The maximum possible suction head for installation depends on the value of the atmospheric pressure (i.e. the elevation above sea level at which the pump is installed) and the temperature of the liquid.

To help the user, with reference to water temperature (4° C) and to the elevation above sea level, the following tables show the drop in hydraulic pressure head in relation to the elevation above sea level, and the suction loss in relation to temperature.

Water temperature (°C)	20	40	60	80	90	110	120
Suction loss (m)	0,2	0,7	2,0	5,0	7,4	15,4	21,5

Elevation above sea level (m)	500	1000	1500	2000	2500	3000
Suction loss (m)	0,55	1,1	1,65	2,2	2,75	3,3

Friction loss is shown in the tables Flow Resistance of this catalogue. To reduce it to a minimum, especially in cases of high suction head (over 4-5 m.) or within the operating limits with high flow rates, we recommend using a suction line having a larger diameter than that of the pump's suction port. It is always a good idea to position the pump as close as possible to the liquid to be pumped.

Make the following calculation:

Liquid: water at ~15°C $\gamma = 1 \text{ kg/dm}^3$

Flow rate required: 25 m³/h

Head for required delivery: 70 m.

Suction lift: 3,5 m.

The selection is an 33SV3G075T pump whose NPSH required value is, at 25 m³/h, of 2 m.

For water at 15 °C

$$h_p = P_a / \gamma = 10,33\text{m}, h_{pv} = P_v / \gamma = 0,174\text{m} (0,01701 \text{ bar})$$

The H_f flow resistance in the suction line with foot valves is ~ 1,2 m.

By substituting the parameters in formula $\textcircled{1}$ with the numeric values above, we have:

$$10,33 + (-3,5) \geq (2 + 0,5) + 1,2 + 0,17$$

from which we have: 6,8 > 3,9

The relation is therefore verified.

VAPOUR PRESSURE

VAPOUR PRESSURE p_s AND ρ DENSITY OF WATER TABLE

t	T	p_s	ρ	t	T	p_s	ρ	t	T	p_s	ρ
°C	K	bar	kg/dm ³	°C	K	bar	kg/dm ³	°C	K	bar	kg/dm ³
0	273,15	0,00611	0,9998	55	328,15	0,15741	0,9857	120	393,15	1,9854	0,9429
1	274,15	0,00657	0,9999	56	329,15	0,16511	0,9852	122	395,15	2,1145	0,9412
2	275,15	0,00706	0,9999	57	330,15	0,17313	0,9846	124	397,15	2,2504	0,9396
3	276,15	0,00758	0,9999	58	331,15	0,18147	0,9842	126	399,15	2,3933	0,9379
4	277,15	0,00813	1,0000	59	332,15	0,19016	0,9837	128	401,15	2,5435	0,9362
5	278,15	0,00872	1,0000	60	333,15	0,1992	0,9832	130	403,15	2,7013	0,9346
6	279,15	0,00935	1,0000	61	334,15	0,2086	0,9826	132	405,15	2,867	0,9328
7	280,15	0,01001	0,9999	62	335,15	0,2184	0,9821	134	407,15	3,041	0,9311
8	281,15	0,01072	0,9999	63	336,15	0,2286	0,9816	136	409,15	3,223	0,9294
9	282,15	0,01147	0,9998	64	337,15	0,2391	0,9811	138	411,15	3,414	0,9276
10	283,15	0,01227	0,9997	65	338,15	0,2501	0,9805	140	413,15	3,614	0,9258
11	284,15	0,01312	0,9997	66	339,15	0,2615	0,9799	145	418,15	4,155	0,9214
12	285,15	0,01401	0,9996	67	340,15	0,2733	0,9793	155	428,15	5,433	0,9121
13	286,15	0,01497	0,9994	68	341,15	0,2856	0,9788	160	433,15	6,181	0,9073
14	287,15	0,01597	0,9993	69	342,15	0,2984	0,9782	165	438,15	7,008	0,9024
15	288,15	0,01704	0,9992	70	343,15	0,3116	0,9777	170	443,15	7,920	0,8973
16	289,15	0,01817	0,9990	71	344,15	0,3253	0,9770	175	448,15	8,924	0,8921
17	290,15	0,01936	0,9988	72	345,15	0,3396	0,9765	180	453,15	10,027	0,8869
18	291,15	0,02062	0,9987	73	346,15	0,3543	0,9760	185	458,15	11,233	0,8815
19	292,15	0,02196	0,9985	74	347,15	0,3696	0,9753	190	463,15	12,551	0,8760
20	293,15	0,02337	0,9983	75	348,15	0,3855	0,9748	195	468,15	13,987	0,8704
21	294,15	0,24850	0,9981	76	349,15	0,4019	0,9741	200	473,15	15,550	0,8647
22	295,15	0,02642	0,9978	77	350,15	0,4189	0,9735	205	478,15	17,243	0,8588
23	296,15	0,02808	0,9976	78	351,15	0,4365	0,9729	210	483,15	19,077	0,8528
24	297,15	0,02982	0,9974	79	352,15	0,4547	0,9723	215	488,15	21,060	0,8467
25	298,15	0,03166	0,9971	80	353,15	0,4736	0,9716	220	493,15	23,198	0,8403
26	299,15	0,03360	0,9968	81	354,15	0,4931	0,9710	225	498,15	25,501	0,8339
27	300,15	0,03564	0,9966	82	355,15	0,5133	0,9704	230	503,15	27,976	0,8273
28	301,15	0,03778	0,9963	83	356,15	0,5342	0,9697	235	508,15	30,632	0,8205
29	302,15	0,04004	0,9960	84	357,15	0,5557	0,9691	240	513,15	33,478	0,8136
30	303,15	0,04241	0,9957	85	358,15	0,5780	0,9684	245	518,15	36,523	0,8065
31	304,15	0,04491	0,9954	86	359,15	0,6011	0,9678	250	523,15	39,776	0,7992
32	305,15	0,04753	0,9951	87	360,15	0,6249	0,9671	255	528,15	43,246	0,7916
33	306,15	0,05029	0,9947	88	361,15	0,6495	0,9665	260	533,15	46,943	0,7839
34	307,15	0,05318	0,9944	89	362,15	0,6749	0,9658	265	538,15	50,877	0,7759
35	308,15	0,05622	0,9940	90	363,15	0,7011	0,9652	270	543,15	55,058	0,7678
36	309,15	0,05940	0,9937	91	364,15	0,7281	0,9644	275	548,15	59,496	0,7593
37	310,15	0,06274	0,9933	92	365,15	0,7561	0,9638	280	553,15	64,202	0,7505
38	311,15	0,06624	0,9930	93	366,15	0,7849	0,9630	285	558,15	69,186	0,7415
39	312,15	0,06991	0,9927	94	367,15	0,8146	0,9624	290	563,15	74,461	0,7321
40	313,15	0,07375	0,9923	95	368,15	0,8453	0,9616	295	568,15	80,037	0,7223
41	314,15	0,07777	0,9919	96	369,15	0,8769	0,9610	300	573,15	85,927	0,7122
42	315,15	0,08198	0,9915	97	370,15	0,9094	0,9602	305	578,15	92,144	0,7017
43	316,15	0,09639	0,9911	98	371,15	0,9430	0,9596	310	583,15	98,70	0,6906
44	317,15	0,09100	0,9907	99	372,15	0,9776	0,9586	315	588,15	105,61	0,6791
45	318,15	0,09582	0,9902	100	373,15	1,0133	0,9581	320	593,15	112,89	0,6669
46	319,15	0,10086	0,9898	102	375,15	1,0878	0,9567	325	598,15	120,56	0,6541
47	320,15	0,10612	0,9894	104	377,15	1,1668	0,9552	330	603,15	128,63	0,6404
48	321,15	0,11162	0,9889	106	379,15	1,2504	0,9537	340	613,15	146,05	0,6102
49	322,15	0,11736	0,9884	108	381,15	1,3390	0,9522	350	623,15	165,35	0,5743
50	323,15	0,12335	0,9880	110	383,15	1,4327	0,9507	360	633,15	186,75	0,5275
51	324,15	0,12961	0,9876	112	385,15	1,5316	0,9491	370	643,15	210,54	0,4518
52	325,15	0,13613	0,9871	114	387,15	1,6362	0,9476	374,15	647,30	221,20	0,3154
53	326,15	0,14293	0,9862	116	389,15	1,7465	0,9460				
54	327,15	0,15002	0,9862	118	391,15	1,8628	0,9445				

G-at_npsb_b.sc

FLOW RESISTANCE TABLE OF FLOW RESISTANCE IN BENDS, VALVES AND GATES

The flow resistance is calculated using the equivalent pipeline length method according to the table below:

ACCESSORY TYPE	DN											
	25	32	40	50	65	80	100	125	150	200	250	300
	Equivalent pipeline length (m)											
45° bend	0,2	0,2	0,4	0,4	0,6	0,6	0,9	1,1	1,5	1,9	2,4	2,8
90° bend	0,4	0,6	0,9	1,1	1,3	1,5	2,1	2,6	3,0	3,9	4,7	5,8
90° smooth bend	0,4	0,4	0,4	0,6	0,9	1,1	1,3	1,7	1,9	2,8	3,4	3,9
Union tee or cross	1,1	1,3	1,7	2,1	2,6	3,2	4,3	5,3	6,4	7,5	10,7	12,8
Gate valve	-	-	-	0,2	0,2	0,2	0,4	0,4	0,6	0,9	1,1	1,3
Foot check valve	1,1	1,5	1,9	2,4	3,0	3,4	4,7	5,9	7,4	9,6	11,8	13,9
Non return valve	1,1	1,5	1,9	2,4	3,0	3,4	4,7	5,9	7,4	9,6	11,8	13,9

G-a-pcv-en_b_th

The table is valid for the Hazen Williams coefficient $C=100$ (cast iron pipework);

for steel pipework, multiply the values by 1,41;

for stainless steel, copper and coated cast iron pipework, multiply the values by 1,85;

When the **equivalent pipeline length** has been determined, the flow resistance is obtained from the table of flow resistance.

The values given are guideline values which are bound to vary slightly according to the model, especially for gate valves and non-return valves, for which it is a good idea to check the values supplied by manufacturers.

VOLUMETRIC CAPACITY

Litres per minute l/min	Cubic metres per hour m ³ /h	Cubic feet per hour ft ³ /h	Cubic feet per minute ft ³ /min	Imperial gallon per minute Imp. gal/min	U.S. gallon per minute US gal/min
1,000	0,0600	2,1189	0,0353	0,2200	0,2642
16,6667	1,0000	35,3147	0,5886	3,6662	4,4029
0,4719	0,0283	1,0000	0,0167	0,1038	0,1247
28,3168	1,6990	60,0000	1,0000	6,2288	7,4805
4,5461	0,2728	9,6326	0,1605	1,0000	1,2009
3,7854	0,2271	8,0208	0,1337	0,8327	1,0000

PRESSURE AND HEAD

Newton per square metre N/m ²	kilo Pascal kPa	bar bar	Pound force per square inch psi	Metre of water m H ₂ O	Millimetre of mercury mm Hg
1,0000	0,0010	1 x 10 ⁻⁵	1,45 x 10 ⁻⁴	1,02 x 10 ⁻⁴	0,0075
1 000,0000	1,0000	0,0100	0,1450	0,1020	7,5006
1 x 10 ⁵	100,0000	1,0000	14,5038	10,1972	750,0638
6 894,7570	6,8948	0,0689	1,0000	0,7031	51,7151
9 806,6500	9,8067	0,0981	1,4223	1,0000	73,5561
133,3220	0,1333	0,0013	0,0193	0,0136	1,0000

LENGTH

Millimetre mm	Centimetre cm	Metre m	Inch in	Foot ft	Yard yd
1,0000	0,1000	0,0010	0,0394	0,0033	0,0011
10,0000	1,0000	0,0100	0,3937	0,0328	0,0109
1 000,0000	100,0000	1,0000	39,3701	3,2808	1,0936
25,4000	2,5400	0,0254	1,0000	0,0833	0,0278
304,8000	30,4800	0,3048	12,0000	1,0000	0,3333
914,4000	91,4400	0,9144	36,0000	3,0000	1,0000

VOLUME

Cubic metre m ³	Litre L	Millilitre ml	Imperial gallon imp. gal.	U.S. gallon US gal.	Cubic foot ft ³
1,0000	1 000,0000	1 x 10 ⁶	219,9694	264,1720	35,3147
0,0010	1,0000	1 000,0000	0,2200	0,2642	0,0353
1 x 10 ⁻⁶	0,0010	1,0000	2,2 x 10 ⁻⁴	2,642 x 10 ⁻⁴	3,53 x 10 ⁻⁵
0,0045	4,5461	4 546,0870	1,0000	1,2009	0,1605
0,0038	3,7854	3 785,4120	0,8327	1,0000	0,1337
0,0283	28,3168	28 316,8466	6,2288	7,4805	1,0000

TEMPERATURE

Water	Kelvin K	Celsius °C	Fahrenheit °F	$^{\circ}\text{F} = ^{\circ}\text{C} \times \frac{9}{5} + 32$ $^{\circ}\text{C} = (^{\circ}\text{F} - 32) \times \frac{5}{9}$
icing	273,1500	0,0000	32,0000	
boiling	373,1500	100,0000	212,0000	

G-at_pp-en_b_sc

Xylem |'zīləm|

- 1) The tissue in plants that brings water upward from the roots;
- 2) a leading global water technology company.

We're a global team unified in a common purpose: creating advanced technology solutions to the world's water challenges. Developing new technologies that will improve the way water is used, conserved, and reused in the future is central to our work. Our products and services move, treat, analyze, monitor and return water to the environment, in public utility, industrial, residential and commercial building services, and agricultural settings. With its October 2016 acquisition of Sensus, Xylem added smart metering, network technologies and advanced data analytics for water, gas and electric utilities to its portfolio of solutions. In more than 150 countries, we have strong, long-standing relationships with customers who know us for our powerful combination of leading product brands and applications expertise with a strong focus on developing comprehensive, sustainable solutions.

For more information on how Xylem can help you, go to xylem.com.



For information and technical support
Xylem Service Italia Srl

Via Dottor Vittorio Lombardi 14
36075 - Montecchio Maggiore (VI) - Italy
Tel. (+39) 0444 707111
Fax (+39) 0444 491043
www.lowara.com

Xylem Service Italia Srl reserves the right to make modification without prior notice.
Lowara, Xylem are trademarks of Xylem Inc. or one of its subsidiaries
© 2017 Xylem, Inc.