

Flygt 3069

Table of Contents

1	Introduction and Safety.....	3
1.1	Introduction.....	3
1.2	Safety terminology and symbols.....	3
1.3	User safety.....	4
1.4	Ex-approved products.....	4
1.5	Special hazards.....	6
1.5.1	Biological hazards.....	6
1.5.2	Wash the skin and eyes.....	6
1.6	Protecting the environment.....	6
1.7	End-of-life product disposal.....	6
1.8	Spare parts.....	7
1.9	Warranty.....	7
2	Transportation and Storage.....	8
2.1	Examine the delivery.....	8
2.1.1	Examine the package.....	8
2.1.2	Examine the unit.....	8
2.2	Transportation guidelines.....	8
2.2.1	Precautions.....	8
2.2.2	Lifting.....	8
2.3	Temperature ranges for transportation, handling and storage.....	10
2.4	Storage guidelines.....	10
3	Product Description.....	12
3.1	Pump design.....	12
3.2	Sensors and monitoring equipment.....	13
3.3	The data plate.....	14
3.4	Motor regulation.....	14
3.5	Approvals.....	15
3.5.1	Product approvals for hazardous locations.....	15
3.6	Product denomination.....	16
4	Installation.....	18
4.1	Precautions.....	18
4.1.1	Hazardous atmospheres.....	18
4.1.2	Install the pump.....	19
4.2	Make the electrical connections.....	21
4.2.1	General precautions.....	21
4.2.2	Grounding (earthing).....	23
4.2.3	Prepare the SUBCAB™ cables.....	23
4.2.4	Connect the motor cable to the pump.....	25
4.2.5	Connect the motor cable to the starter and monitoring equipment.....	25
4.2.6	Cable charts.....	26
4.3	Check the impeller rotation.....	35
5	Operation.....	36
5.1	Precautions.....	36
5.2	Estimate zinc anode replacement intervals.....	36
5.3	Start the pump.....	37

6	Maintenance.....	38
6.1	Precautions.....	38
6.2	Maintenance guidelines.....	38
6.3	Torque values.....	39
6.4	Change the oil.....	39
6.5	Service the pump.....	42
6.5.1	Inspection.....	43
6.5.2	Overhaul.....	43
6.5.3	Service in case of alarm.....	44
6.6	Replace the D-impeller.....	44
6.6.1	Remove the D-impeller.....	45
6.6.2	Install the D-impeller.....	45
6.7	Replace the F-impeller.....	46
6.7.1	Remove the F-impeller.....	47
6.7.2	Install the F-impeller.....	47
6.8	Replace the M-impeller and the cutting wheel.....	48
6.8.1	Remove the cutting wheel.....	49
6.8.2	Remove the M-impeller.....	49
6.8.3	Install the M-impeller.....	49
6.8.4	Install the cutting wheel.....	51
6.9	Replace the N-impeller.....	51
6.9.1	Remove the N-impeller.....	52
6.9.2	Install the N-impeller.....	53
7	Troubleshooting.....	57
7.1	Electrical troubleshooting.....	57
7.2	The pump does not start.....	57
7.3	The pump does not stop when a level sensor is used.....	58
7.4	The pump starts-stops-starts in rapid sequence.....	58
7.5	The pump runs but the motor protection trips.....	59
7.6	The pump delivers too little or no water.....	60
8	Technical Reference.....	61
8.1	Motor data.....	61
8.1.1	Thermal contacts, opening temperature.....	61
8.2	Application limits.....	61
8.3	Minimum permitted liquid level.....	61

1 Introduction and Safety

1.1 Introduction

EN

Purpose of the manual

The purpose of this manual is to provide the necessary information for working with the unit. Read this manual carefully before starting work.

Read and keep the manual

Save this manual for future reference, and keep it readily available at the location of the unit.

Intended use



WARNING:

Operating, installing, or maintaining the unit in any way that is not covered in this manual could cause death, serious personal injury, or damage to the equipment and the surroundings. This includes any modification to the equipment or use of parts not provided by Xylem. If there is a question regarding the intended use of the equipment, please contact a Xylem representative before proceeding.

Other manuals

See also the safety requirements and information in the original manufacturer's manuals for any other equipment furnished separately for use in this system.



1.2 Safety terminology and symbols

About safety messages

It is extremely important that you read, understand, and follow the safety messages and regulations carefully before handling the product. They are published to help prevent these hazards:



- Personal accidents and health problems
- Damage to the product and its surroundings
- Product malfunction

Hazard levels

Hazard level	Indication
 DANGER:	A hazardous situation which, if not avoided, will result in death or serious injury
 WARNING:	A hazardous situation which, if not avoided, could result in death or serious injury
 CAUTION:	A hazardous situation which, if not avoided, could result in minor or moderate injury
NOTICE:	Notices are used when there is a risk of equipment damage or decreased performance, but not personal injury.

Special symbols

Some hazard categories have specific symbols, as shown in the following table.

Electrical hazard	Magnetic fields hazard
 <p>Electrical Hazard:</p>	 <p>CAUTION:</p>

1.3 User safety

All regulations, codes, and health and safety directives must be observed.

The site

- Observe lockout and tagout procedures before starting work on the product, such as transportation, installation, maintenance, or service.
- Pay attention to the risks presented by gas and vapors in the work area.
- Always be aware of the area surrounding the equipment, and any hazards posed by the site or nearby equipment.

Qualified personnel

This product must be installed, operated, and maintained by qualified personnel only.

Protective equipment and safety devices

- Use personal protective equipment as needed. Examples of personal protective equipment include, but are not limited to, hard hats, safety goggles, protective gloves and shoes, and breathing equipment.
- Make sure that all safety features on the product are functioning and in use at all times when the unit is being operated.

1.4 Ex-approved products

Follow these special handling instructions if you have an Ex-approved unit.

Personnel requirements

These are the personnel requirements for Ex-approved products in potentially explosive atmospheres:

- All work on the product must be carried out by certified electricians and Xylem authorized mechanics. Special rules apply to installations in explosive atmospheres.
- All users must know about the risks of electric current and the chemical and physical characteristics of the gas, the vapor, or both present in hazardous areas.
- Any maintenance for Ex-approved products must conform to international and national standards (for example, IEC/EN 60079-17).

Xylem disclaims all responsibility for work done by untrained and unauthorized personnel.

Product and product handling requirements

These are the general product and product handling requirements for Ex-approved products in potentially explosive atmospheres:

- Only use the product in accordance with the approved motor data.
- The equipment must never run dry during operation. The volute must be filled with liquid during operation. Dry running during service and inspection is only permitted outside the classified area.
- Before you start work on the product, make sure that the product and the control panel are isolated from the power supply and the control circuit, so they cannot be energized.
- Do not open the product while it is energized or in an explosive gas atmosphere.

- Intrinsically safe circuits are normally required for the automatic level-control system by the level regulator if mounted in zone 0.
- Do not modify the equipment without approval from an Ex-approved Xylem representative.
- Only use original Xylem spare parts that are provided by an Ex-approved Xylem representative.
- The width of flameproof joints is more than the values specified in the tables of the EN/IEC 60079-1 standard. For information contact the manufacturer.
- The gap of flameproof joints is less than the values specified in Table 2 of the EN/IEC 60079-1 standard. For information contact the manufacturer.

ATEX and IECEx

Pump	Temperature Class	Minimum Ambient Temperature	Maximum Ambient Temperature
<ul style="list-style-type: none"> • 3069.070 • 3069.090 • 3069.190 • 3069.770 • 3069.890 	T3/T4	-20°C	40°C

FM

Pump	Temperature Class	Minimum Ambient Temperature	Maximum Ambient Temperature
<ul style="list-style-type: none"> • 3069.070 • 3069.090 • 3069.190 • 3069.770 • 3069.890 	T3/T4	-20°C	40°C

Specific conditions of use

These are the specific product and product handling requirements for Ex-approved products in potentially explosive atmospheres:

- The yield stress of fasteners must be in accordance with the approval drawing and the product specification. The material specifications must at a minimum fulfill: ISO 3506 Grade A2 Class 70
- The thermal contacts that are fitted to the stator windings must be connected correctly to a separate motor control circuit and in use. The thermal contacts shall be connected to a monitoring device, which disconnects the power supply immediately upon activation. This action prevents the rise of temperatures above the temperature value for the approval classification.
- It is NOT allowed to repair the flameproof joints.

Guidelines for compliance

Compliance is fulfilled only when you operate the unit within its intended use. Do not change the conditions of the service without the approval of an Ex-approved Xylem representative. When you install or maintain explosion proof products, always comply with the directive and applicable standards (for example, IEC/EN 60079-14).

Minimum permitted liquid level

The approval for explosion-proof products is predicated on a minimum permitted liquid level. See [Technical Reference](#) on page 61.

Monitoring equipment

For additional safety, use condition-monitoring devices. Examples of condition-monitoring devices include, but are not limited to, the following:

- Level indicators
- Temperature detectors in addition to the stator thermal detectors

Any thermal detectors or thermal protection devices delivered with the pump must be installed and in use at all times.

The site owner is responsible for selection, installation, and proper maintenance of functional monitoring equipment for motor protection.

1.5 Special hazards

1.5.1 Biological hazards

The product is designed for use in liquids that can be hazardous to your health. Observe these rules when you work with the product:

- Make sure that all personnel who may come into contact with biological hazards are vaccinated against diseases to which they may be exposed.
- Observe strict personal cleanliness.



WARNING: Biological Hazard

Infection risk. Rinse the unit thoroughly with clean water before working on it.

1.5.2 Wash the skin and eyes

Follow these procedures for chemicals or hazardous fluids that have come into contact with your eyes or your skin:

Condition	Action
Chemicals or hazardous fluids in eyes	<ol style="list-style-type: none"> 1. Hold your eyelids apart forcibly with your fingers. 2. Rinse the eyes with eyewash or running water for at least 15 minutes. 3. Seek medical attention.
Chemicals or hazardous fluids on skin	<ol style="list-style-type: none"> 1. Remove contaminated clothing. 2. Wash the skin with soap and water for at least 1 minute. 3. Seek medical attention, if necessary.

1.6 Protecting the environment

Emissions and waste disposal

Observe the local regulations and codes regarding:

- Reporting of emissions to the appropriate authorities
- Sorting, recycling and disposal of solid or liquid waste
- Clean-up of spills

Exceptional sites



CAUTION: Radiation Hazard

Do NOT send the product to Xylem if it has been exposed to nuclear radiation, unless Xylem has been informed and appropriate actions have been agreed upon.

1.7 End-of-life product disposal

Handle and dispose of all waste in compliance with local laws and regulations.

EU and UK only: Correct disposal of this product — waste electrical and electronic equipment

- EU: Directive 2012/19/EU on waste electrical and electronic equipment (WEEE)
- UK: SI 2013 No. 3113

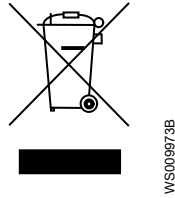

This marking on the product, accessories or literature indicates that the product should not be disposed of with other waste at the end of its working life.

1.8 Spare parts



CAUTION:

Only use the manufacturer's original spare parts to replace any worn or faulty components. The use of unsuitable spare parts may cause malfunctions, damage, and injuries as well as void the warranty.

1.9 Warranty

For information about warranty, see the sales contract.

2 Transportation and Storage

EN

2.1 Examine the delivery

2.1.1 Examine the package

1. Examine the package for damaged or missing items upon delivery.
2. Record any damaged or missing items on the receipt and freight bill.
3. If anything is out of order, then file a claim with the shipping company.
If the product has been picked up at a distributor, make a claim directly to the distributor.

2.1.2 Examine the unit

1. Remove packing materials from the product.
Dispose of all packing materials in accordance with local regulations.
2. To determine whether any parts have been damaged or are missing, examine the product.
3. If applicable, unfasten the product by removing any screws, bolts, or straps.
Use care around nails and straps.
4. If there is any issue, then contact a sales representative.

2.2 Transportation guidelines

2.2.1 Precautions



DANGER: Crush Hazard

Moving parts can entangle or crush. Always disconnect and lock out power before servicing to prevent unexpected startup. Failure to do so could result in death or serious injury.



Position and fastening

The unit can be transported either horizontally or vertically. Make sure that the unit is correctly fastened during transportation, and cannot roll or fall over.

2.2.2 Lifting

Always inspect the lifting equipment and tackle before starting any work.



WARNING: Crush Hazard

Always lift the unit by its designated lifting points.
Use suitable lifting equipment and ensure that the product is properly harnessed.
Wear personal protective equipment.
Stay clear of cables and suspended loads.

NOTICE:

Never lift the unit by its cables or hose.

Lifting points

The following images show the lifting points for the different installation types. For more information about the installation types, see [Installation](#) on page 18.

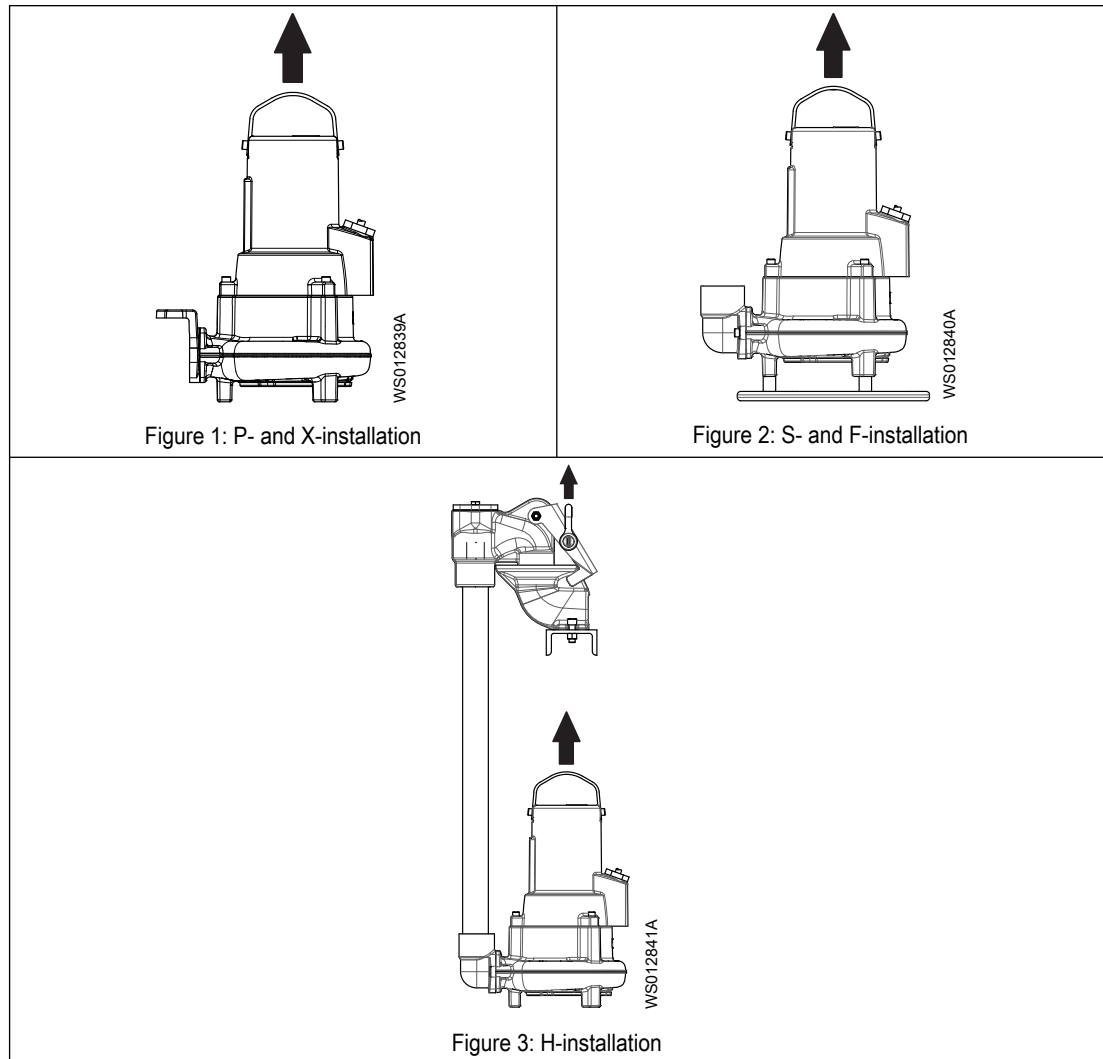

Lifting equipment

Lifting equipment is always required to handle the unit. The lifting equipment must fulfill the following requirements:

- The minimum height between the lifting hook and the floor must be sufficient to lift the unit. Contact a Xylem representative for more information.
- The lifting equipment must be able to hoist the unit straight up and down, preferably without the need for resetting the lifting hook.
- The lifting equipment must be correctly anchored and in good condition.
- The lifting equipment must support the weight of the entire assembly. Only authorized personnel may use the lifting equipment.
- The lifting equipment must be dimensioned to lift the unit with any remaining pumped media in it.
- The lifting equipment must not be oversized.



CAUTION: Crush Hazard

Improperly-dimensioned lifting equipment can lead to injury. A site-specific risk analysis must be done.

2.3 Temperature ranges for transportation, handling and storage

Handling at freezing temperature

At temperatures below freezing, the product and all installation equipment, including the lifting gear, must be handled with extreme care.

Make sure that the product is warmed up to a temperature above the freezing point before starting up. Avoid rotating the impeller/propeller by hand at temperatures below the freezing point. The recommended method to warm the unit up is to submerge it in the liquid which will be pumped or mixed.

NOTICE:

Never use a naked flame to thaw the unit.

Unit in as-delivered condition

If the unit is still in the condition in which it left the factory - all packing materials are undisturbed - then the acceptable temperature range during transportation, handling and storage is: -50°C (-58°F) to $+60^{\circ}\text{C}$ ($+140^{\circ}\text{F}$).

If the unit has been exposed to freezing temperatures, then allow it to reach the ambient temperature of the sump before operating.

Lifting the unit out of liquid

The unit is normally protected from freezing while operating or immersed in liquid, but the impeller/propeller and the shaft seal may freeze if the unit is lifted out of the liquid into a surrounding temperature below freezing.

Follow these guidelines to avoid freezing damage:

1. Empty all pumped liquid, if applicable.
2. Check all liquids used for lubrication or cooling, both oil and water-glycol mixtures, for the presence of unacceptable amounts of water. Change if needed.

Water-glycol mixtures: Units equipped with an internal closed-loop cooling system are filled with a mixture of water and 30% glycol. This mixture remains a flowing liquid at temperatures down to -13°C (9°F). Below -13°C (9°F), the viscosity increases such that the glycol mixture will lose its flow properties. However, the glycol-water mixture will not solidify completely and thus cannot harm the product.

2.4 Storage guidelines

Storage location

The product must be stored in a covered and dry location free from heat, dirt, and vibrations.

NOTICE:

Protect the product against humidity, heat sources, and mechanical damage.

NOTICE:

Do not place heavy weights on the packed product.

Long-term storage

If the unit is stored for more than six months, then the following apply:

- Before operating the unit after storage, it must be inspected. Special attention must be given to the seals and the cable entry.
- The impeller or propeller must be rotated every other month to prevent the seals from sticking together.

Packaging material stacking limit

If the packaging material has an indicated stacking limit, then it is valid for 23°C (73°F) and 50% relative humidity. Depending on the material, other temperature and humidity ranges can reduce the stacking limit.

EN

3 Product Description

Products included

Pump	D-hydraulic	F-hydraulic	M-hydraulic (Grinder)	N-hydraulic, cast iron	N-hydraulic, Hard-Iron™	N-hydraulic, stainless steel
3069.060					MT, SH	
3069.070 ¹					MT, SH	
3069.090 ¹	LT, MT, HT	LT				
3069.160				MT, SH		
3069.170			HT			
3069.180	LT, MT, HT	LT				
3069.190 ¹				MT, SH		
3069.760						MT, SH
3069.770 ¹						MT, SH
3069.890 ¹			HT			

¹ Explosion proof drive unit

Pump-specific information

For the specific weight, current, voltage, power ratings, and speed of the pump, see the data plate of the pump.

3.1 Pump design

The pump is submersible, and driven by an electric motor. For motor data, see [Technical Reference](#) on page 61.

Intended use

The product is intended for moving waste water, sludge, raw and clean water. Always follow the limits given in [Technical Reference](#) on page 61. If there is a question regarding the intended use of the equipment, please contact a local sales and service representative before proceeding.



DANGER: Explosion/Fire Hazard

Special rules apply to installations in explosive or flammable atmospheres. Do not install the product or any auxiliary equipment in an explosive zone unless it is rated explosion-proof or intrinsically-safe. If the product is rated explosion-proof or intrinsically-safe, then see the specific explosion-proof information in the safety chapter before taking any further actions.

Corrosive liquids

NOTICE:

Do NOT use the unit in highly corrosive liquids.

Pressure classes

LT	Low head
MT	Medium head
HT	High head
SH	Super high head

Parts

The information describes the product in general. The supplied product can differ on a detailed level.

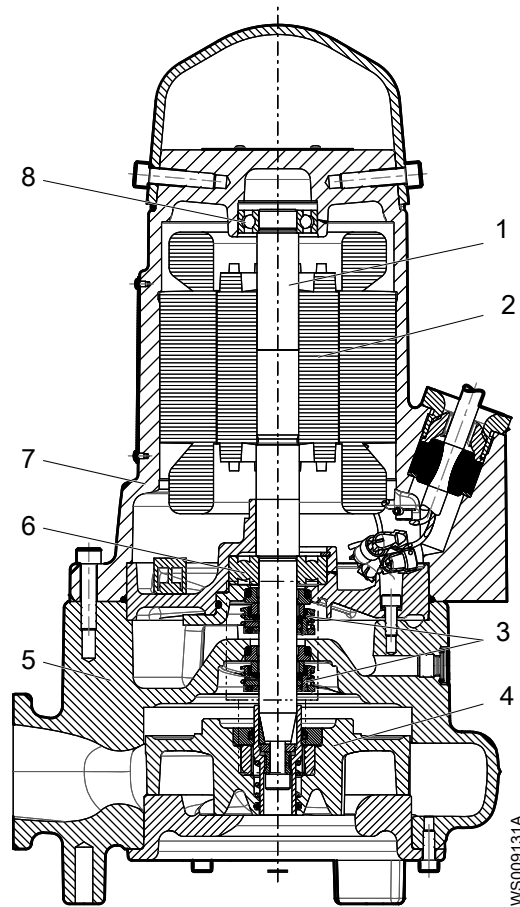

Position	Part	Description
1	Shaft	Stainless steel shaft with integrated rotor
2	Electric motor	For more information about the motor, see Motor data on page 61
3	Mechanical seal	One stationary and one rotating seal ring <ul style="list-style-type: none"> • Aluminum oxide Al_2O_3 • Carbon CSB • Corrosion-resistant cemented carbide WCCR For information, see Parts List.
4	Impeller	
5	Pump housing	The pump housing includes a coolant that lubricates and cools the seals; the housing acts as a buffer between the pumped fluid and the drive unit.
6	Main bearing	Single-row deep-groove ball bearing
7	Stator housing	The pump is cooled by the ambient liquid or air.
8	Support bearing	Single-row deep-groove ball bearing
—	Screws and nuts	Property class 80 See Torque values on page 39.

3.2 Sensors and monitoring equipment

The following applies to the monitoring equipment of the pump:

- The stator incorporates three thermal contacts connected in series that activate the alarm and stops the pump at overtemperature
- The thermal contacts open at 125°C (257°F) or 140°C (284°F). For more information, see [Technical Reference](#) on page 61.
- Ex-approved pumps must have thermal contacts connected to the control panel.
- The sensors must be connected to either the MiniCAS II monitoring equipment or an equivalent equipment.
- The monitoring equipment must be of a design that makes automatic restart impossible.

Optional sensors

FLS FLS is a miniature float switch for detection of liquid in the stator housing. Due to its design it is best suited for pumps in a vertical position. The FLS sensor is installed in the bottom of the stator housing.

3.3 The data plate

The data plate is a metal label that is located on the main body of the products. The data plate lists key product specifications. Specially approved products also have an approval plate.

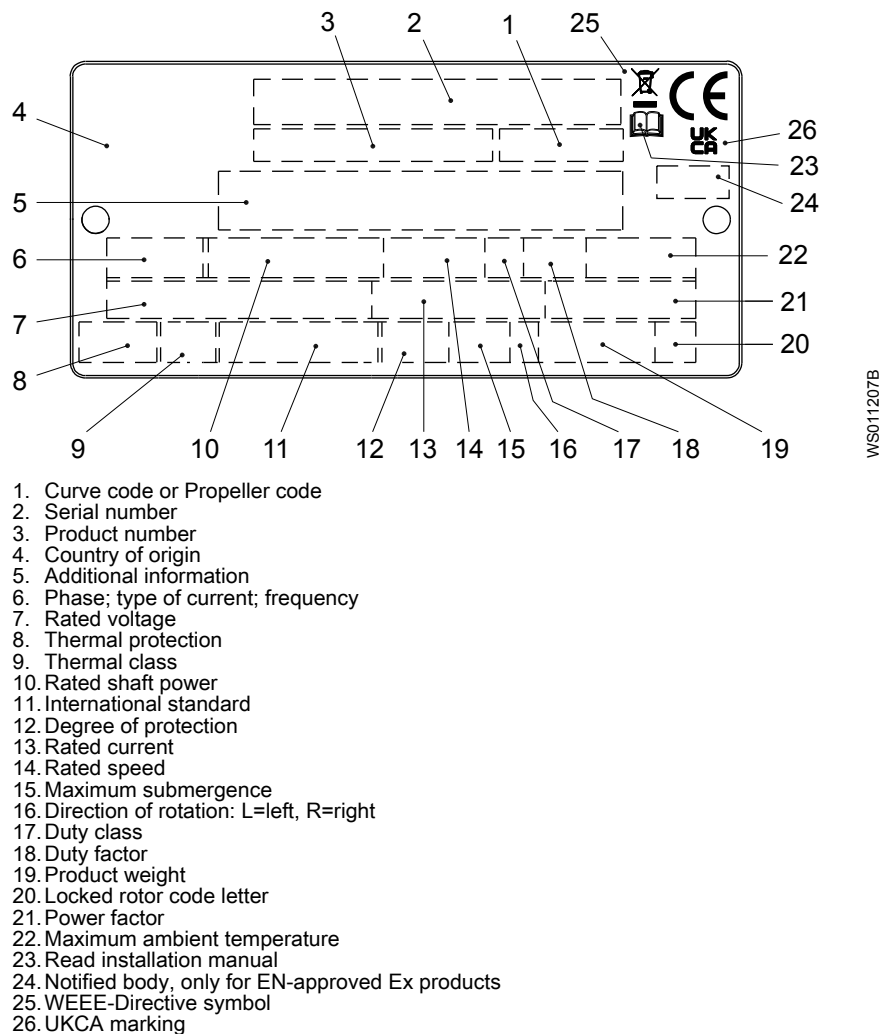

Figure 4: The data plate

3.4 Motor regulation

This product is submersible and therefore exempted from the motor efficiency requirement, in accordance with EU commission regulation 2019/1781 Article 2(2)(e).

3.5 Approvals





3.5.1 Product approvals for hazardous locations

3069

EN

This table shows product approvals for the following products:

- 3069.070
- 3069.090
- 3069.190
- 3069.770
- 3069.890

Type	Approval
European Norm (EN)	<ul style="list-style-type: none"> • ATEX Directive <ul style="list-style-type: none"> – FM18ATEX0006X • EN IEC 60079-0:2018, EN 60079-1:2014, EN ISO 80079-36:2016, EN ISO 80079-37:2016 •  II 2 G Ex db h IIB T4 Gb •  II 2 G Ex db h IIB T3 Gb
IEC	<ul style="list-style-type: none"> • IECEx scheme <ul style="list-style-type: none"> – IECEx FMG 17.0036X • IEC 60079-0:2017, IEC 60079-1:2014, ISO 80079-36:2016, ISO 80079-37:2016 • Ex db h IIB T3 Gb • Ex db h IIB T4 Gb
FM (FM Approvals)	<ul style="list-style-type: none"> • Explosion proof for use in Class I, Div. 1, Group C and D
UKEx	<ul style="list-style-type: none"> • UK SI 2016 No. 1107 <ul style="list-style-type: none"> – FM22UKEX0010X • EN IEC 60079-0:2018, EN 60079-1:2014, EN ISO 80079-36:2016, EN ISO 80079-37:2016 •  II 2 G Ex db h IIB T4 Gb •  II 2 G Ex db h IIB T3 Gb

EN approval plate

This illustration describes the EN approval plate and the information that is contained in its fields.

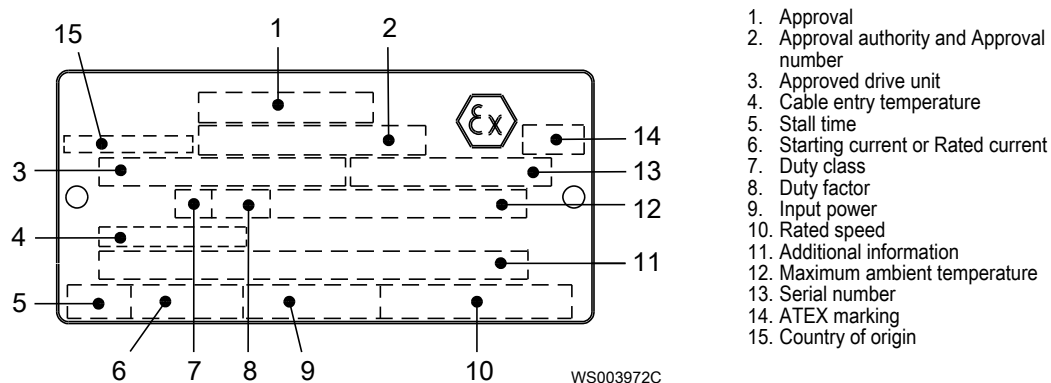

IEC approval plate

This illustration describes the IEC approval plate and the information that is contained in its fields.

International Norm; not for EU member countries.

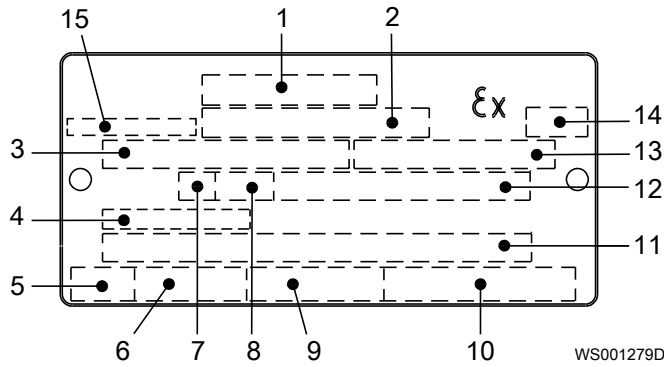

1. Approval
2. Approval authority and Approval number
3. Approved drive unit
4. Cable entry temperature
5. Stall time
6. Starting current or Rated current
7. Duty class
8. Duty factor
9. Input power
10. Rated speed
11. Additional information
12. Maximum ambient temperature
13. Serial number
14. ATEX marking
15. Country of origin

FM approval plate

This illustration describes the FM approval plate and the information that is contained in its fields.

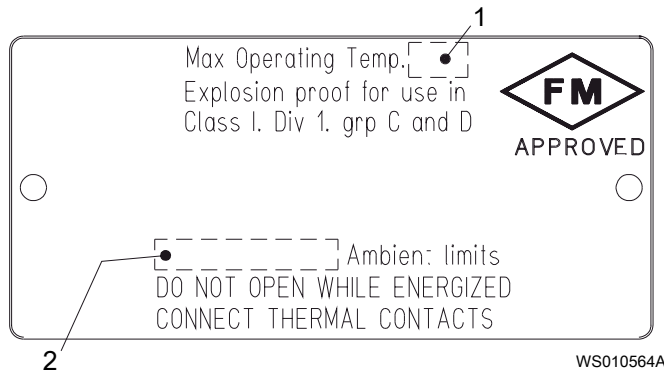

1. Temperature class
2. Maximum ambient temperature

United Kingdom: UKEx approval plate

This illustration describes the UKEx approval plate and the information that is contained in its fields.

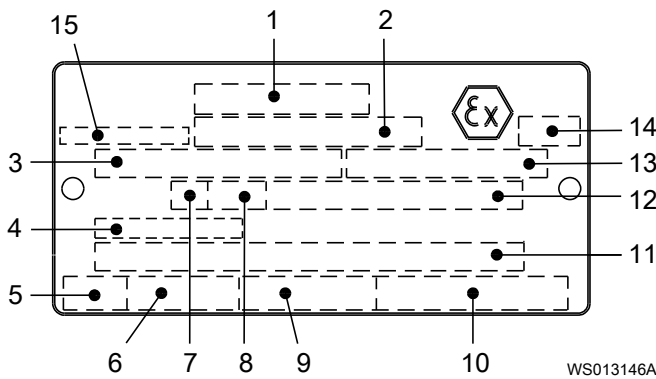

1. Approval
2. Approval authority and Approval number
3. Approved drive unit
4. Cable entry temperature
5. Stall time
6. Starting current or Rated current
7. Duty class
8. Duty factor
9. Input power
10. Rated speed
11. Additional information
12. Maximum ambient temperature
13. Serial number
14. UKEx marking
15. Country of origin

3.6 Product denomination

Reading instruction

In this section, code characters are illustrated accordingly:

X = letter

Y = digit

The different types of codes are marked up with a, b and c. Code parameters are marked up with numbers.

Codes and parameters

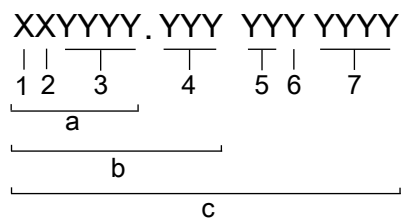

W5006265B

EN

Type of Callout	Number	Indication
Type of code	a	Sales denomination
	b	Product code
	c	Serial number
Parameter	1	Hydraulic end
	2	Type of installation
	3	Sales code
	4	Version
	5	Production year
	6	Production cycle
	7	Running number

4 Installation

4.1 Precautions



Before starting work, make sure that the safety instructions have been read and understood.

DANGER: Electrical Hazard

Before starting work on the unit, make sure that the unit and the control panel are isolated from the power supply and cannot be energized. This applies to the control circuit as well.



DANGER: Inhalation Hazard

Before entering the work area, make sure that the atmosphere contains sufficient oxygen and no toxic gases.

4.1.1 Hazardous atmospheres



DANGER: Explosion/Fire Hazard

Special rules apply to installations in explosive or flammable atmospheres. Do not install the product or any auxiliary equipment in an explosive zone unless it is rated explosion-proof or intrinsically-safe. If the product is rated explosion-proof or intrinsically-safe, then see the specific explosion-proof information in the safety chapter before taking any further actions.

General requirements

These requirements apply:

- Use the pump dimensional drawing in order to ensure proper installation.

Before installing the pump, do the following:

- Provide a suitable barrier around the work area, for example, a guard rail.
- Make sure that equipment is in place so that the unit cannot roll or fall over during the installation process.
- Check the explosion risk before you weld or use electric hand tools.
- Check that the cable and cable entry have not been damaged during transport.
- Always remove all debris and waste material from the sump, inlet piping, and discharge connection, before you install the pump.
- Always check the impeller rotation before lowering the pump into the pumped liquid.

NOTICE:

Do not run the pump dry.

NOTICE:

Never force piping to make a connection with a pump.

Authority regulation

Vent the tank of a sewage station in accordance with local plumbing codes.

Pressure restriction

The maximum working pressure must not exceed the value in the approved performance curve for the pump. A closed valve or a clogged pipe can rapidly build up the pressure. A motor protector or a relief valve on the discharge line is always recommended.

NOTICE:

Never operate the pump with the discharge line blocked, or the discharge valve closed.

Fasteners

- Only use fasteners of the correct size and material.
- Replace all corroded or damaged fasteners.
- Make sure that all the fasteners are correctly tightened and that there are no missing fasteners.

EN

4.1.2 Install the pump

These requirements and instructions only apply when the installation is made according to the dimensional drawing.

1. Run the cable so that it has no sharp bends. Make sure that it is not pinched, and cannot be sucked into the pump inlet.
2. Install the pump according to the instructions for the installation type.
Where applicable, the installation instructions are included in the mechanical accessories.
3. Connect the motor cable and the starter and monitoring equipment according to the separate instructions.

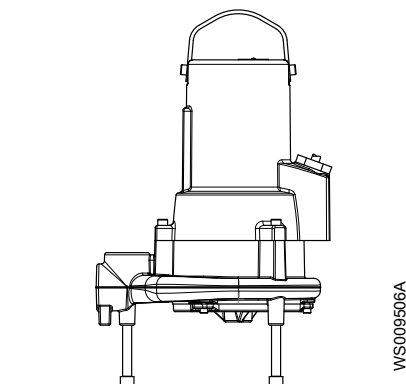
4.1.2.1 F-installation

F Free standing semipermanent, wet well arrangement where the pump is placed on a firm surface.

The pump is intended to operate completely submerged in the pumped liquid.

4.1.2.2 H-installation

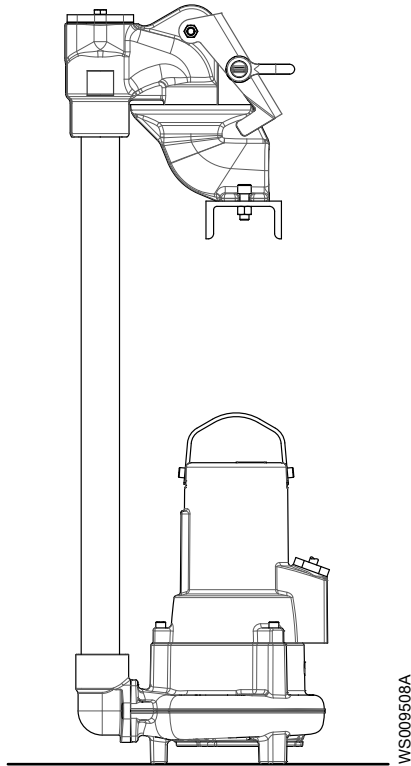

H Semipermanent, wet well quick connection suspended arrangement, incorporating integral non-return valve.

The pump is intended to operate completely submerged in the pumped liquid.

These items are required:

- Discharge connection
- Pipe

For installation instructions, see appropriate mechanical accessories.

4.1.2.3 P-installation

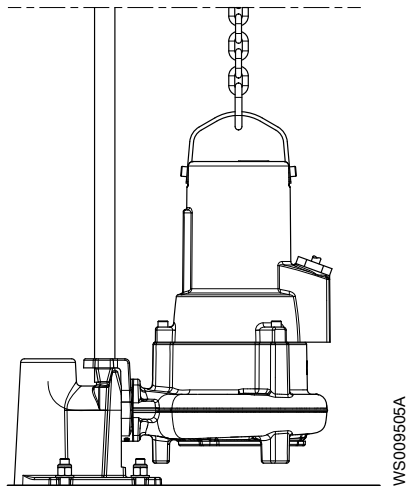

P Semipermanent, wet well arrangement with the pump installed on two guide bars. The connection to the discharge is automatic.

The pump is intended to operate completely submerged in the pumped liquid.

4.1.2.4 S-installation

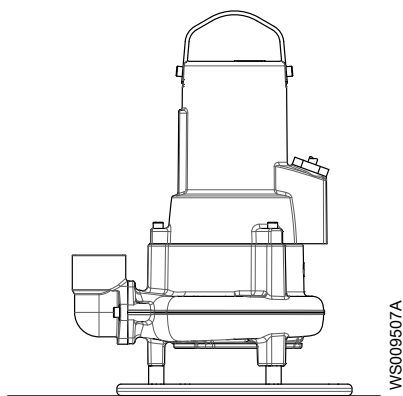

S Portable semipermanent, wet well arrangement with hose coupling or flange for connection to the discharge pipeline.

The pump is intended to operate completely submerged in the pumped liquid.

4.1.2.5 X-installation

In the X-installation, the pump has no pre-determined mechanical connection. The flange is drilled.

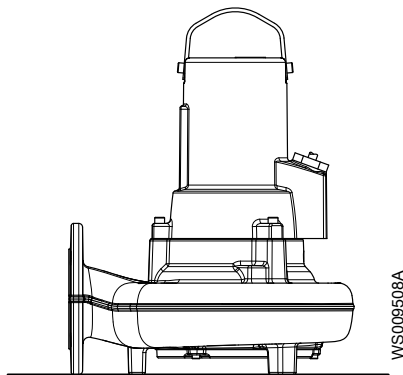

4.2 Make the electrical connections

4.2.1 General precautions



DANGER: Electrical Hazard

Before starting work on the unit, make sure that the unit and the control panel are isolated from the power supply and cannot be energized. This applies to the control circuit as well.



WARNING: Electrical Hazard

Risk of electrical shock or burn. A certified electrician must supervise all electrical work. Comply with all local codes and regulations.



WARNING: Electrical Hazard

There is a risk of electrical shock or explosion if the electrical connections are not correctly carried out, or if there is fault or damage on the product. Visually inspect equipment for damaged cables, cracked casings or other signs of damage. Make sure that electrical connections have been correctly made.

**WARNING: Crush Hazard**

Risk of automatic restart.

**CAUTION: Electrical Hazard**

Prevent cables from becoming sharply bent or damaged.

NOTICE:

Leakage into the electrical parts can cause damaged equipment or a blown fuse. Keep the cable ends dry at all times.

Requirements

These general requirements apply for the electrical installation:

- If the pump will be connected to the public mains, then the supply authority must be notified before installing the pump. When the pump is connected to the public power supply, it can cause flickering of incandescent lamps when started.
- The mains voltage and frequency must agree with the specifications on the data plate. If the pump can be connected to different voltages, then follow the specified voltage on the yellow sticker close to the cable entry.
- If the operation can be intermittent, such as S3 periodic duty, then the pump must be supplied with monitoring equipment supporting such operation.
- If stated on the data plate, then the motor is convertible between different voltages.
- The thermal contacts or thermistors must be in use.
- If the temperature of the pumped liquid is above 40°C (104°F), then do not connect the T1 and T2 leads to thermal contacts. This does not apply to Ex-versions of the product.
- For FM-approved pumps, a leakage sensor must be connected and in use to meet approval requirements.

Motor and short-circuit protection**NOTICE:**

A qualified electrician must select the size of motor protection breakers and fuses. The size must be chosen for the specific motor data such as rated current and starting current.

It is important that the short-circuit protection is not over-dimensioned. Over-dimensioned fuses or motor protection breakers decrease the protection for the motor.

- The fuse rating and the cables must be in accordance with the local rules and regulations.
- The fuses and circuit breakers must have the correct rating.
- The pump overload protection must be connected and set to the rated current.

The starting current in direct-on-line start can be up to six times higher than the rated current.

For more information, see the data plate and if applicable, the cable chart for the rated current.

Cables

When cables are installed, these requirements must be followed:

- The cables must be in good condition, not have any sharp bends, and not be pinched.
- The cables must not be damaged and must not have indentations.
- The cables must not be embossed at the cable entry.
- The cable entry seal sleeve and washers must conform to the outer diameter of the cable.

- The minimum bend radius must not be smaller than the accepted value.
- If a cable is reused, a short piece at the end must be peeled off when the cable is refitted. This action is necessary so that the seal sleeve of the cable entry does not close around the cable at the same point again. If the outer jacket of the cable is damaged, then the cable must be replaced.
Contact a sales or authorized service representative.
- The voltage drop in long cables must be considered. The rated voltage of the drive unit is the voltage that is measured at the cable connection point in the pump.
- If a variable frequency drive (VFD) is used, the screened cable must be used according to the European CE and EMC requirements. For more information, contact a sales or authorized service representative.
- The cable length must be long enough for maintenance work.
- For SUBCAB™ cables, the twisted pair copper foil must be trimmed.
- All unused conductors must be insulated.

VFD requirements

The use of an external variable frequency drive (VFD) together with the pump is only allowed when the following requirements are fulfilled:

Pump serial number, minimum	3069.xxx-221xxxx
Cable length, maximum	10 m (33 ft)
Supply voltage, maximum	400 V

4.2.2 Grounding (earthing)

Grounding (earthing) must be done in compliance with all local codes and regulations.



DANGER: Electrical Hazard

All electrical equipment must be grounded (earthed). Test the ground (earth) lead to verify that it is connected correctly and that the path to ground is continuous.



WARNING: Electrical Hazard

Risk of electrical shock. The ground (earth) lead must be sufficiently longer than the phase leads to make sure that the ground lead is the last to become disconnected if the cable is jerked loose.



WARNING: Electrical Hazard

Risk of electrical shock or burn. You must connect an additional ground- (earth-) fault protection device to the grounded (earthed) connectors if persons are likely to come into contact with liquids that are also in contact with the pump or pumped liquid.

4.2.3 Prepare the SUBCAB™ cables

This section applies to SUBCAB™ cables with twisted-pair control conductors.

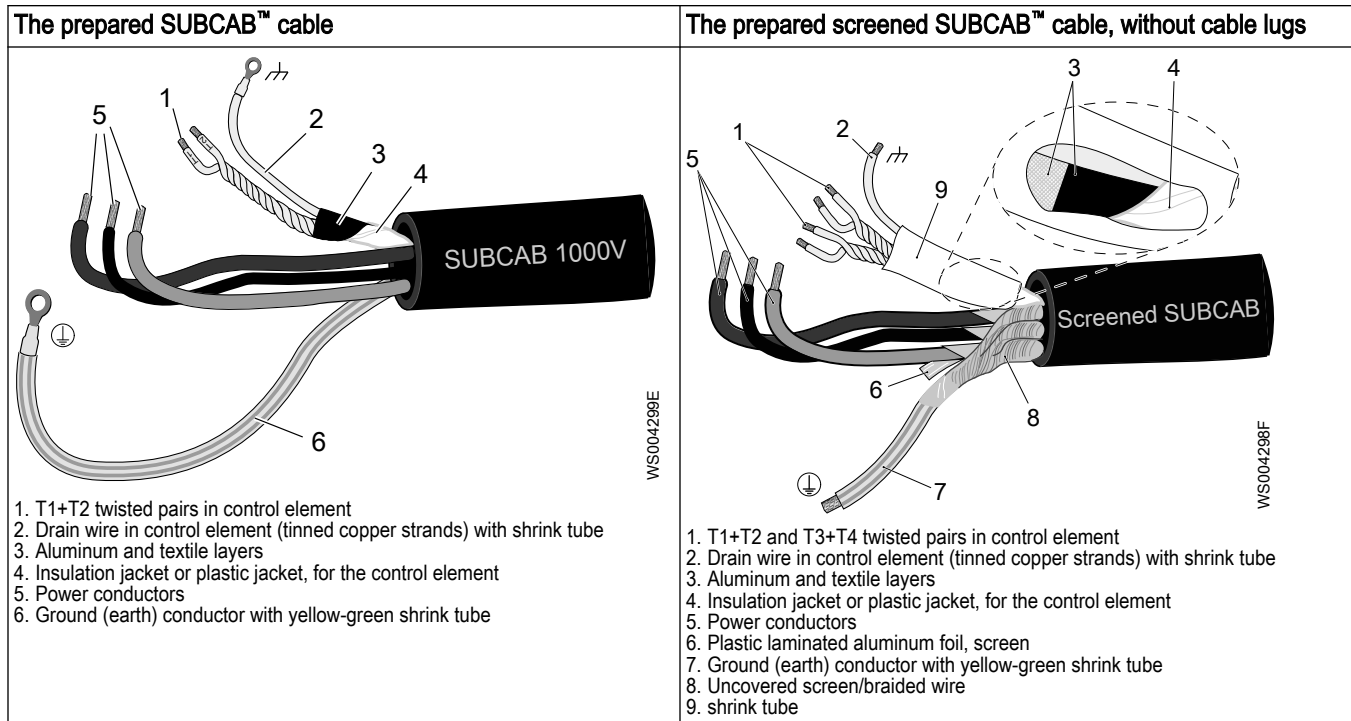

1. Peel off the outer jacket at the end of the cable.
2. Prepare the control element:
 - a) Peel the insulation jacket or plastic jacket.
 - b) Peel the aluminum and textile layers.

The aluminum foil is a conductive screen. Do not peel more than necessary, and remove the peeled foil.

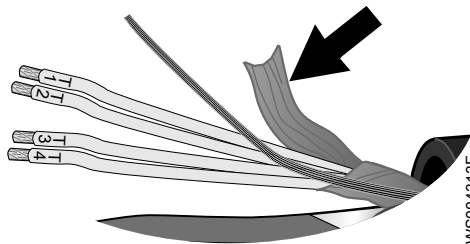

Figure 5: Aluminum foil on the control element.

- c) Put a white shrink tube over the drain wire.
 - d) Twist T1+T2 and T3+T4.
 - e) Put a shrink tube over the control element.

Make sure that the conductive aluminum foil and drain wire are covered.
3. Prepare the ground (earth) conductor of the SUBCAB™ cable:
 - a) Peel the yellow-green insulation from the ground (earth) conductor.
 - b) Check that the ground (earth) conductor is at least 10% longer than the phase conductors in the cabinet.
 - c) If applicable, put a cable lug on the ground conductor.
4. Prepare the ground (earth) conductor of the screened SUBCAB™ cable:
 - a) Untwist the screens around the power conductors.
 - b) Twist all power conductor screens together to create a ground (earth) conductor.
 - c) Put a yellow-green shrink tube over the ground (earth) conductor.

- Leave a short piece uncovered.
- d) Check that the connected ground (earth) conductor has sufficient slack. The conductor must stay connected even if the power conductors are pulled loose.
5. Prepare the power conductors:
 - a) Remove the aluminum foil around each power conductor.
 - b) Peel the insulation from each power conductor.
 6. Prepare the ends of the ground (earth) conductor, the power conductors, and the drain wire:

Connection type	Action
Screw	Fit cable lugs to the ends.
Terminal block	Fit end sleeves or leave the ends as they are.

4.2.4 Connect the motor cable to the pump

NOTICE:

Leakage into the electrical parts can cause damaged equipment or a blown fuse. Keep the end of the motor cable dry at all times.

At delivery from the factory, the motor cable is usually already connected to the pump.

1. Remove the entry gland screw from the stator housing.
 2. Detach the stator housing from the pump housing.
- The action provides access to the electrical connections.

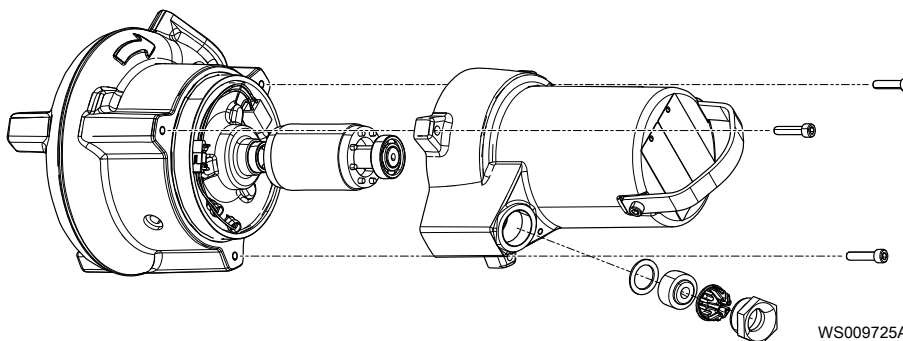

3. Check the data plate to see which connections are required for the power supply.
4. Arrange the connections in accordance with the required power supply.
5. Connect the mains leads (L1, L2, L3, and ground (earth)) according to the applicable cable chart.

The ground (earth) lead must be 160 mm (6.3 in) longer than the phase leads in the unit.
6. Make sure that the pump is correctly connected to ground (earth).
7. Make sure that any thermal contacts incorporated in the pump are properly connected.
8. Attach the stator housing to the pump housing.
9. Install the entry gland screw on the stator housing.

4.2.5 Connect the motor cable to the starter and monitoring equipment



DANGER: Explosion/Fire Hazard

Special rules apply to installations in explosive or flammable atmospheres. Do not install the product or any auxiliary equipment in an explosive zone unless it is rated explosion-proof or intrinsically-safe. If the product is rated explosion-proof or intrinsically-safe, then see the specific explosion-proof information in the safety chapter before taking any further actions.

NOTICE:

Thermal contacts must never be exposed to voltages higher than 250 V, breaking current maximum 4 A.

EN

The single phase pumps must be equipped with a starter which has start and run capacitors. A specially Flygt designed starter is required for the operation of single phase pumps. The connection of the motor cable to the starter is shown in the wiring diagram.

1. If thermal contacts are included in the pump installation, then connect the T1 and T2 control conductors to the MiniCAS II monitoring equipment.
If the temperature of the pumped liquid is above 40°C (104°F), then do not connect the T1 and T2 leads to thermal contacts. This does not apply to Ex-versions of the product.
2. Connect the mains leads (L1, L2, L3, and ground (earth)) to the starter equipment.
For information about the phase sequence and the color codes of the leads, see Cable charts.
3. Check the functionality of the monitoring equipment:
 - a) Check that the signals and the tripping function work correctly.
 - b) Check that the relays, lamps, fuses, and connections are intact.
 Replace any defective equipment.

4.2.6 Cable charts

Description

This topic contains general connection information. It also provides cable charts that show connection alternatives for use with different cables and power supply.

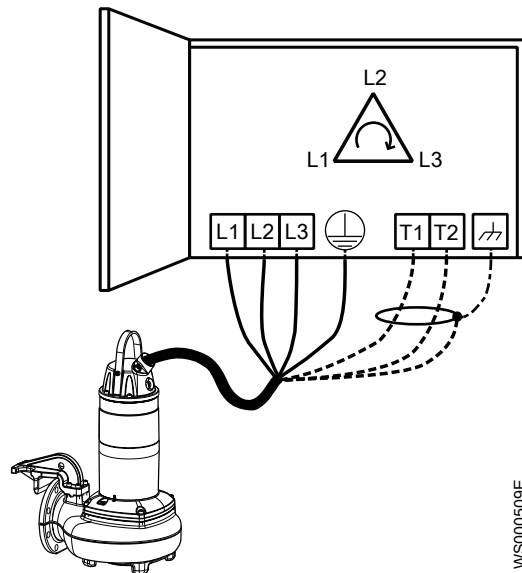
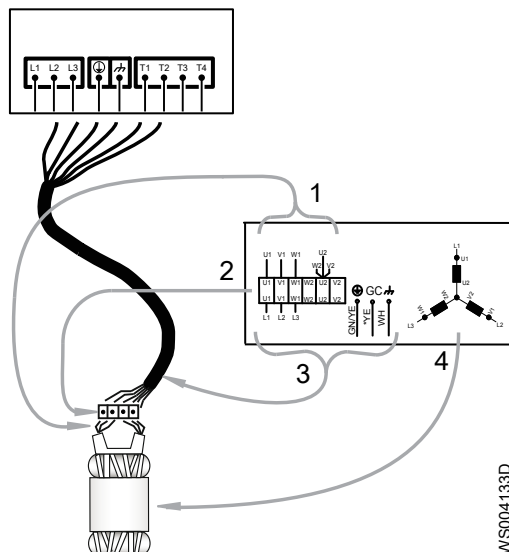

Figure 6: Phase sequence

Connection locations

The figures in this section illustrate how to interpret the connection strip symbols.



1. Stator leads
2. Terminal board
3. Power cable leads
4. Stator (internal connection illustrated)

WS0004133D

EN

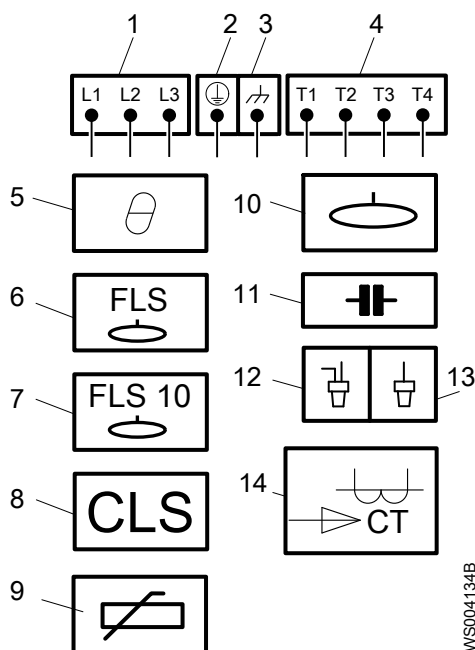

1. Starter equipment and mains leads (L1, L2, L3)
2. Ground (earth)
3. Functional ground
4. Control leads (T1, T2, T3, T4)
5. Thermal contact
6. FLS
7. FLS 10
8. CLS
9. Thermistor
10. Level sensor
11. Capacitor
12. Crimp connection
13. Crimp isolation
14. Current transformer

WS0004134B

Color code standard

Code	Description
BN	Brown
BK	Black
WH	White
OG	Orange
GN	Green
GNYE	Green-Yellow
RD	Red
GY	Grey
BU	Blue
YE	Yellow

4.2.6.1 Colors and markings of leads

Motor connection		Mains		SUBCAB 7GX Screenflex 7GX	SUBCAB 4GX Screenflex 4GX	SUBCAB AWG	SUBCAB Screened
Colours and marking of main leads		1~	3~				
COLOUR STANDARD BN=Brown BK=Black WH=White OG=Orange GN=Green GN/YE=Green-Yellow RD=Red GY=Grey BU=Blue YE=Yellow *SUBCAB AWG ** Ground Conductor is stranded around cores GC=Ground Check 863 17 00 (REV 2)	STATOR LEADS U1,U5 RD U2,U6 GN V1,V5 BN V2,V6 BU W1,W5 YE W2,W6 BK T1,T2 WH/YE	1	L1	BK 1	BN	RD	BN
		2	L2	BK 2	BK	BK	BK
		3	L3	BK 3	GY	WH	GY
			L1	BK 4	-	-	-
			L2	BK 5	-	-	-
			L3	BK 6	-	-	-
				GN/YE	GN/YE	GN/YE	**Screen/PE from cores
				Screen (WH)	Screen (WH)	-	Screen (WH)
			GC			YE	-

WS004125E

Figure 7: 3-phase and 1-phase without built-in starter

For markings on sensor leads, see [Sensors connection](#) on page 33.

4.2.6.2 Connections included

- [3-phase connection](#) on page 28
- [1-phase connection](#) on page 32
- [Sensors connection](#) on page 33
- [Screened cable connection](#) on page 33

4.2.6.3 3-phase connection

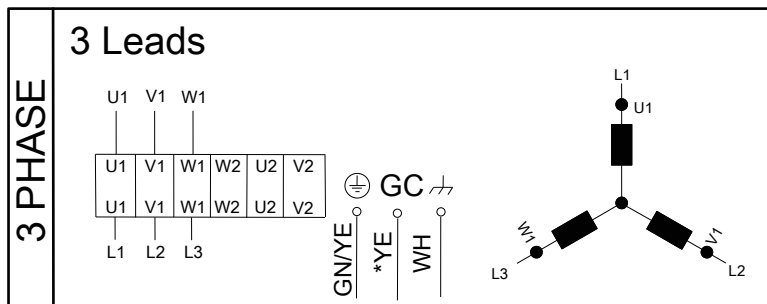

WS009162B

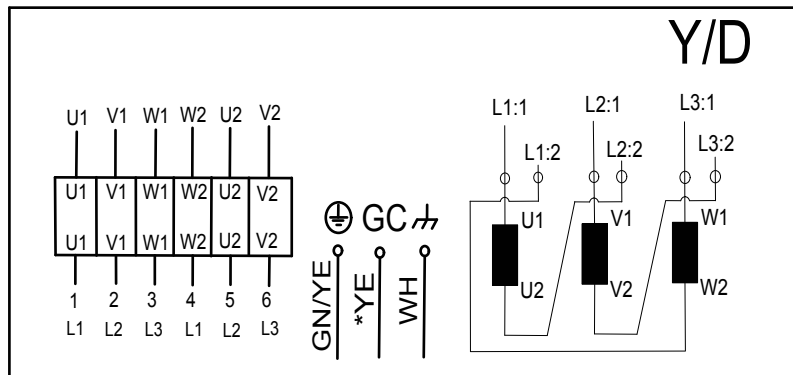
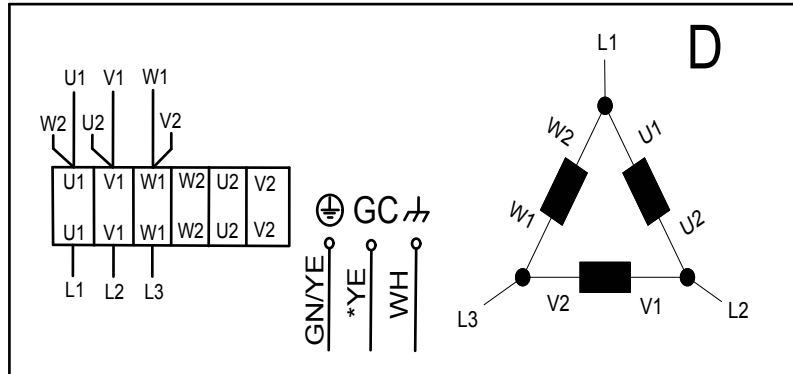
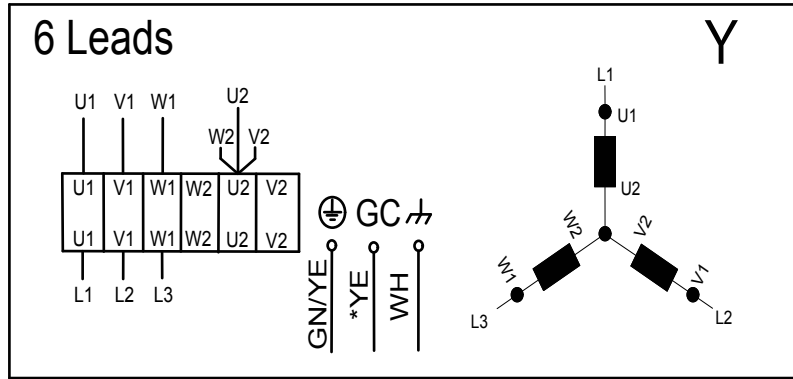

WS004126B

WS004127B

EN

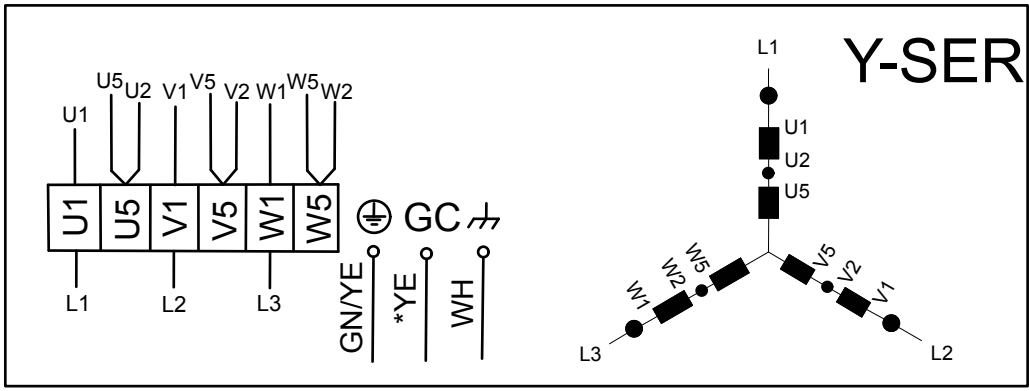
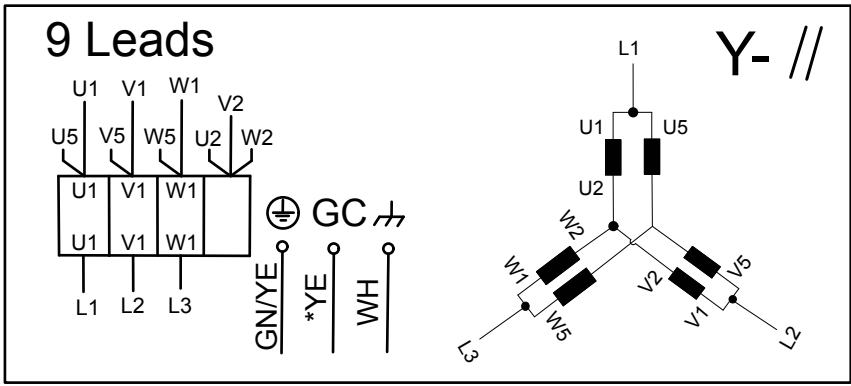

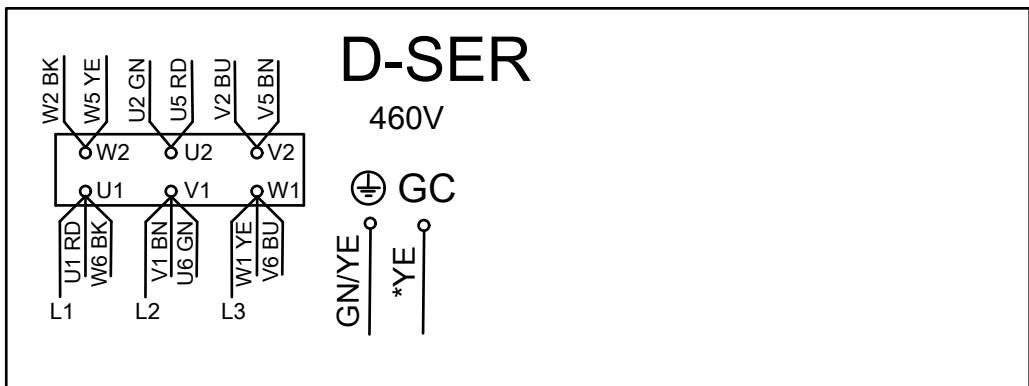
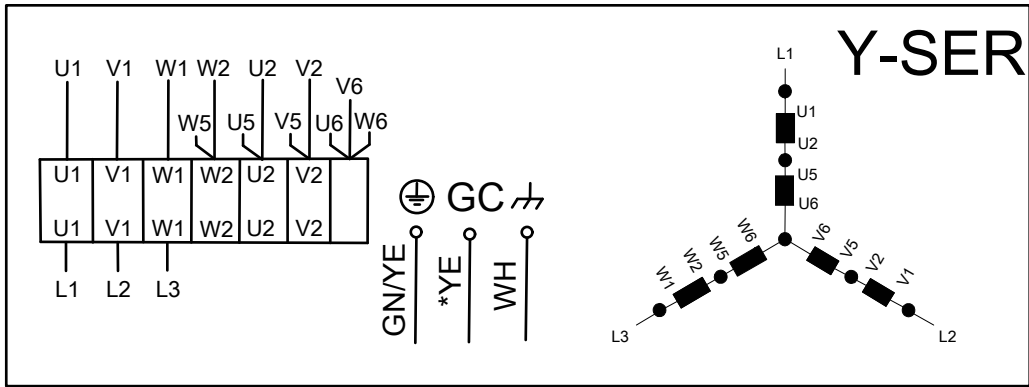
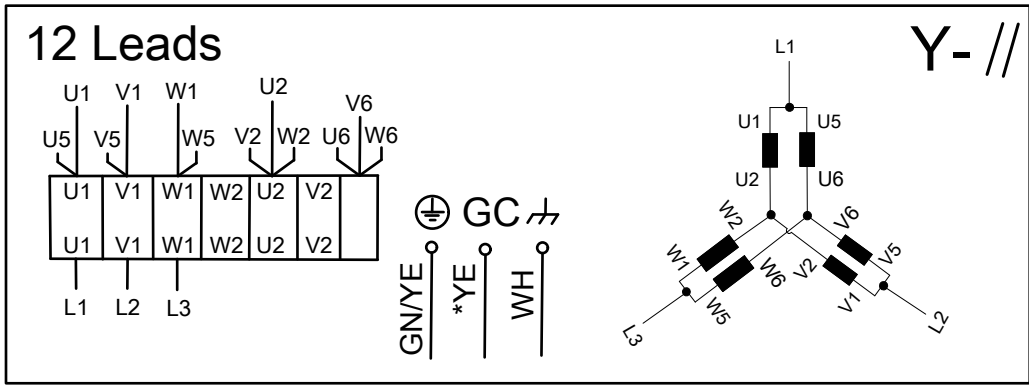

WS004128C

4.2.6.4 1-phase connection

EN

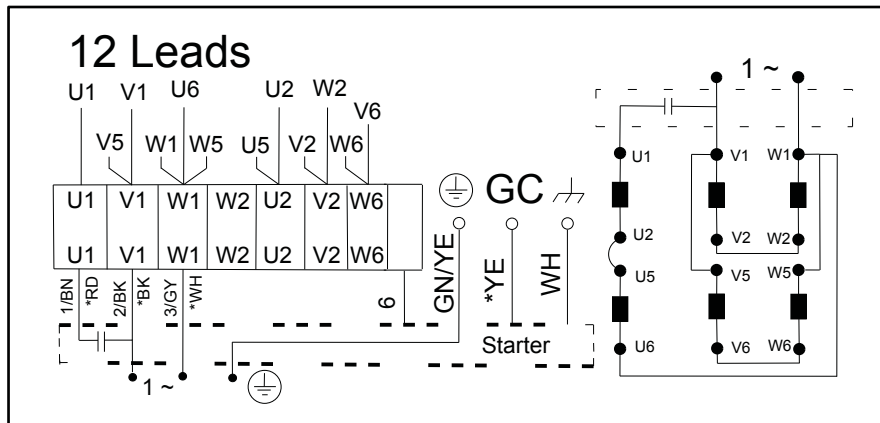
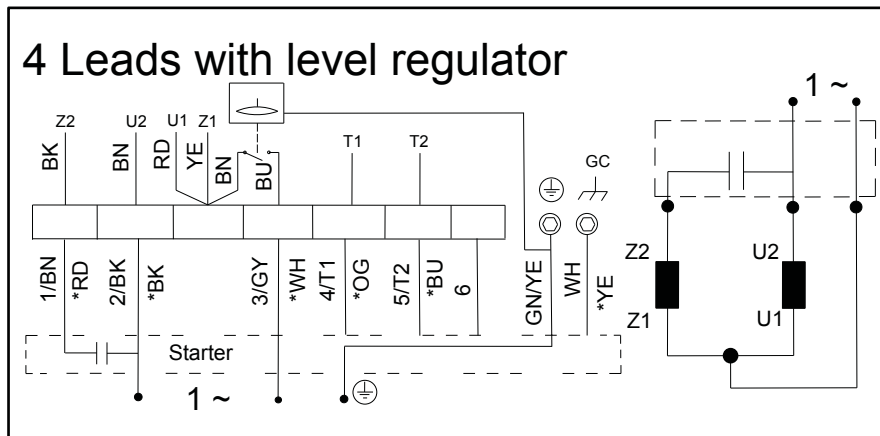
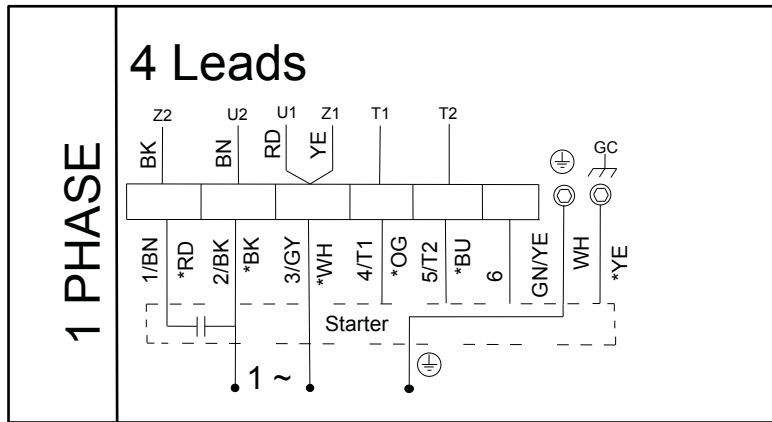
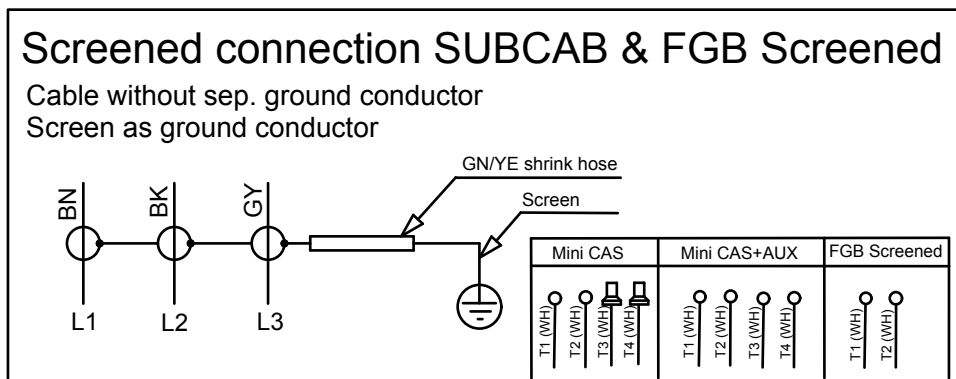

Figure 8: Without built-in starter

For more information, see [Colors and markings of leads](#) on page 28.

WS004129C

4.2.6.5 Screened cable connection



WS004132B

EN

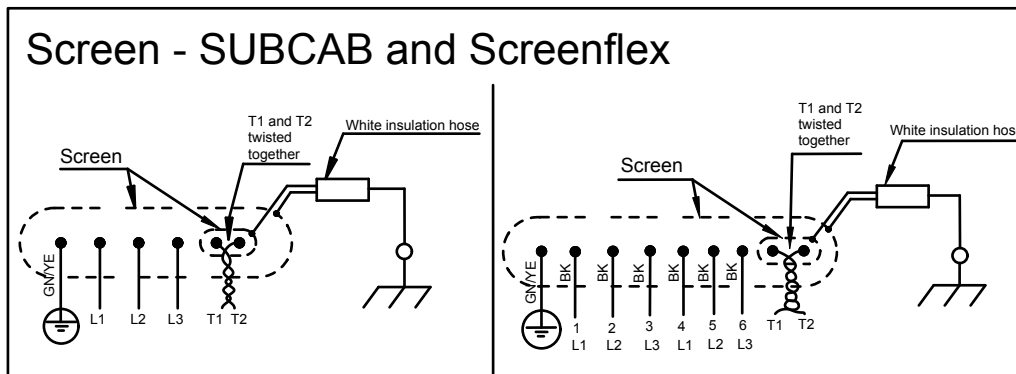

Sensors connection

Not all charts are applicable for every product.

These sensor connections are applicable for 3-phase and 1-phase without built-in starter:

SENSORS	Control	SUBCAB 7GX & 4GX Screenflex	SUBCAB AWG	SUBCAB screened
	T1	WH T1	OG	WH T1
	T2	WH T2	BU	WH T2
	T3	-	-	WH T3
	T4	-	-	WH T4

*If Y/D-start, sensors not connected

WS004130D

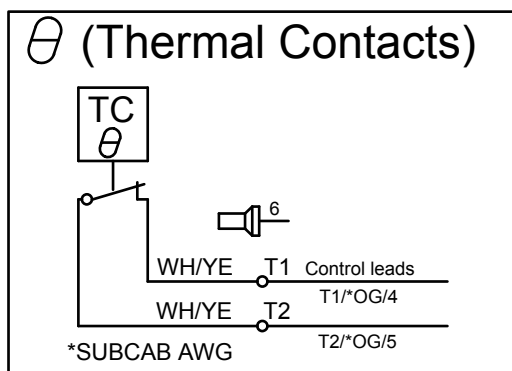

WS011184C

EN

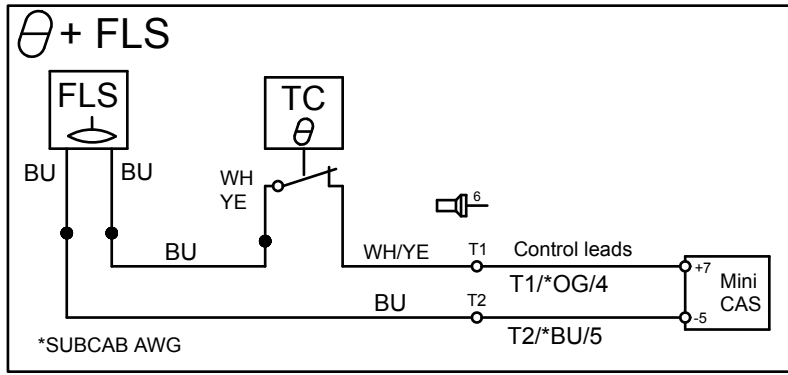

WS01185B

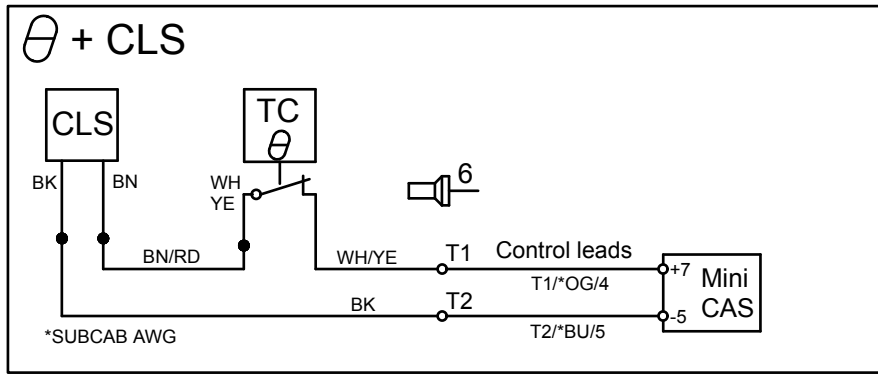

WS01186B

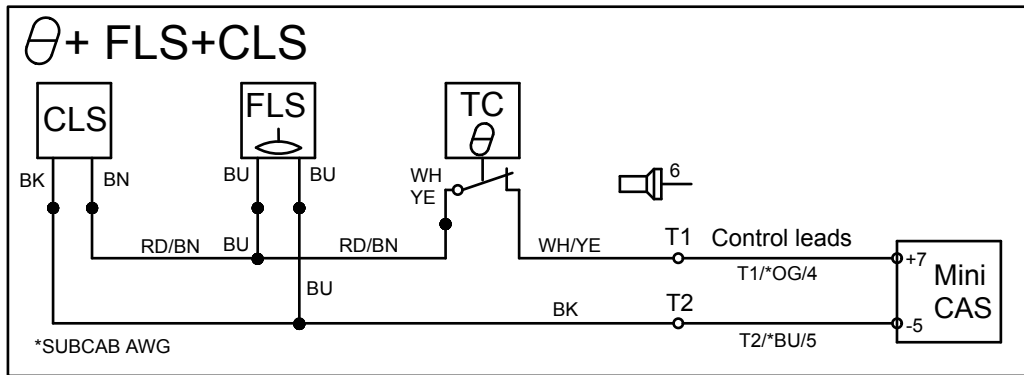

WS01187B

Hot water execution

For non Ex-pumps: Temp > 40° T1,T2 thermal contacts not connected

WS004131D

4.2.6.6 Sensor connection characteristics

The values have a 10% tolerance.

Sensors	Value (mA)	Definition
FLS and thermal contact	0	Overtemperature
	7.8	OK
	36	Leakage

4.3 Check the impeller rotation

**CAUTION: Crush Hazard**

The starting jerk can be powerful. Make sure nobody is close to the unit when it is started.

EN

1. Start the motor.
2. Stop the motor after a few seconds.
3. Check that the impeller rotates according to this illustration.

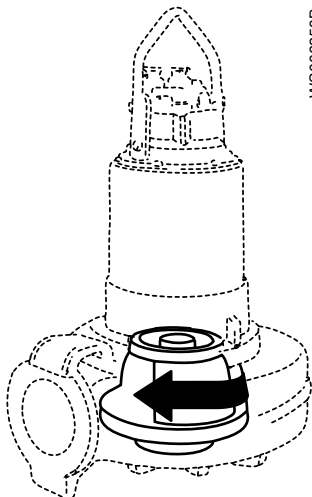

The correct direction of impeller rotation is clockwise when you look at the pump from above.

4. If the impeller rotates in the wrong direction, then do one of these steps:
 - If the motor has a 1-phase connection, then contact a sales or authorized service representative.
 - If the motor has a 3-phase connection, then transpose two phase leads and do this procedure again.

5 Operation

5.1 Precautions

Before taking the unit into operation, check the following:

- All recommended safety devices are installed.
- The cable and cable entry have not been damaged.
- All debris and waste material has been removed.

NOTICE:

Never operate the pump with the discharge line blocked, or the discharge valve closed.



WARNING: Crush Hazard

Risk of automatic restart.

Distance to wet areas



WARNING: Electrical Hazard

Risk of electrical shock or burn. You must connect an additional ground- (earth-) fault protection device to the grounded (earthed) connectors if persons are likely to come into contact with liquids that are also in contact with the pump or pumped liquid.



CAUTION: Electrical Hazard

Risk of electrical shock or burn. The equipment manufacturer has not evaluated this unit for use in swimming pools. If used in connection with swimming pools then special safety regulations apply.

Noise level

NOTICE:

The sound power level of the product is lower than 70 dB(A). However, in some installations the resulting sound pressure level may exceed 70 dB(A) at certain operating points on the performance curve. Make sure that you understand the noise level requirements in the environment where the product is installed. Failure to do so may result in hearing loss or violation of local laws.

5.2 Estimate zinc anode replacement intervals

The mass and surface area of the zinc anodes are designed to protect the pump surface for 1 year in sea water with an average temperature of 20°C (68°F). Shorter inspection intervals and anode replacement can be required, depending upon the water temperature and the chemical composition as well as the presence of other metals in the vicinity of the pump.

The rate of zinc consumption, and the appropriate inspection intervals, can be estimated by measuring how much zinc is consumed during the first two months following installation.

Anodes are replaced when the anode mass is reduced to a selected fraction of its initial mass. The recommended interval for the selection fraction is 0.25–0.50 (25–50%).

1. Remove, weigh, and reinstall one or more of the exterior zinc anodes before starting up the pump.
2. After two months, remove and weigh the same zinc anode or anodes again.
3. Divide the lapsed time in days (between steps 1 and 2) by the anode weight loss in grams to get the calculated anode consumption rate (days/gram).

If multiple anodes were weighed, then use the anode which has lost the most weight for this calculation.

4. Calculate future replacement intervals so that they occur when the selected fraction of zinc is remaining.

5.3 Start the pump

EN



CAUTION: Crush Hazard

The starting jerk can be powerful. Make sure nobody is close to the unit when it is started.



CAUTION: Thermal Hazard

The surfaces or parts of the unit may become hot during operation. Allow surfaces to cool before starting work, or wear heat-protective clothing.

NOTICE:

Make sure that the rotation of the impeller is correct. For more information, see Check the impeller rotation.

1. Check the oil level in the oil housing.
2. Remove the fuses or open the circuit breaker, and check that the impeller can rotate freely.



WARNING: Crush Hazard

Never put your hand into the pump housing.

3. Conduct insulation test phase to ground. To pass, the value must exceed 5 megaohms.
4. Check that the monitoring equipment works.
5. Start the pump.

6 Maintenance

6.1 Precautions



Before starting work, make sure that the safety instructions have been read and understood.

DANGER: Crush Hazard

Moving parts can entangle or crush. Always disconnect and lock out power before servicing to prevent unexpected startup. Failure to do so could result in death or serious injury.



DANGER: Inhalation Hazard

Before entering the work area, make sure that the atmosphere contains sufficient oxygen and no toxic gases.



WARNING: Biological Hazard

Infection risk. Rinse the unit thoroughly with clean water before working on it.



CAUTION: Crush Hazard

Make sure that the unit cannot roll or fall over and injure people or damage property.

Make sure that you follow these requirements:

- Check the explosion risk before you weld or use electrical hand tools.
- Allow all system and pump components to cool before you handle them.
- Make sure that the product and its components have been thoroughly cleaned.
- Before starting work, make sure that the work area is well-ventilated.
- Do not open any vent or drain valves or remove any plugs while the system is pressurized. Make sure that the pump is isolated from the system and that pressure is relieved before you disassemble the pump, remove plugs, or disconnect piping.

Ground continuity verification

A ground (earth) continuity test must always be performed after service.

6.2 Maintenance guidelines

During the maintenance and before reassembly, always remember to perform these tasks:

- Clean all parts thoroughly, particularly O-ring grooves.
- Change all O-rings, gaskets, and seal washers.
- Lubricate all springs, screws, O-rings with grease.

During the reassembly, always make sure that existing index markings are in line.

The reassembled drive unit must always be insulation-tested and the reassembled pump must always be test-run before normal operation.

6.3 Torque values

All screws and nuts must be lubricated to achieve correct tightening torque. Screws that are screwed into stainless steel must have the threads coated with applicable lubricants to prevent seizing.

If there is a question regarding the tightening torques, then contact a sales or authorized service representative.

EN

Screws and nuts

Table 1: Stainless steel, A2 and A4, torque Nm (lbf-ft)

Property class	M4	M5	M6	M8	M10	M12	M16	M20	M24	M30
50	1.0 (0.74)	2.0 (1.5)	3.0 (2.2)	8.0 (5.9)	15 (11)	27 (20)	65 (48)	127 (93.7)	220 (162)	434 (320)
70, 80	2.7 (2)	5.4 (4)	9.0 (6.6)	22 (16)	44 (32)	76 (56)	187 (138)	364 (268)	629 (464)	1240 (915)
100	4.1 (3)	8.1 (6)	14 (10)	34 (25)	66 (49)	115 (84.8)	248 (183)	481 (355)	—	—

Table 2: Steel, torque Nm (lbf-ft)

Property class	M4	M5	M6	M8	M10	M12	M16	M20	M24	M30
8.8	2.9 (2.1)	5.7 (4.2)	9.8 (7.2)	24 (18)	47 (35)	81 (60)	194 (143)	385 (285)	665 (490)	1310 (966.2)
10.9	4.0 (2.9)	8.1 (6)	14 (10)	33 (24)	65 (48)	114 (84)	277 (204)	541 (399)	935 (689)	1840 (1357)
12.9	4.9 (3.6)	9.7 (7.2)	17 (13)	40 (30)	79 (58)	136 (100)	333 (245)	649 (480)	1120 (825.1)	2210 (1630)

Table 3: Brass, torque Nm (lbf-ft)

M5	M8	M10
2.7 (2.0)	11 (8.1)	22 (16.2)

Hexagon screws with countersunk heads

For hexagon socket head screws with countersunk head, maximum torque for all property classes must be 80% of the values for property class 8.8.

Round nuts with set screws

Table 4: Set screw, torque Nm (lbf-ft)

The torque values are only valid for the set screw, and not for the round nut.

M8	M10
18 (13)	35 (26)

6.4 Change the oil

This image shows the plug that is used to change the oil.

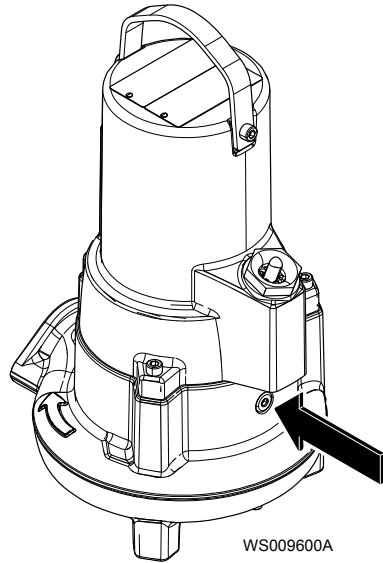

Empty the oil



CAUTION: Compressed Gas Hazard

Air inside the chamber may cause parts or liquid to be propelled with force. Be careful when opening. Allow the chamber to de-pressurize before removal of the plug.

1. Put the pump in a horizontal position and unscrew the oil plug.

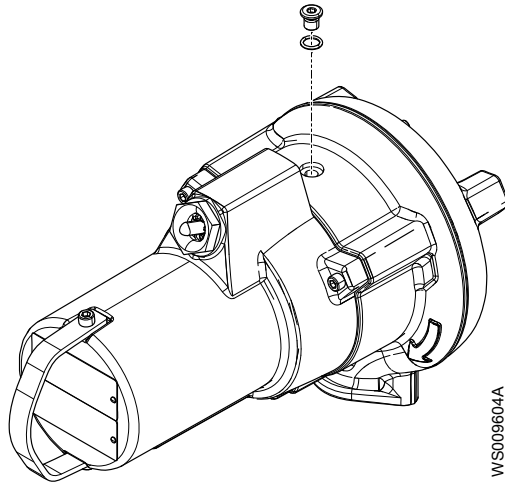

2. Put a container under the pump and turn the pump.

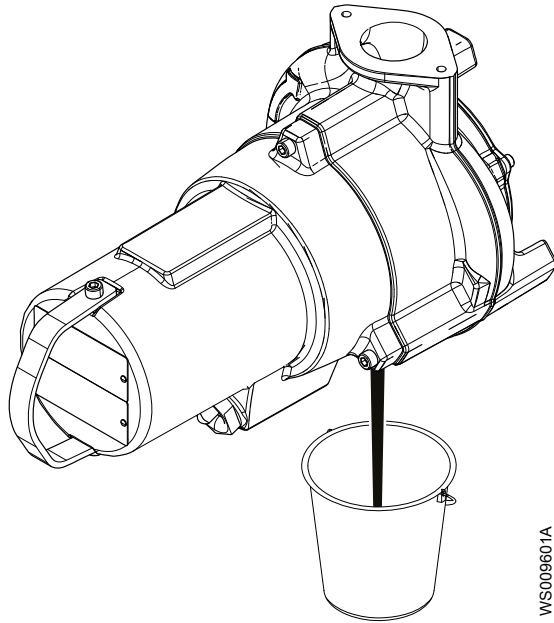

Fill with oil

The oil should be a medical white oil of paraffin type that fulfills FDA 172.878 (a) and viscosity close to VG32. Examples of applicable oil types are the following:

- Statoil MedicWay 32™
- BP Enerpar M 004™
- Shell Ondina 927™
- Shell Ondina X430™

1. Replace the O-ring of the oil plug.
2. Fill with oil.

Pump	Pressure class	Hydraulic type	Size	Oil volume, L (gal)
3069.060/160/760	SH	N	DN 50/65	0.6 (0.16)
3069.060/160/760	MT	N	DN 80	0.5 (0.13)
3069.070/190/770	SH	N	DN 50/65	0.5 (0.13)
3069.070/190/770	MT	N	DN 80	0.4 (0.1)
3069.170	HT	M	DN 40/50	0.6 (0.16)
3069.890	HT	M	DN 40/50	0.5 (0.13)
3069.180	HT	D	DN 50	0.6 (0.16)
3069.180	MT	D	DN 65	0.5 (0.13)
3069.180	LT	D	DN 65/80	0.5 (0.13)
3069.180	LT	F	DN 40	0.5 (0.13)
3069.180	MT	D-ARV*	DN 50	0.5 (0.13)
3069.090	HT	D	DN 50	0.5 (0.13)
3069.090	MT	D	DN 65	0.4 (0.1)
3069.090	LT	D	DN 65/80	0.4 (0.1)
3069.090	LT	F	DN 40	0.4 (0.1)
3069.090	MT	D-ARV*	DN 50	0.4 (0.1)

*Abrasion-resistant version

EN

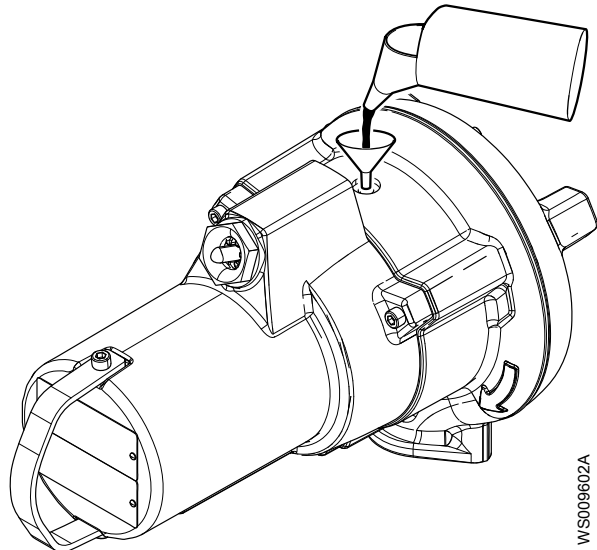

- 3. Refit and tighten the oil plug.
Tightening torque: 10–40 Nm (7.5–29.5 lbf-ft).

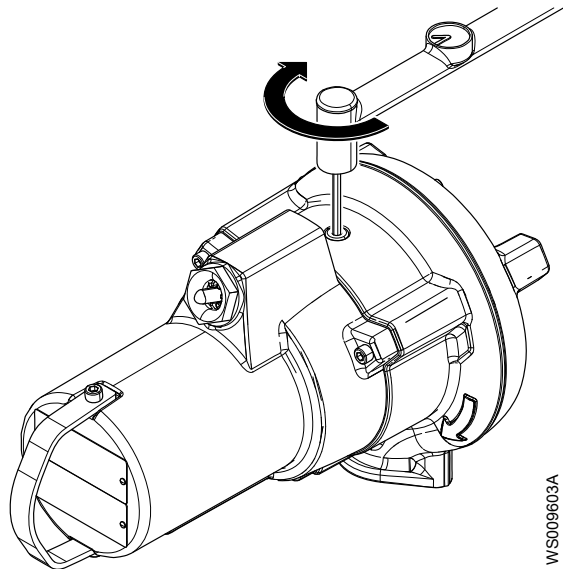

6.5 Service the pump

Type of maintenance	Purpose	Inspection interval
Initial inspection	A Xylem-authorized personnel checks the pump condition. From the results, the personnel recommends the intervals for the periodical inspection and overhaul for the installation.	Within the first year of operation.
Periodical inspection	The inspection prevents operational interruptions and machine breakdowns. The measures to increase performance and pump efficiency are decided for each application. They can include such things as impeller trimming, wear part control and replacement, control of zinc-anodes and control of the stator.	Up to every year Applies to normal applications and operating conditions at media (liquid) temperatures <40°C (104°F).

Type of maintenance	Purpose	Inspection interval
Overhaul	The overhaul lengthens the operating lifetime of the product. It includes the replacement of key components and the measures that are taken during an inspection.	Up to every three years Applies to normal applications and operating conditions at media (liquid) temperatures <40°C (104°F).

NOTICE:

Shorter intervals may be required when the operating conditions are extreme, for example with very abrasive or corrosive applications or when the liquid temperatures exceed 40°C (104°F).

6.5.1 Inspection

Service item	Action
Cable	<ol style="list-style-type: none"> 1. If the outer jacket is damaged, then replace the cable. 2. Check that the cables do not have any sharp bends and are not pinched.
Connection to power	Check that the connections are properly secured.
Electrical cabinets	Check that they are clean and dry.
Impeller	<ol style="list-style-type: none"> 1. Check the clearance. 2. If necessary, adjust.
Stator housing	<ol style="list-style-type: none"> 1. Drain any liquid. 2. Check the resistance of the leakage sensor. Normal value approximately 1500 ohms, alarm approximately 430 ohms.
Insulation	<p>Use a megger maximum 1000 V.</p> <ol style="list-style-type: none"> 1. Check that the resistance between the ground (earth) and phase lead is more than 5 megohms. 2. Conduct a phase-to-phase resistance check.
Junction box	Check that it is clean and dry.
Lifting device	Check that the local safety regulations are followed.
Lifting handle	<ol style="list-style-type: none"> 1. Check the screws. 2. Check the condition of the lifting handle and the chain. 3. If necessary, replace.
O-rings	<ol style="list-style-type: none"> 1. Replace the O-rings of the oil plugs. 2. Replace the O-rings at the entrance or junction cover. 3. Lubricate the new O-rings.
Overload protection and other protections	Check the correct settings.
Personnel safety devices	Check the guard rails, covers, and other protections.
Rotation direction	Check the impeller rotation.
Oil housing	If necessary, fill with new oil.
Electrical connections	Check that the connections are properly secured.
Thermal contacts	Normally closed circuit; interval 0–1 ohm.
Voltage and amperage	Check the running values.

6.5.2 Overhaul

The basic repair kit includes O-rings, seals, and bearings.

For an overhaul, do the following in addition to the tasks listed under Inspection.

Service item	Action
Support and main bearing	Replace the bearings with new bearings.
Mechanical seal	Replace with new seal units.

6.5.3 Service in case of alarm

For information about indication values for sensors, see [Sensors connection](#) on page 33.

Alarm source	Action
FLS	<ol style="list-style-type: none"> 1. Check for liquid in the stator housing. 2. Drain all liquid, if any. 3. Check the mechanical seal unit, the O-rings, and the cable entry, if liquid was found.
Thermal contact	Check the start and stop levels.
The overload protection	Check that the impeller can rotate freely.

6.6 Replace the D-impeller

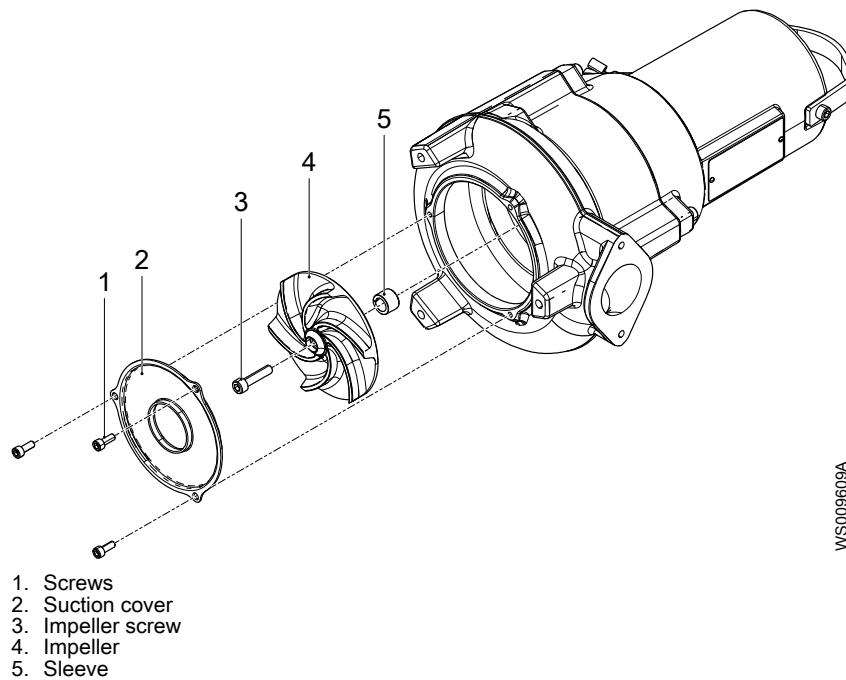

Figure 9: Standard variant

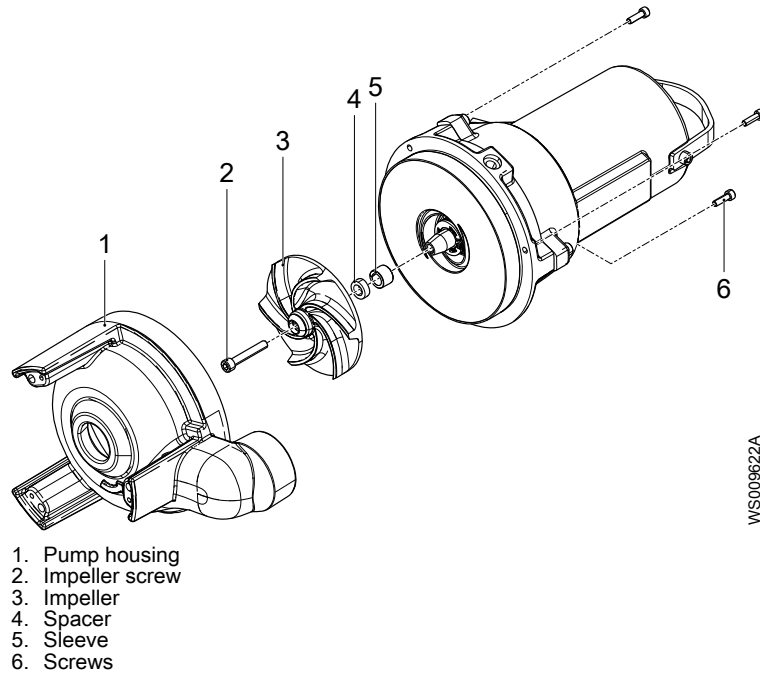

Figure 10: Abrasive resistant variant

6.6.1 Remove the D-impeller



CAUTION: Cutting Hazard

Worn parts can have sharp edges. Wear protective clothing.

1. Uncover the impeller:
 - For the standard variant, remove the screws and the suction cover.
 - For the abrasive resistant variant, remove the screws and the pump housing.
2. Remove the impeller screw.
Prevent the impeller from rotating.
3. Remove the impeller:
 - For the standard variant, remove the impeller and the sleeve.
 - For the abrasive resistant variant, remove the impeller, the spacer, and the sleeve.

6.6.2 Install the D-impeller

1. Prepare the shaft:
 - a) Polish off any flaws by using a fine emery cloth.
The end of the shaft must be clean and free from burrs.
 - b) Coat the inner conic and the outer cylindrical surfaces of the sleeve with a thin layer of grease.

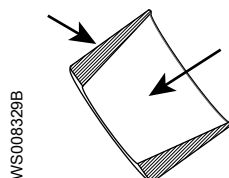

The correct lubrication is grease for bearings, for example Exxon Mobil Unirex N3, Mobil Mobilith SHC 220 or equivalent.

NOTICE:

Surplus grease can cause the impeller to become loose. Remove surplus grease from conical and/or cylindrical surfaces of shafts and/or sleeves.

2. Prepare the impeller:
 - For the standard variant, insert the sleeve into the impeller.
 - For the abrasive resistant variant, insert the spacer and the sleeve into the impeller.

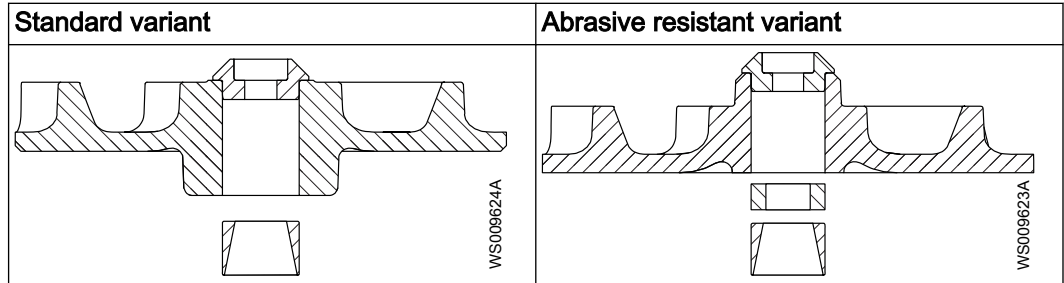

3. Mount the impeller:
 - a) Lubricate the threads of the impeller screw.
Always use a new screw.
 - b) Fit the impeller to the shaft.
 - c) Fit the impeller screw to the shaft.
 - d) Tighten the impeller screw.
Prevent the impeller from rotating.
For tightening torque, see [Torque values](#) on page 39.
4. Cover the impeller:
 - For the standard variant, install the suction cover and tighten the screws.
 - For the abrasive resistant variant, install the pump housing. Tighten the screws.

6.7 Replace the F-impeller

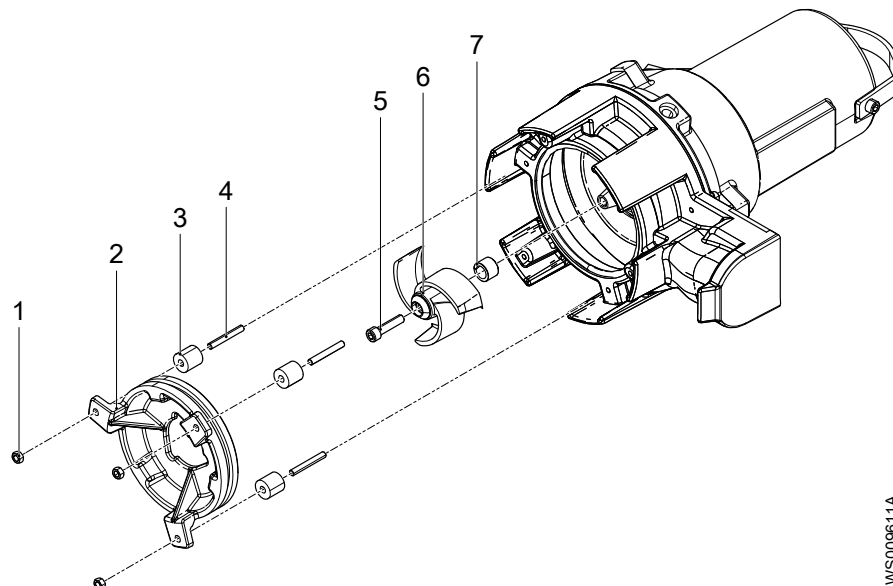

1. Nuts
2. Suction cover
3. Seal sleeves
4. Studs
5. Impeller screw
6. Impeller
7. Sleeve

6.7.1 Remove the F-impeller



CAUTION: Cutting Hazard

Worn parts can have sharp edges. Wear protective clothing.

1. Remove the nuts, the suction cover, and the seal sleeves.
2. Remove the impeller screw.
Prevent the impeller from rotating.
3. Remove the impeller and the sleeve.

6.7.2 Install the F-impeller

1. Prepare the shaft:
 - a) Polish off any flaws by using a fine emery cloth.
The end of the shaft must be clean and free from burrs.
 - b) Coat the inner conic and the outer cylindrical surfaces of the sleeve with a thin layer of grease.

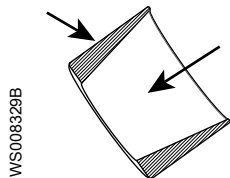

The correct lubrication is grease for bearings, for example Exxon Mobil Unirex N3, Mobil Mobilith SHC 220 or equivalent.

NOTICE:

Surplus grease can cause the impeller to become loose. Remove surplus grease from conical and/or cylindrical surfaces of shafts and/or sleeves.

2. Mount the impeller:
 - a) Insert the sleeve into the impeller.
 - b) Lubricate the threads of the impeller screw.
Always use a new screw.
 - c) Fit the impeller to the shaft.
 - d) Fit the impeller screw to the shaft.
 - e) Tighten the impeller screw.
Prevent the impeller from rotating.
For tightening torque, see *Torque values* on page 39.
3. Install the suction cover:
 - a) Fit the studs on the pump housing.
Use Loctite 603 locking liquid to secure the studs.

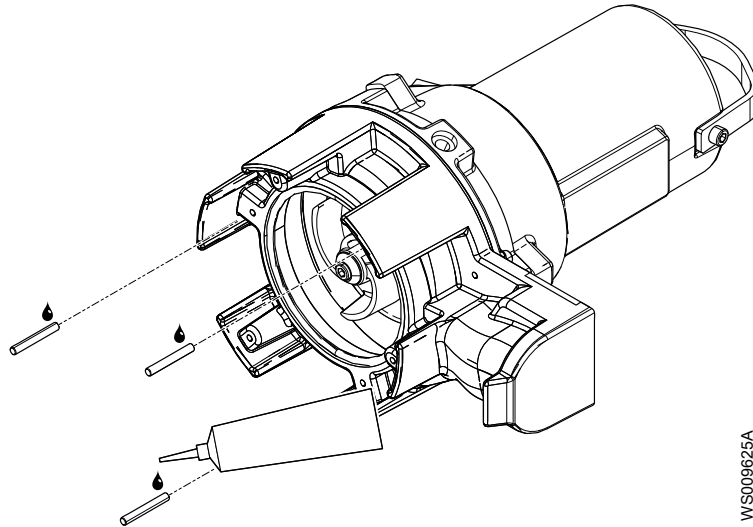

- b) Fit the seal sleeves, the suction cover, and the nuts on the studs.
 - c) Tighten the nuts gradually until the suction cover touches the impeller.
Alternate between the nuts in a circular pattern.
4. Adjust the suction cover:
- a) Raise the pump to an upright position.
 - b) Check that the impeller can rotate freely.
If necessary, then loosen the nuts.
 - c) Measure the clearance.
Final clearance: 0.2–0.8 mm (0.008–0.03 in)

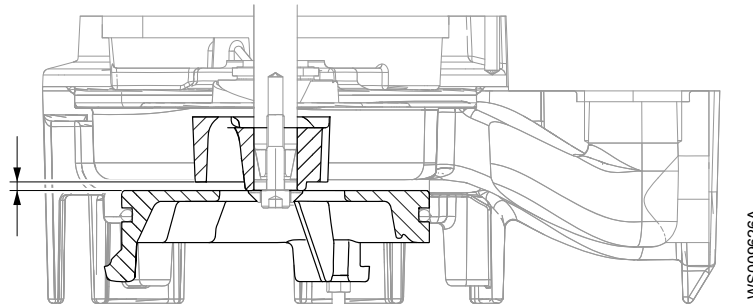

6.8 Replace the M-impeller and the cutting wheel

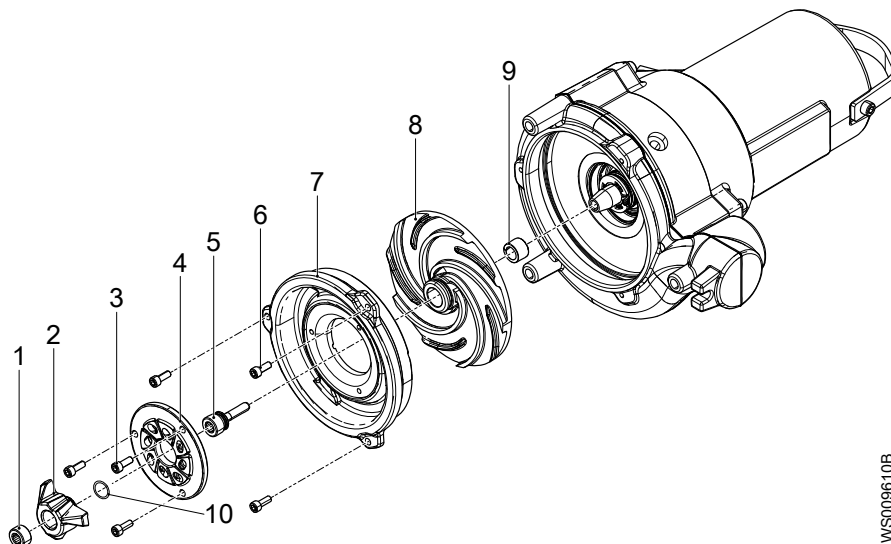

1. Set screw
2. Cutting wheel
3. Screws
4. Cutting ring
5. Adjustment screw
6. Screws
7. Suction cover
8. Impeller
9. Sleeve
10. Adjustment washer, plastic shim

6.8.1 Remove the cutting wheel



DANGER: Crush Hazard

Moving parts can entangle or crush. Always disconnect and lock out power before servicing to prevent unexpected startup. Failure to do so could result in death or serious injury.



CAUTION: Cutting Hazard

Worn parts can have sharp edges. Wear protective clothing.

-
1. Prevent the cutting wheel from rotating, and remove the set screw.
 2. Prevent the adjustment screw from rotating, and remove the cutting wheel from the adjustment screw.

6.8.2 Remove the M-impeller

1. Remove the screws and the cutting ring.
2. Remove the screws and the suction cover.
3. Remove the adjustment screw.
4. Remove the impeller and the sleeve.

6.8.3 Install the M-impeller

1. Prepare the shaft:
 - a) Polish off any flaws by using a fine emery cloth.
The end of the shaft must be clean and free from burrs.
 - b) Coat the inner conic and the outer cylindrical surfaces of the sleeve with a thin layer of grease.

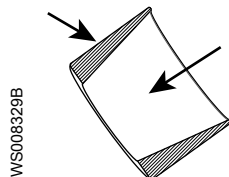

The correct lubrication is grease for bearings, for example Exxon Mobil Unirex N3, Mobil Mobilith SHC 220 or equivalent.

NOTICE:

Surplus grease can cause the impeller to become loose. Remove surplus grease from conical and/or cylindrical surfaces of shafts and/or sleeves.

-
2. Mount the impeller:
 - a) Insert the sleeve into the impeller.
 - b) Fit the impeller to the shaft.
 - c) Coat the cylindrical surface of the pump housing with a thin layer of grease.

The correct lubrication is grease for bearings, for example Exxon Mobil Unirex N3, Mobil Mobilith SHC 220 or equivalent.

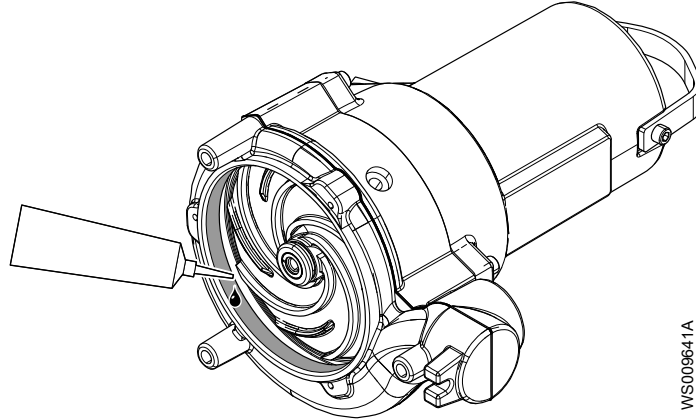

- d) Fit the suction cover and tighten the screws.
- e) Lubricate both threads of the adjustment screw.
Always use a new screw.
- f) Fit the adjustment screw into the shaft.
Do not tighten the screw.
- g) Adjust the impeller towards the suction cover until the parts touch.
Use a screwdriver or similar in the groove of the impeller.

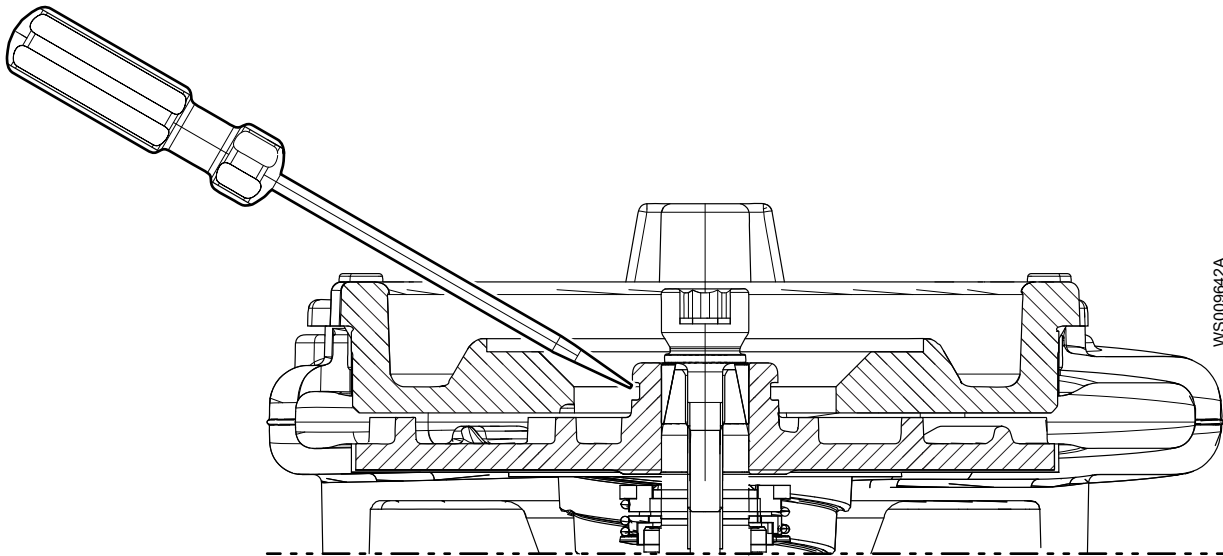

- h) Tighten the adjustment screw.
Prevent the impeller from rotating.
Tightening torque: 22 Nm (16 lbf-ft)
 - i) Tighten the screw a further 1/8 turn (45°).
 - j) Check that the impeller can rotate freely.
3. Measure the clearance.
Final clearance: 0.1–0.5 mm (0.004–0.02 in)

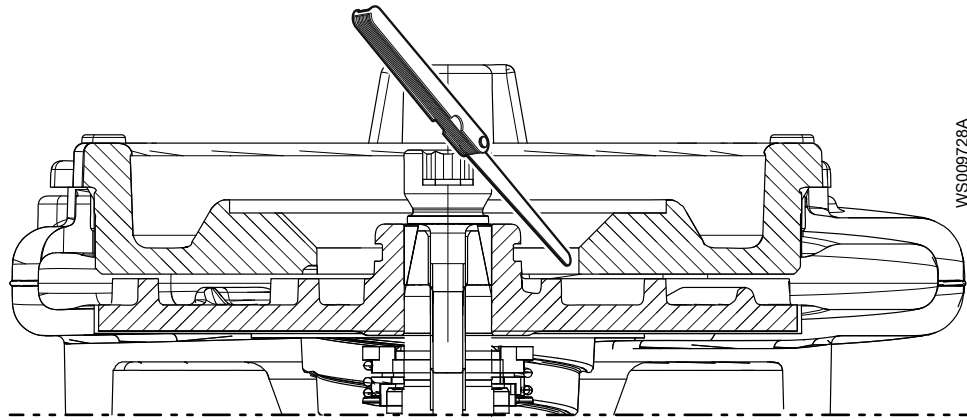

4. Fit the cutting ring and tighten the screws.

6.8.4 Install the cutting wheel

1. Fit the plastic shim between the cutting ring and the cutting wheel.
The 0.19 mm (0.007 in) thick plastic shim is a spare part: Adjustment washer 811 62 50.
2. Fit the cutting wheel to the adjustment screw until the wheel touches the plastic shim.
3. Fit and tighten the set screw.
Tightening torque: 55 Nm (41 lbf·ft)
4. Make sure that the impeller and cutting wheel can rotate freely.
5. If the cutting wheel does not rotate freely, then adjust it:
 - a) Prevent the cutting wheel from rotating, and loosen the set screw.
 - b) To increase the clearance, prevent the adjustment screw from rotating and turn the cutting wheel counterclockwise.
 - c) Make sure that the impeller and cutting wheel can rotate freely.
 - d) Measure the distance between the cutting wheel and the cutting ring.
Measure for every wing on the cutting wheel. The distance must be less than 0.25 mm (0.010 in) for at least one of the wings.
 - e) When the clearance is correct, tighten the set screw.
Tightening torque: 55 Nm (41 lbf·ft)

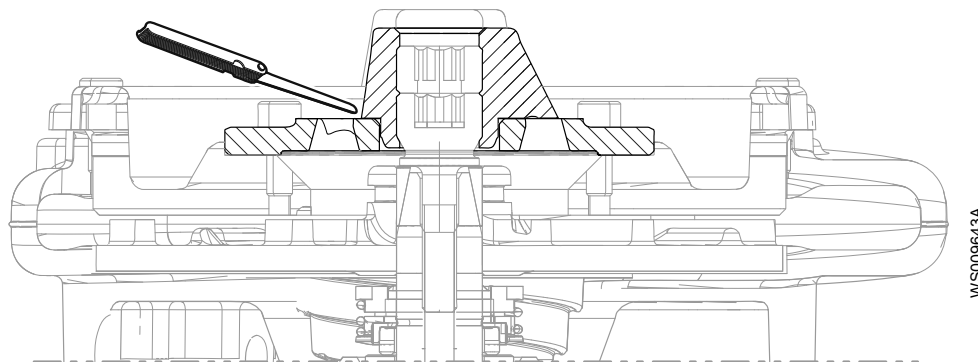

6.9 Replace the N-impeller



CAUTION: Cutting Hazard

Worn parts can have sharp edges. Wear protective clothing.

NOTICE:

When laying the pump on its side, do not allow the weight of the pump to rest on any portion of the impeller. The impeller must not be allowed to make contact with the concrete floor or other hard and rough surfaces.

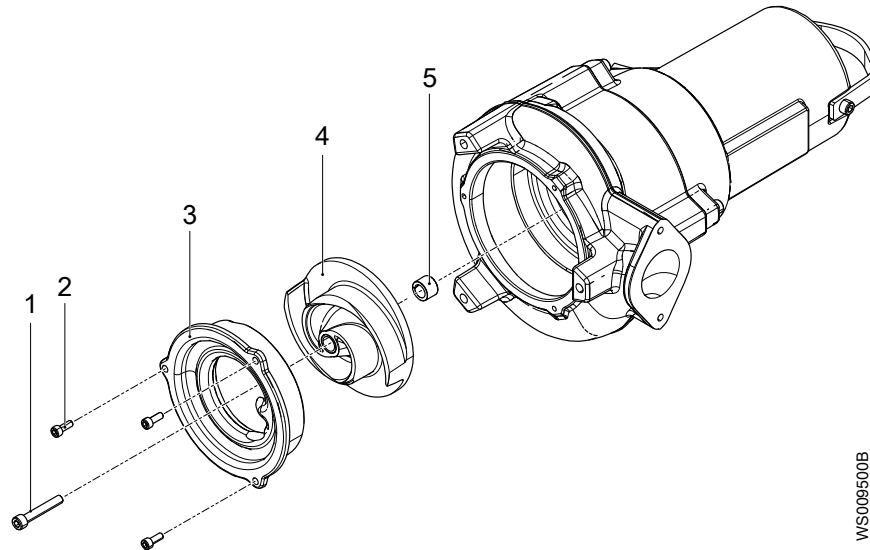

1. Impeller screw
2. Screws
3. Suction cover
4. Impeller
5. Sleeve

WS009500B

6.9.1 Remove the N-impeller

1. Loosen the impeller screw.

Prevent the impeller from rotating. Insert a screwdriver or similar through the pump housing inlet.

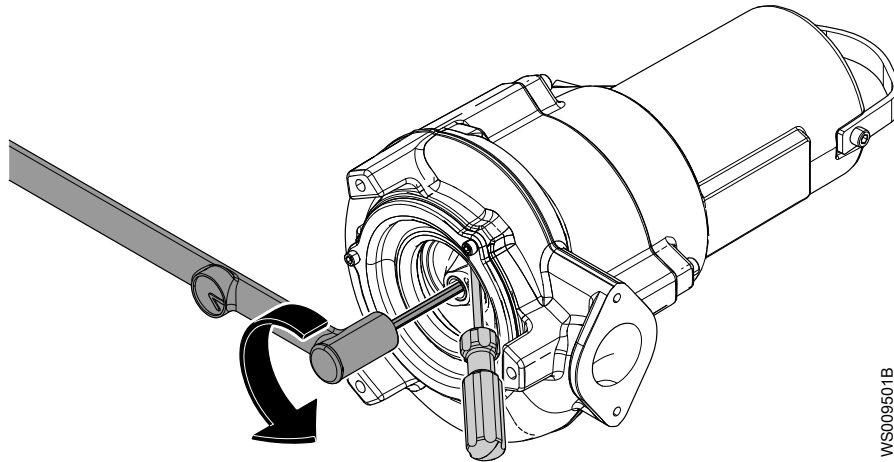

WS009501B

2. Remove and discard the impeller screw.
3. Insert a hexagon wrench and turn the adjustment screw clockwise until the impeller comes loose from the shaft and the adjustment screw is free from the threaded hole.

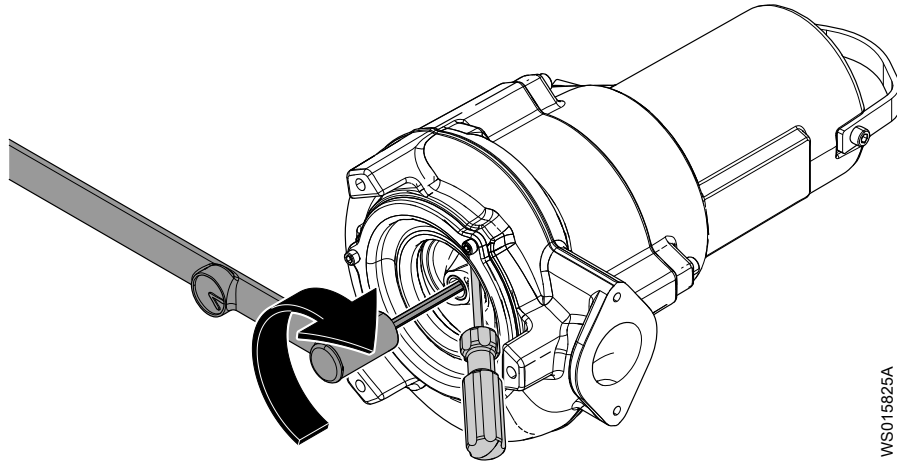

WS015825A

4. Remove the suction cover.
If necessary, then pry off the suction cover.
5. Remove the impeller, the adjustment screw, and the conical sleeve.

6.9.2 Install the N-impeller

1. Before installation of the impeller, push the sleeve to check that it moves freely up and down.
When the sleeve is released, it must be fully pushed out again. If the sleeve does not move freely, or does not come fully out, then replace the impeller unit.

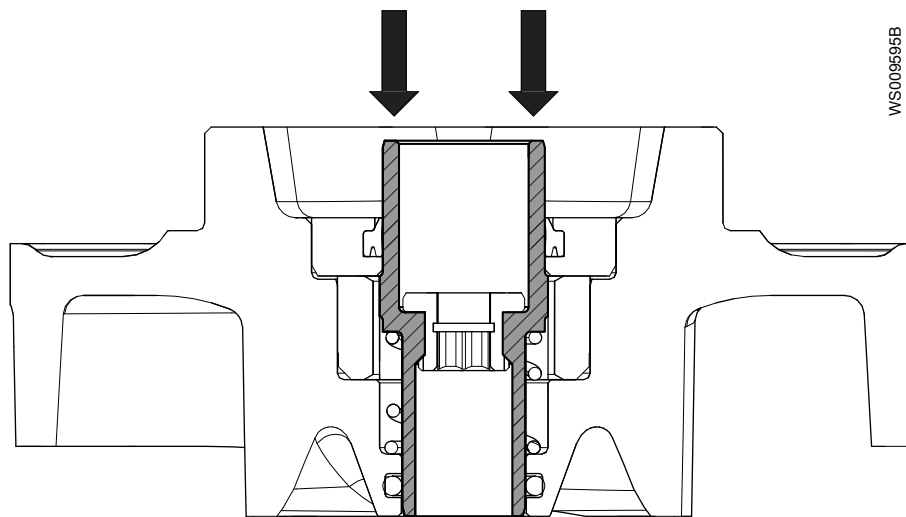

WS009595B

2. Adjust the adjustment screw in the new impeller.
The correct position is at the bottom without any tightening.

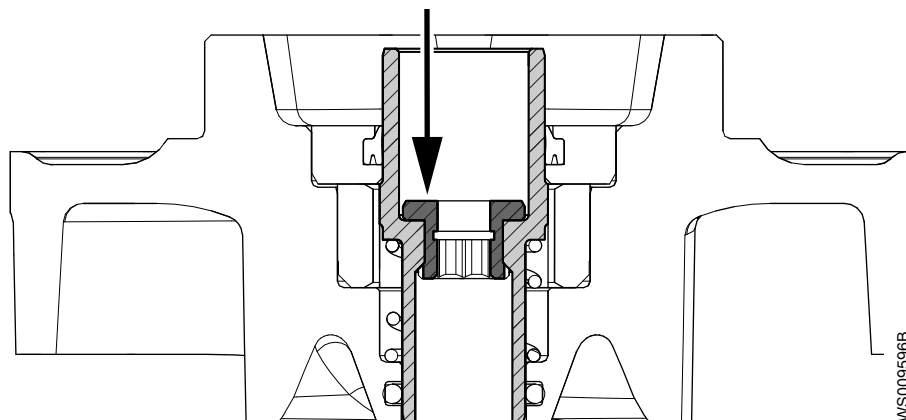

WS009596B

3. Prepare the shaft:

- a) Polish off any flaws by using a fine emery cloth.
The end of the shaft must be clean and free from burrs.
- b) Coat the inner conic and the outer cylindrical surfaces of the sleeve with a thin layer of grease.

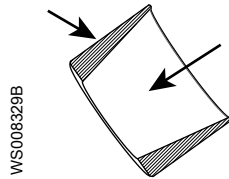

The correct lubrication is grease for bearings, for example Exxon Mobil Unirex N3, Mobil Mobilith SHC 220 or equivalent.

NOTICE:

Surplus grease can cause the impeller to become loose. Remove surplus grease from conical and/or cylindrical surfaces of shafts and/or sleeves.

4. Install the impeller sleeve and the impeller onto the shaft.

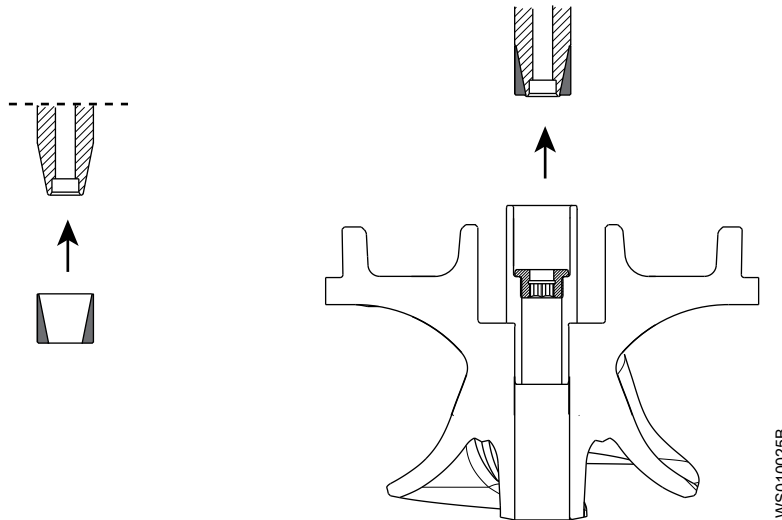

5. Fit the suction cover and tighten the screws.

Point the guide pin towards the outlet.

For tightening torque, see [Torque values](#) on page 39.

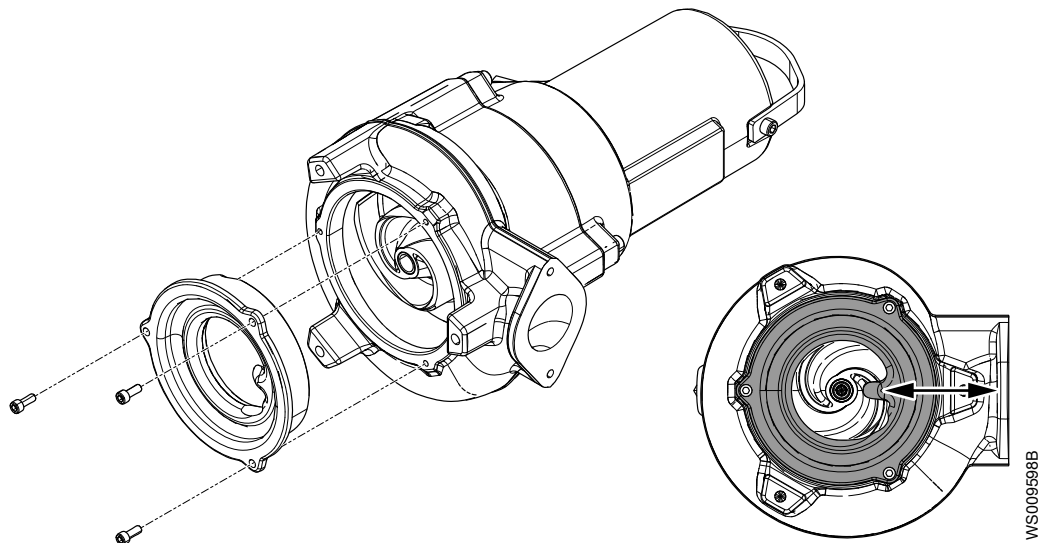

6. Check that the impeller can rotate freely.



WARNING: Crush Hazard

Beware of the pinch point hazard between the rotating impeller and the guide pin.

7. Adjust the impeller:

- a) Prevent the impeller from rotating. Insert a screwdriver or similar through the pump housing inlet.
- b) Turn the adjustment screw clockwise until the impeller barely touches the suction cover.

The screw must not be overtightened.

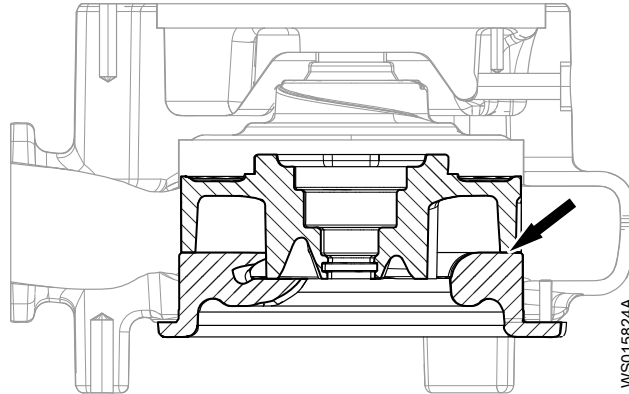

8. Attach the impeller:

- a) Lubricate the threads of the impeller screw.
Always use a new screw.
- b) Fit the lubricated impeller screw.
- c) Tighten the impeller screw.

For tightening torque, see [Torque values](#) on page 39.

Prevent the impeller from rotating. Insert a screwdriver or similar through the pump housing inlet.

- d) Tighten the screw a further 1/8 turn (45°).
- e) Check that the impeller can rotate freely.

The impeller must not touch the insert ring.



WARNING: Crush Hazard

Beware of the pinch point hazard between the rotating impeller and the guide pin.

- f) Check that the impeller moves freely up and down by pushing it.

When the sleeve is released, it should be fully pushed out again. If the sleeve does not move freely, or does not come fully out, then replace the impeller unit.

9. Check with a feeler gauge that the impeller clearance is 0.1–0.6 mm (0.004–0.02 in).

EN

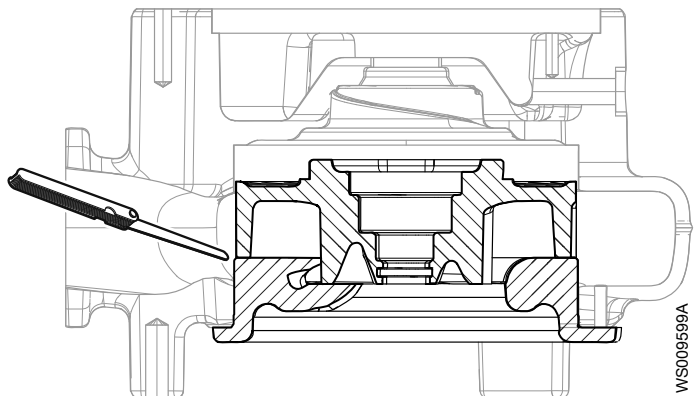

7 Troubleshooting

7.1 Electrical troubleshooting

EN



DANGER: Electrical Hazard

Troubleshooting a live control panel exposes personnel to hazardous voltages. Electrical troubleshooting must be done by a qualified electrician.

Follow these guidelines when troubleshooting:

- Disconnect and lock out the power supply except when conducting checks that require voltage.
- Make sure that no one is near the unit when the power supply is reconnected.
- When troubleshooting electrical equipment, use the following:
 - Universal instrument multimeter
 - Test lamp (continuity tester)
 - Wiring diagram

7.2 The pump does not start



DANGER: Crush Hazard

Moving parts can entangle or crush. Always disconnect and lock out power before servicing to prevent unexpected startup. Failure to do so could result in death or serious injury.



NOTICE:

Do NOT override the motor protection repeatedly if it has tripped. Doing so may result in equipment damage.

Cause	Remedy
An alarm signal has been triggered on the control panel.	Check that: <ul style="list-style-type: none"> • The impeller rotates freely. • The sensor indicators do not indicate an alarm. • The overload protection is not tripped.
The pump does not start automatically, but can be started manually.	Check that: <ul style="list-style-type: none"> • The start level regulator is functioning. Clean or replace if necessary. • All connections are intact. • The relay and contactor coils are intact. • The control switch (Man/Auto) makes contact in both positions. Check the control circuit and functions.

Cause	Remedy
The installation is not receiving voltage.	Check that: <ul style="list-style-type: none"> • The main power switch is on. • There is control voltage to the start equipment. • The fuses are intact. • There is voltage in all phases of the supply line. • All fuses have power and that they are securely fastened to the fuse holders. • The overload protection is not tripped. • The motor cable is not damaged.
The impeller is stuck.	Clean: <ul style="list-style-type: none"> • The impeller • The sump in order to prevent the impeller from clogging again.

If the problem persists, then contact a sales or authorized service representative.

Always state the serial number of the product, see [Product Description](#) on page 12.

7.3 The pump does not stop when a level sensor is used



DANGER: Crush Hazard

Moving parts can entangle or crush. Always disconnect and lock out power before servicing to prevent unexpected startup. Failure to do so could result in death or serious injury.



Cause	Remedy
The pump is unable to empty the sump to the stop level.	Check that: <ul style="list-style-type: none"> • There are no leaks from the piping and/or discharge connection. • The impeller is not clogged. • The non-return valve(s) are functioning properly. • The pump has adequate capacity. For information: Contact a sales or authorized service representative.
There is a malfunction in the level-sensing equipment.	<ul style="list-style-type: none"> • Clean the level regulators. • Check the functioning of the level regulators. • Check the contactor and the control circuit. • Replace all defective items.
The stop level is set too low.	Raise the stop level.

If the problem persists, then contact a sales or authorized service representative.

Always state the serial number of the product, see [Product Description](#) on page 12.

7.4 The pump starts-stops-starts in rapid sequence

Cause	Remedy
The pump starts due to back-flow which fills the sump to the start level again.	Check that: <ul style="list-style-type: none"> • The distance between the start and stop levels is sufficient. • The non-return valve(s) work(s) properly. • The length of the discharge pipe between the pump and the first non-return valve is sufficiently short.

Cause	Remedy
The self-holding function of the contactor malfunctions.	Check: <ul style="list-style-type: none"> • The contactor connections. • The voltage in the control circuit in relation to the rated voltages on the coil. • The functioning of the stop-level regulator. • Whether the voltage drop in the line at the starting surge causes the contactor's self-holding malfunction.

If the problem persists, then contact a sales or authorized service representative.

Always state the serial number of the product, see [Product Description](#) on page 12.

7.5 The pump runs but the motor protection trips



DANGER: Crush Hazard

Moving parts can entangle or crush. Always disconnect and lock out power before servicing to prevent unexpected startup. Failure to do so could result in death or serious injury.



NOTICE:

Do NOT override the motor protection repeatedly if it has tripped. Doing so may result in equipment damage.

Cause	Remedy
The motor protection is set too low.	Set the motor protection according to the data plate and if applicable the cable chart.
The impeller is difficult to rotate by hand.	<ul style="list-style-type: none"> • Clean the impeller. • Clean out the wet well. • Check that the impeller is correctly trimmed.
The drive unit cannot receive full voltage on all three phases.	<ul style="list-style-type: none"> • Check the fuses. Replace fuses that have tripped. • If the fuses are intact, then notify a certified electrician.
The phase currents change, or they are too high.	Contact a sales or authorized service representative.
The insulation between the phases and ground in the stator is defective.	<ol style="list-style-type: none"> 1. Use an insulation tester. Use a 1000 VDC insulation and continuity tester to check that the insulation between the phases, and between any phase and ground, is > 5 megohms. 2. If the insulation is less, then do the following: Contact a sales or authorized service representative.
The density of the pumped fluid is too high.	Make sure that the maximum density is 1100 kg/m ³ (9.2 lb/US gal) <ul style="list-style-type: none"> • Change to a more applicable pump • Contact a sales or authorized service representative.
There is a malfunction in the overload protection.	Replace the overload protection.

If the problem persists, then contact a sales or authorized service representative.

Always state the serial number of the product, see [Product Description](#) on page 12.

7.6 The pump delivers too little or no water



DANGER: Crush Hazard

Moving parts can entangle or crush. Always disconnect and lock out power before servicing to prevent unexpected startup. Failure to do so could result in death or serious injury.



NOTICE:

Do NOT override the motor protection repeatedly if it has tripped. Doing so may result in equipment damage.

Cause	Remedy
The impeller rotates in the wrong direction.	<ul style="list-style-type: none"> If it is a 3-phase pump, then transpose two phase leads. If it is a 1-phase pump, then do the following: Contact a sales or authorized service representative.
One or more of the valves are set in the wrong positions.	<ul style="list-style-type: none"> Reset the valves that are set in the wrong position. Replace the valves, if necessary. Check that all valves are correctly installed according to media flow. Check that all valves open correctly.
The impeller is difficult to rotate by hand.	<ul style="list-style-type: none"> Clean the impeller. Clean out the sump. Check that the impeller is properly trimmed.
The pipes are obstructed.	To ensure a free flow, clean out the pipes.
The pipes and joints leak.	Find the leaks and seal them.
There are signs of wear on the impeller, pump, and casing.	Replace the worn parts.
The liquid level is too low.	<ul style="list-style-type: none"> Check that the level sensor is set correctly. Depending on the installation type, add a means for priming the pump, such as a foot valve.

If the problem persists, then contact a sales or authorized service representative. Always state the serial number of the product, see [Product Description](#) on page 12.

8 Technical Reference

8.1 Motor data

EN

Feature	Description
Motor type	Squirrel-cage induction
Frequency	50 Hz or 60 Hz
Supply	1-phase or 3-phase
Starting method	<ul style="list-style-type: none"> • Direct on-line • Star-delta • Soft starter • Variable frequency drive (VFD) For more information, see VFD requirements on page 23.
Maximum starts for each hour	15 evenly spaced starts for each hour
Code compliance	IEC 60034-1
Voltage variation without overheating	±10%, if it does not run continuously at full load
Voltage imbalance tolerance	2%
Stator insulation class	F (155°C [311°F])

Motor encapsulation

Motor encapsulation is in accordance with IP68.

8.1.1 Thermal contacts, opening temperature

The table shows the opening temperature for the thermal contacts on products approved for hazardous locations.

Temperature and temperature class	Motor				
	3-phase			1-phase	
125°C (257°F), T4	13-08-2BB	13-08-4BB	13-10-2BB	13-10-2BB	13-10-4BB
140°C (284°F), T3	13-10-4BB				

8.2 Application limits

Data	Description
Liquid temperature	Maximum 40°C (104°F) The pump is intended to operate completely submerged in the pumped liquid. Warm-liquid version: 70°C (158°F) maximum
Liquid density	1100 kg/m ³ (9.2 lb for each US gal) maximum
pH of the pumped media	5.5–14
Depth of immersion	Maximum 20 m (65 ft)
Other	For the specific weight, current, voltage, power ratings, and speed of the pump, see the data plate of the pump.

8.3 Minimum permitted liquid level

In hazardous areas, this information is critical for the safety of the installation of this product. The pump must completely submerged in the pumped liquid during operation.

EN

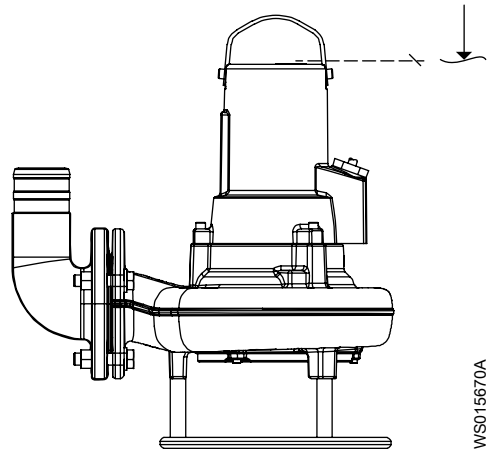

WS015670A

Xylem |'zīləm|

- 1) The tissue in plants that brings water upward from the roots;
- 2) a leading global water technology company.

We're a global team unified in a common purpose: creating advanced technology solutions to the world's water challenges. Developing new technologies that will improve the way water is used, conserved, and re-used in the future is central to our work. Our products and services move, treat, analyze, monitor and return water to the environment, in public utility, industrial, residential and commercial building services settings. Xylem also provides a leading portfolio of smart metering, network technologies and advanced analytics solutions for water, electric and gas utilities. In more than 150 countries, we have strong, long-standing relationships with customers who know us for our powerful combination of leading product brands and applications expertise with a strong focus on developing comprehensive, sustainable solutions.

For more information on how Xylem can help you, go to www.xylem.com



Xylem Water Solutions Global
Services AB 556782-9253
361 80 Emmaboda
Sweden
Tel: +46-471-24 70 00
Fax: +46-471-24 74 01
<https://tpi.xylem.com>

Visit our Web site for the latest version of this document and more information
The original instruction is in English. All non-English instructions are translations of the original instruction.
© 2016 Xylem Inc.
Flygt is a trademark of Xylem Inc. or one of its subsidiaries. All other trademarks or registered trademarks are property of their respective owners.